

CATHOLIC HIGH SCHOOL
PRELIMINARY EXAMINATION (2024)
PRIMARY SIX
SCIENCE
BOOKLET A

Name: _____ ()

Class: Primary 6 - _____

Date: 22 August 2024

28 questions

56 marks

Total Time for Booklets A and B: 1 hour 45 minutes

INSTRUCTIONS TO CANDIDATES

Do not turn over this page until you are told to do so.

Follow all instructions carefully.

Answer all questions.

Shade your answers in the Optical Answer Sheet (OAS) provided.

This booklet consists of 18 printed pages, excluding the cover page.

Booklet A (28 × 2 marks)

For each question from 1 to 28, four options are given. One of them is the correct answer. Make your choice (1, 2, 3 or 4). Shade your answer on the Optical Answer Sheet. **(56 marks)**

1 Which characteristic **cannot** be used to identify a bird from a mammal?

- (1) how it moves
- (2) how it obtains air
- (3) type of body covering
- (4) method of reproduction

2 Study the diagram.

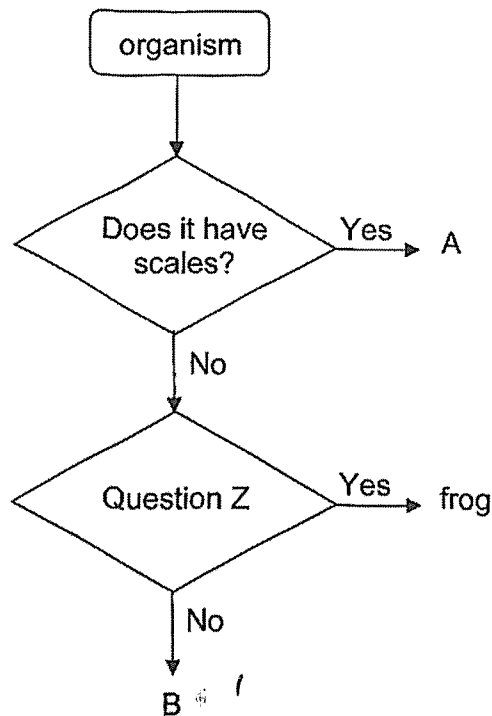



Which of the following best represents A, B and Z?

	Question Z	A	B
(1)	Does it breathe with gills?	fish	cow
(2)	Does it lay eggs?	crocodile	chicken
(3)	Does it swim?	whale	butterfly
(4)	Does it live both on land and in water?	snake	bear

3 Study the table.

Function	Parts of the human digestive system		
	A	B	C
digestion takes place	✓		✓
digestion is completed			✓
removes water from undigested food		✓	

Which of the following correctly matches the functions to the parts of the system?

		
(1)	A	C
(2)	A	B
(3)	C	B
(4)	C	A

4 The diagram shows the female reproductive system of a human.

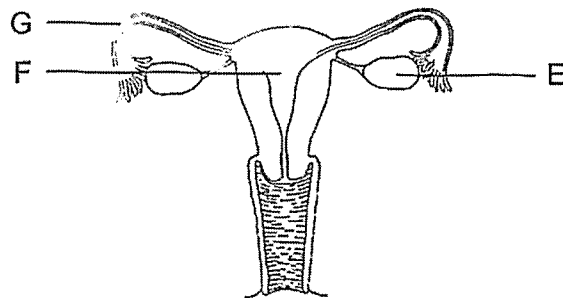

Which of the following is correct?

	Eggs are produced at	Fertilised egg develops at
(1)	F	G
(2)	G	E
(3)	E	F
(4)	F	E

5 The diagram shows the direction of blood flow in some parts of the body.

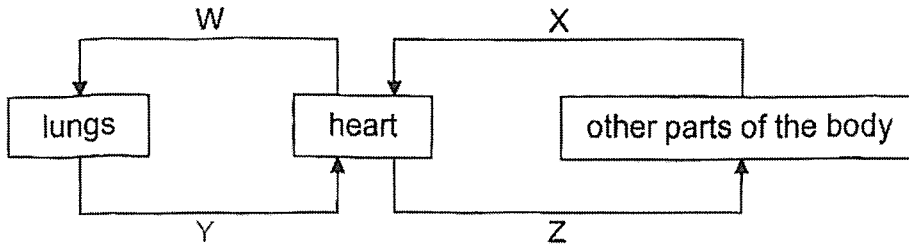

The same amount of blood was taken from W, X, Y and Z.

Which graph shows the correct comparison of the amount of oxygen in the blood samples?

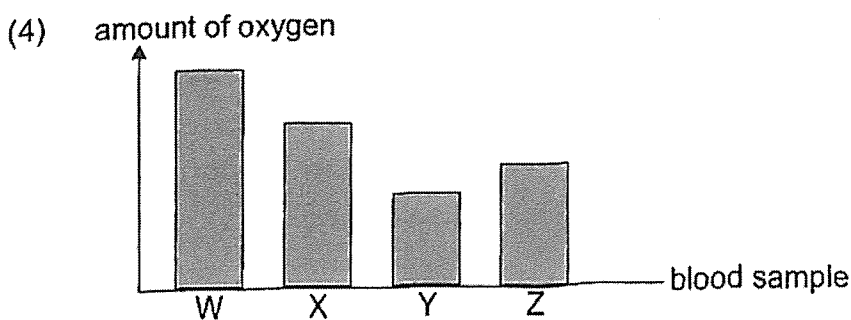
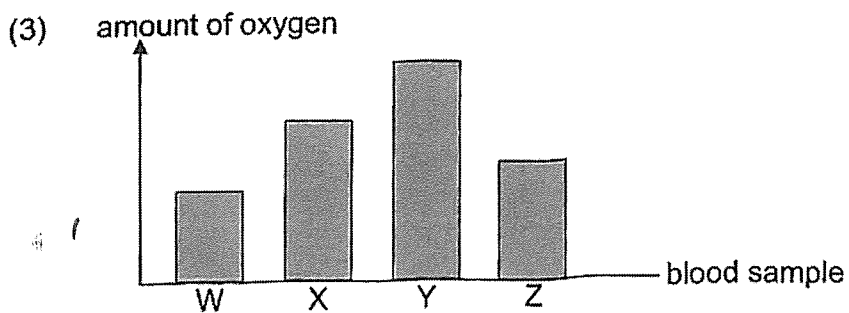
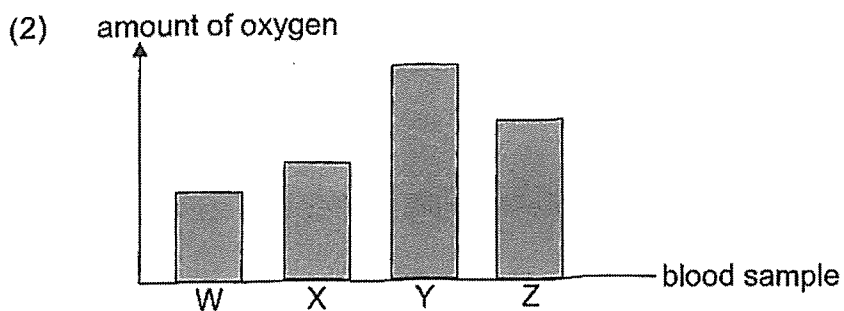
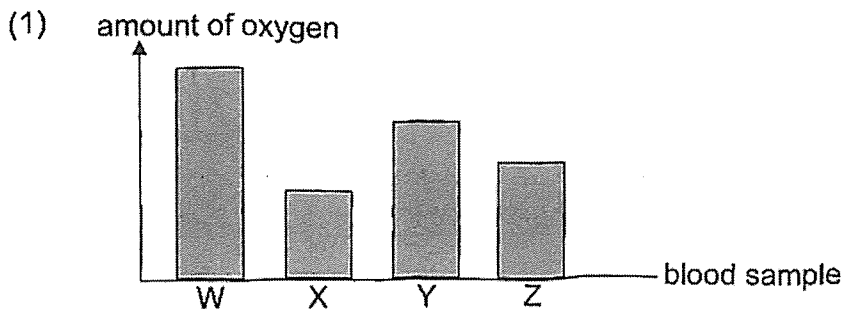

6 Study the diagram.

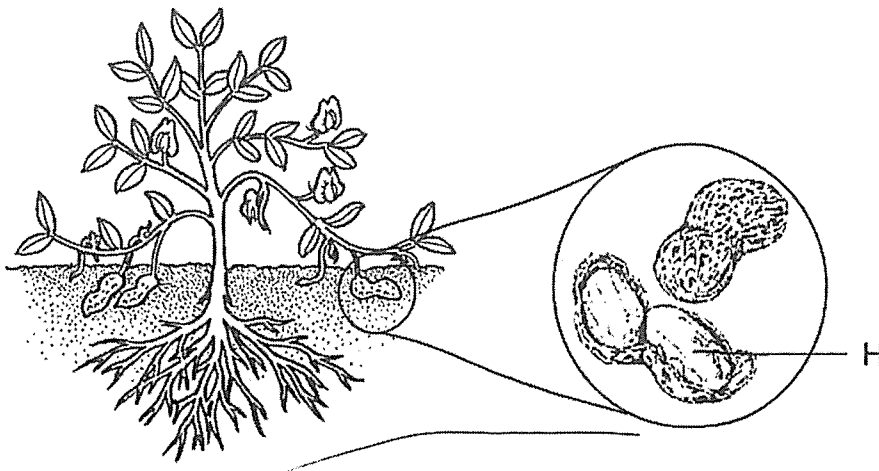

Why is part H important to the plant?

- A It can develop into a new plant.
- B It anchors the plant firmly to the ground.
- C It stores excess food made by the plant.
- D It absorbs water and mineral salts for the plant.

- (1) A and C only
- (2) B and D only
- (3) A, B and C only
- (4) B, C and D only

7 Which statement(s) about a spore and an ovule is/are correct?

- A Both are dispersed by wind.
- B Both will grow into a young plant.
- C Both are required for reproduction.
- D Both are produced by flowering plants. X

- (1) C only
- (2) A and B only
- (3) ~~A~~ and D only
- (4) B, C and D only X

- 8 Eugene wrote the hypothesis, "substance Y increases the rate of water uptake by a plant". He carried out an investigation using one of the set-ups, P, Q, R and S, to check if his hypothesis was correct. Similar stalks of roses and the same amount of water were used for each container.

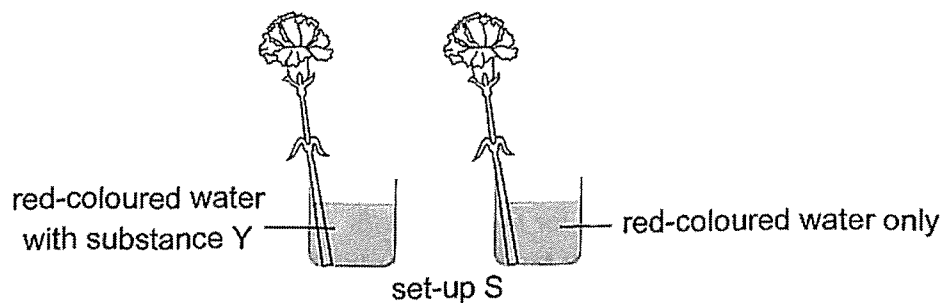
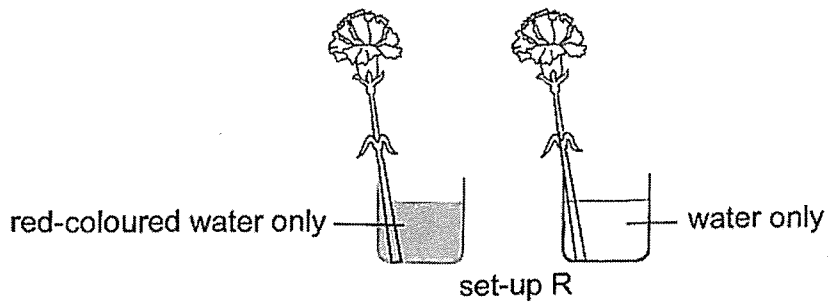
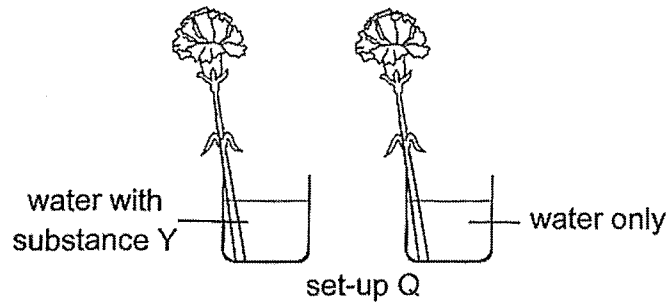
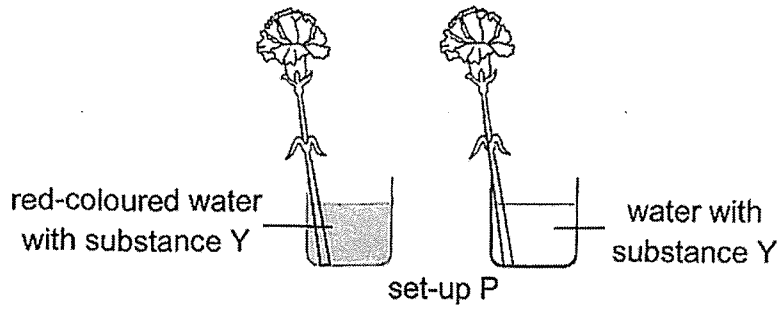

Which set-up should Eugene use to check if his hypothesis was correct?

- (1) P
- (2) Q
- (3) R
- (4) S

9 Study the diagram.

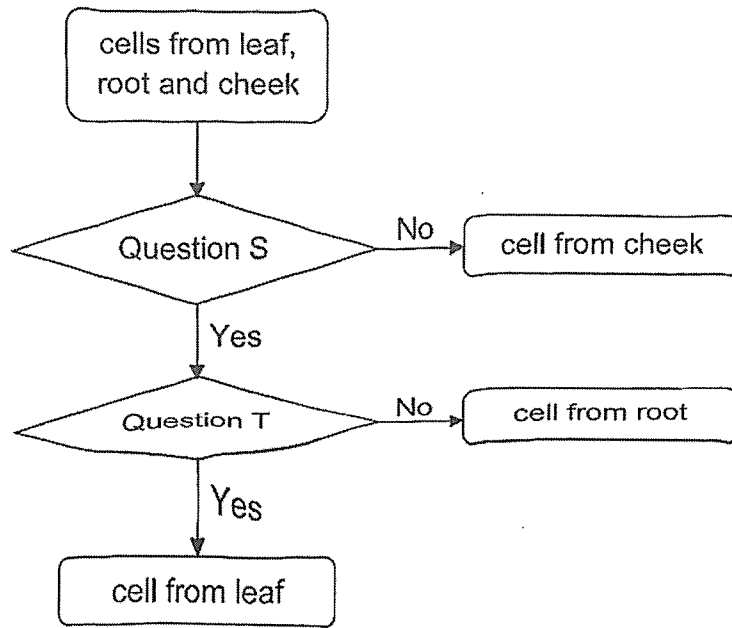

What are questions S and T?

	Question S	Question T
(1)	Does the cell have a nucleus?	Does the cell have a cell membrane?
(2)	Does the cell have a cell wall?	Does the cell have chloroplast?
(3)	Does the cell have chloroplast?	Does the cell have a cell wall?
(4)	Does the cell have a cell membrane?	Does the cell have a nucleus?

10 Which of the following is produced by plants during photosynthesis?

- A food
- B water
- C oxygen
- D carbon dioxide

- (1) A and C only
- (2) B and D only
- (3) A, B and C only
- (4) B, C and D only

11 Study fruits J and K.

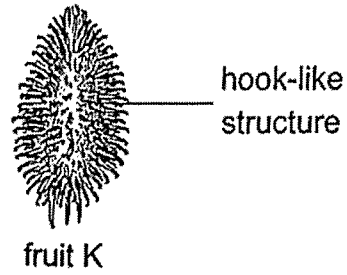
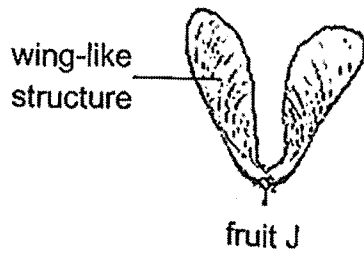

Which graph shows the correct relationship between the wind speed and the average distance away from the parent plant of fruits J and K?

Key

- fruit J
- fruit K

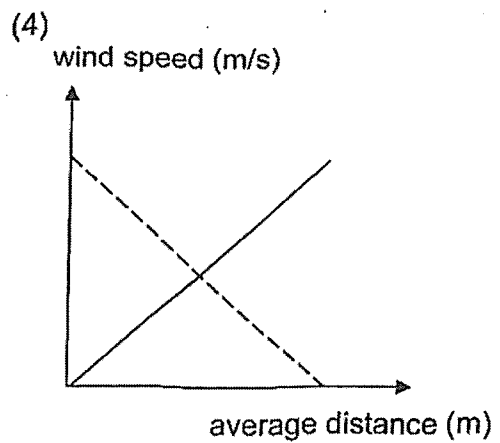
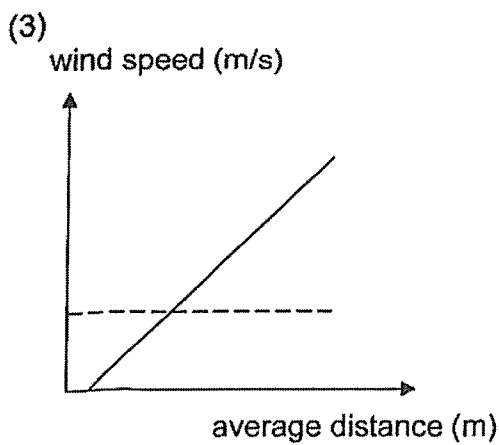
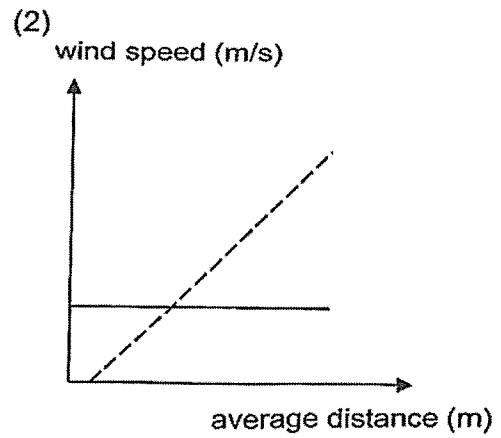
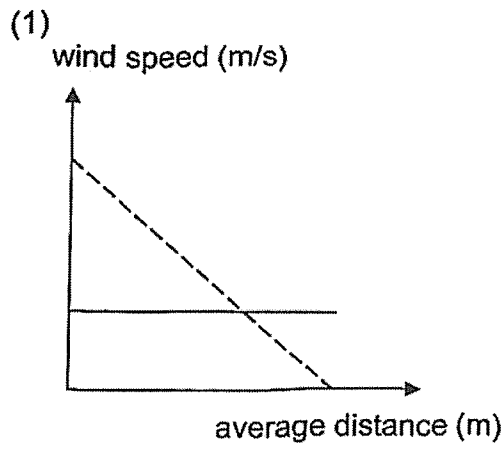

12 Which of the following are correct?

- A using less fuel helps to reduce haze and global warming
- B carrying out reforestation helps to reduce soil erosion and floods
- C preventing disposal of waste into water helps to reduce pollution and haze

- (1) A and B only
- (2) A and C only
- (3) B and C only
- (4) A, B and C

13 The graphs show how the population size of plant K and butterfly L change throughout the year. Given that butterfly L only feeds on the nectar of the flowers of plant K, which graph is correct?

Key

- plant K
- butterfly L

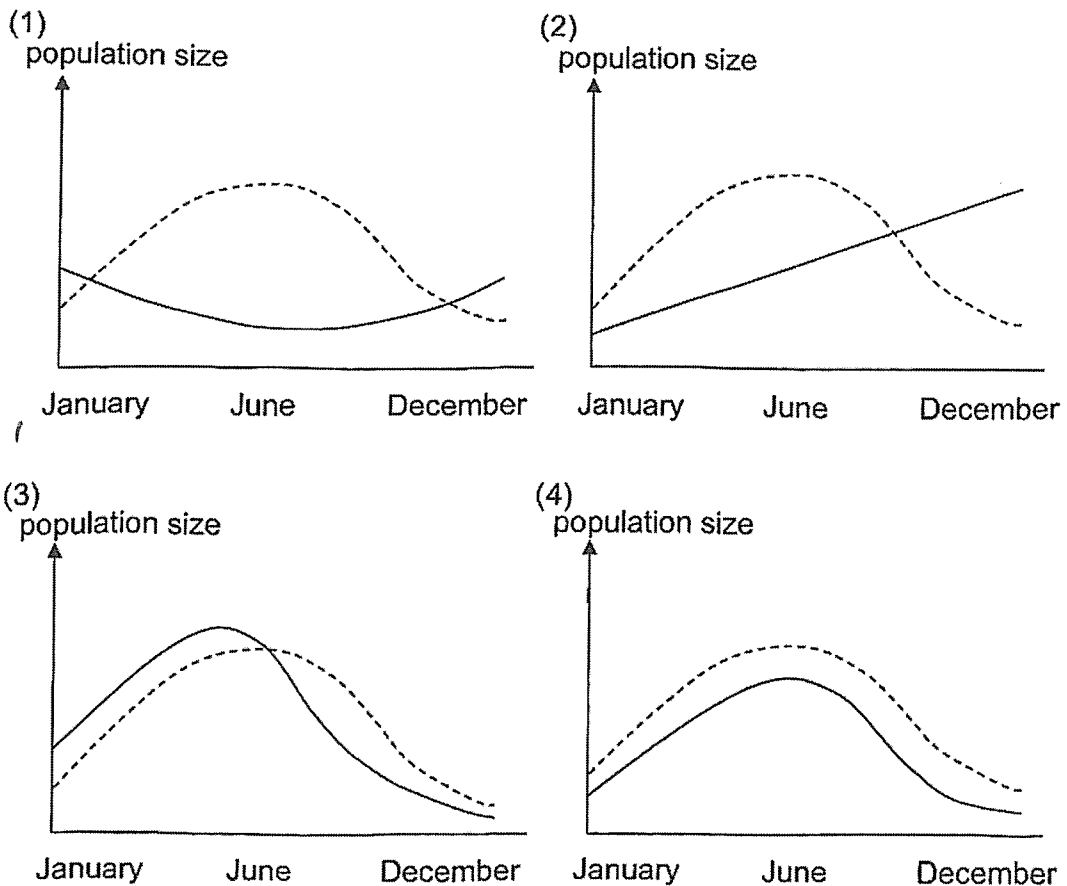

- 14 Set-ups P, Q and R had the same number of similar water plants growing in three similar beakers. Each beaker contains an equal amount of solution, X, Y and Z. The set-ups are left in the sun for two weeks.

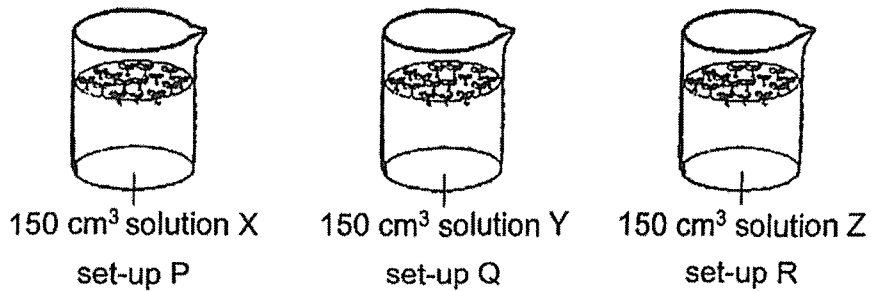

After two weeks, the number of water plants in each set-up are as shown.

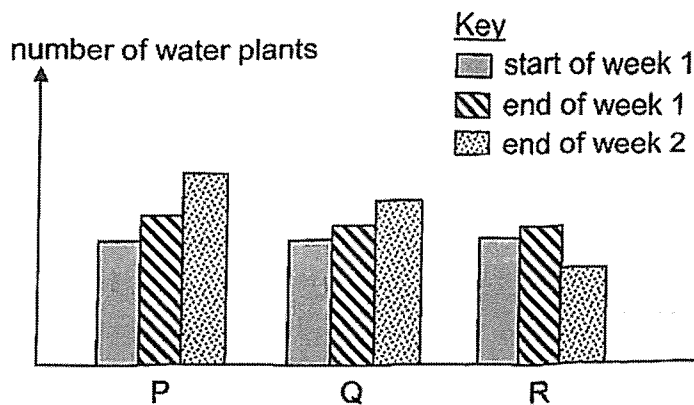

Based on the information, which statement(s) is/are correct?

- A Solution Y can speed up the growth of the water plants.
- B Solution Z can speed up the growth of the water plants.
- C Solution X has the best effect on the growth of the water plants.
- D The use of the solutions is necessary for the growth of the water plants.

- (1) A only
- (2) B only
- (3) A and C only
- (4) A, C and D only

- 15 The diagram shows an inflated balloon attached to a bottle which is placed in a container of hot water

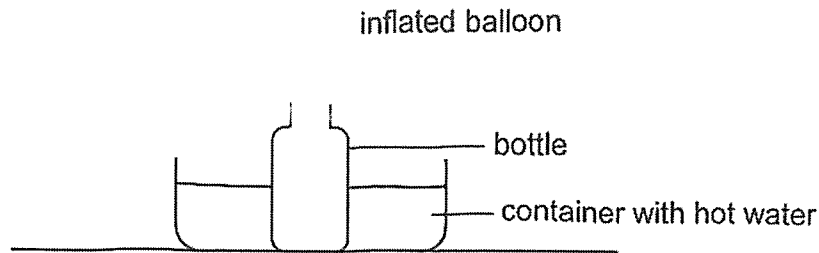

Which of following are the most important properties of the bottle and the balloon for it to become inflated?

	Bottle	Balloon
(1)	transparent	flexible
(2)	transparent	waterproof
(3)	good conductor of heat	flexible
(4)	good conductor of heat	waterproof

- 16 Tricia carried out an experiment using a circuit with similar bulbs, batteries and wires. She tested the circuit and the bulbs lighted up brightly.

She repeated her experiment by increasing variable X and keeping all other variables constant. Her results are as shown.

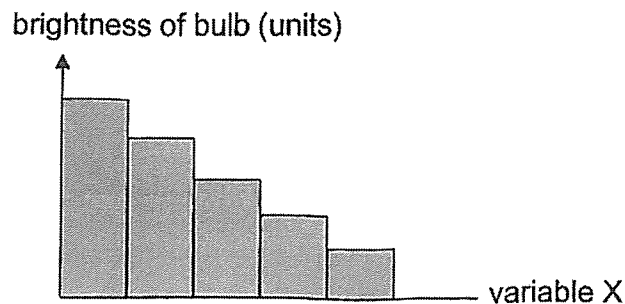

What could variable X be?

- (1) number of wires
- (2) number of bulbs in series
- (3) number of bulbs in parallel
- (4) number of batteries in series

17 Study the table.

Switch M	Switch N	Number of bulbs lighted up
open	open	0
closed	open	1
open	closed	1

Based on the results, which of the following would most likely be the circuit that was constructed?

(1)

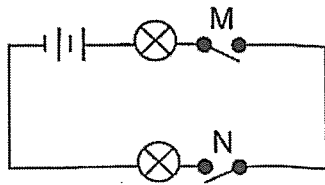

(2)

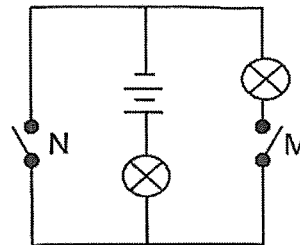

(3)

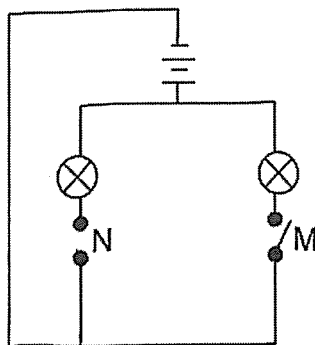

(4)

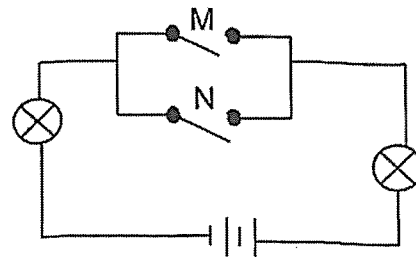

18 Which of the following is **not** an example of matter?

- A air
- B oil
- C ruler
- D shadow

- (1) D only
- (2) A and D only
- (3) B and C only
- (4) A, B and C only

19 Substance P is a solid at 28 °C and a gas at 148 °C.

Which of the following is possible?

	Melting point of P (°C)	Boiling point of P (°C)
(1)	25	155
(2)	25	145
(3)	35	145
(4)	35	155

20 Alice had three towels, R, S and T, which were made of the same material and had the same mass of 50 g. She poured 200 cm³ of water onto each towel and hung them at three different locations around the school.

The graph shows how the mass of towels changed over a period of 30 minutes.

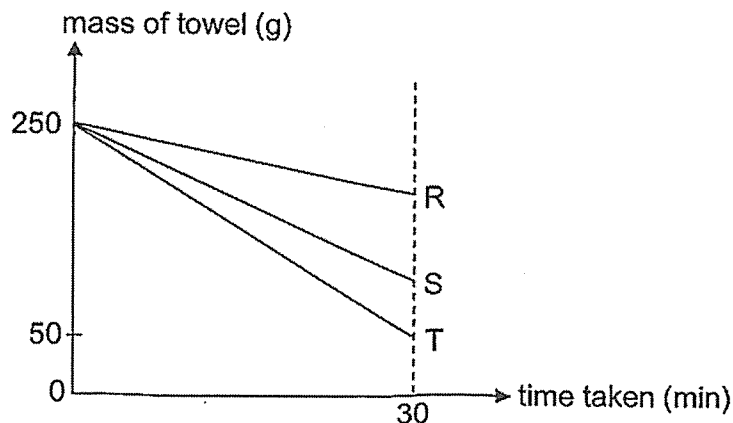

Based on the results, which statements are most likely correct?

- A All the towels were completely dry in 30 minutes.
- B Towel S was placed in a sunny location but not towel R.
- C There was more wind at the location where towel T was than where towel S was.
- D There was a larger exposed area of towel R than towel T to its surroundings.

- (1) A and D only
- (2) B and C only
- (3) A, B and C only
- (4) B, C and D only

- 21 Aishah placed a 10 cm^3 solid metal block at the bottom of a cylinder then filled the cylinder with 20 cm^3 of water. She then placed the plunger back into the cylinder to trap 20 cm^3 of air.

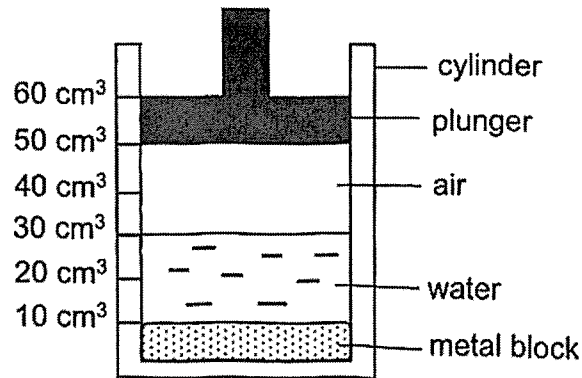

Which of the following would Aishah most likely observe after she pushed the plunger downwards as far as she could without any air or water escaping?

(1)

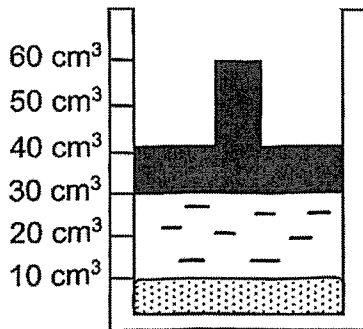

(2)

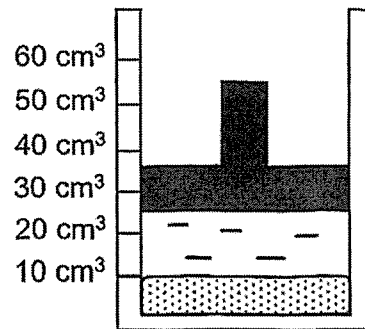

(3)

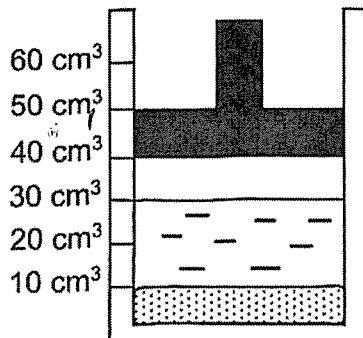

(4)

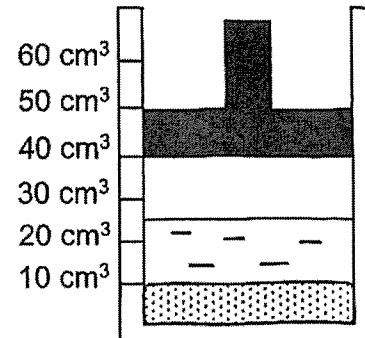

- 22 Linus had a toy which enabled him to see an object at position A when he placed his eye at position B.

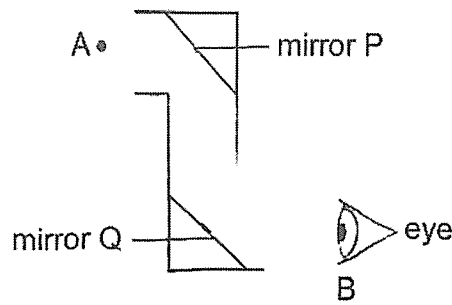

Which of the following shows the path taken by the light rays to enable Linus to see the object at position A?

- (1) eye \longrightarrow mirror Q \longrightarrow object at A
 - (2) object at A \longrightarrow mirror P \longrightarrow eye
 - (3) eye \longrightarrow mirror Q \longrightarrow mirror P \longrightarrow object at A
 - (4) object at A \longrightarrow mirror P \longrightarrow mirror Q \longrightarrow eye
- 23 A loaf of bread takes 30 minutes to be completely baked at 180 °C. Matt uses an oven to bake a loaf of bread at a temperature of 180 °C for 10 minutes.

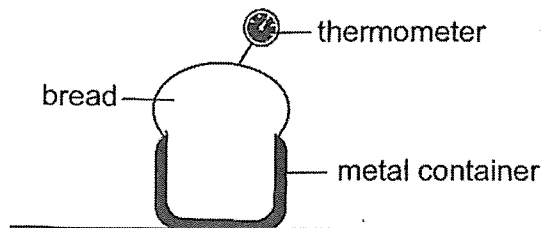

He inserts a thermometer into the centre of the bread immediately to check its temperature. It reads 90 °C.

Which of the following explains why the temperature is still 90 °C even after 10 minutes?

- (1) The bread is a poor conductor of heat so heat is conducted slowly from the air in the oven to the bread.
- (2) The bread is a good conductor of heat so heat is conducted quickly away from the bread to the surroundings.
- (3) The metal container is a good conductor of heat so heat is conducted quickly from the surroundings to the bread.
- (4) The metal container is a poor conductor of heat so heat is conducted slowly from the air in the oven to the bread.

24 Which object possesses kinetic energy?

- (1) a spinning toy
- (2) a twisted spring
- (3) a piece of burning wood
- (4) a pen held above ground

25 Bryan made a toy to launch a ball.

He pulled the plastic tube with the handle in the direction as shown by the arrow and the rubber band became stretched. Once he released his hand, the ball was launched.

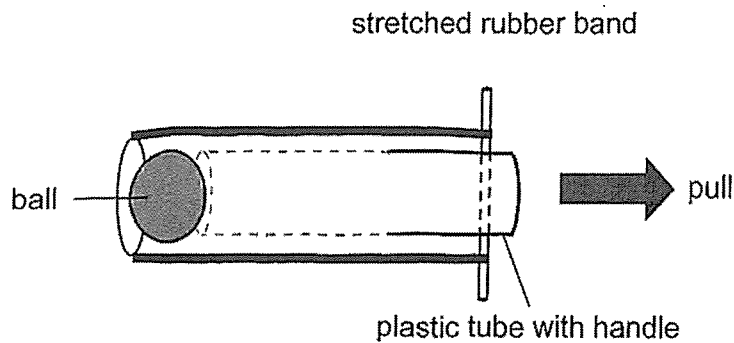

Which of the following shows the correct conversion of energy for the ball to be launched?

- (1) kinetic energy of plastic tube \longrightarrow kinetic energy of ball \longrightarrow potential energy of ball
- (2) potential energy of plastic tube \longrightarrow potential energy of ball \longrightarrow kinetic energy of ball
- (3) potential energy of plastic tube \longrightarrow kinetic energy of rubber band \longrightarrow kinetic energy of ball
- (4) kinetic energy of plastic tube \longrightarrow potential energy of rubber band \longrightarrow kinetic energy of ball

- 26 A boy gave a kick to a block of ice. The block of ice moved along the floor to P and then to Q. It stopped at Q.

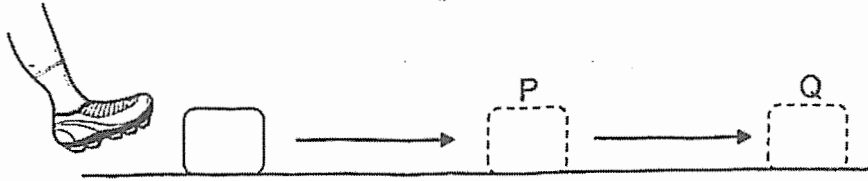

Which of the following is correct?

Key

✓ : present

Forces acting on the block of ice at			
P		Q	
Friction	Weight	Friction	Weight
(1)	✓	✓	✓
(2)	✓		✓
(3)	✓	✓	✓
(4)	✓	✓	✓

27 A magnet is placed on an electronic balance as shown in diagram 1.

The reading on the electronic balance changes when another magnet or an iron bar is held close to the first magnet.

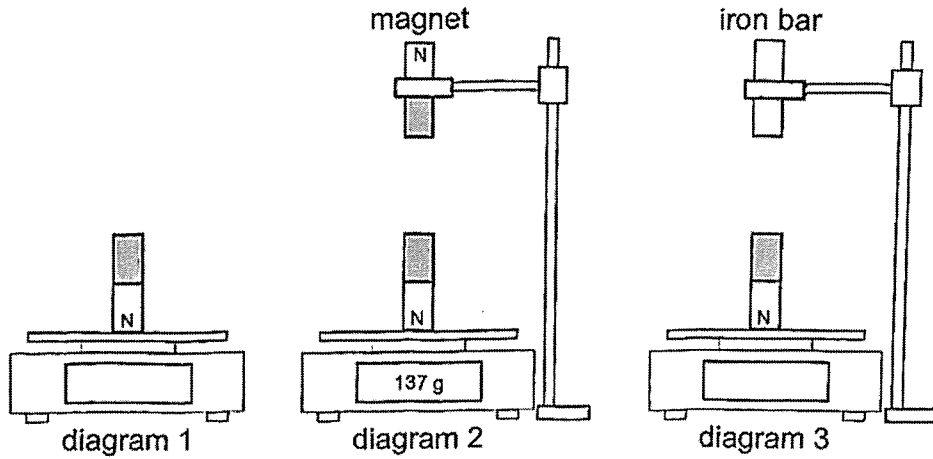

Which of the following shows the possible readings for diagrams 1 and 3?

Readings on the electronic balance (g)		
	Diagram 1	Diagram 3
(1)	90	more than 137
(2)	90	less than 137
(3)	150	more than 137
(4)	150	less than 137

- 28 Zi Yue wanted to compare the elastic spring force of springs of the same length when compressed.

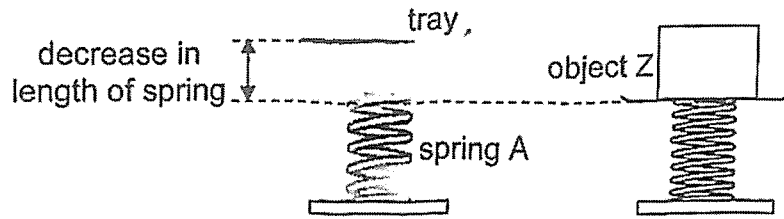

She placed object Z on spring A and measured how much the spring decreased in length. The same experiment was repeated using springs, B, C and D, and the results were recorded as shown.

Spring	Mass of object (g)	Decrease in length of spring (cm)
A	100	1.1
B	100	3.4
C	100	2.8
D	100	4.0

If the springs were hung using four identical blocks, which of the following shows the correct results?

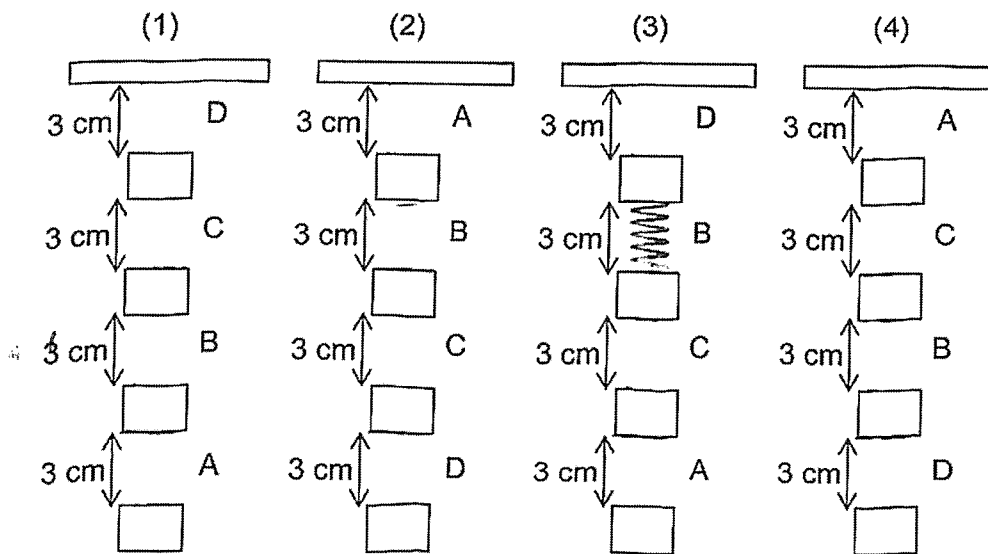

End of Booklet A

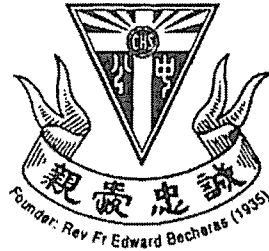

CATHOLIC HIGH SCHOOL
PRELIMINARY EXAMINATION (2024)
PRIMARY SIX
SCIENCE
BOOKLET B

Name: _____ ()

Class: Primary 6 - _____

Date: 22 August 2024

Parent's Signature: _____

Booklet A	56
Booklet B	44
Total	100

12 questions

44 marks

Total Time for Booklets A and B: 1 hour 45 minutes

INSTRUCTIONS TO CANDIDATES

Do not turn over this page until you are told to do so.
Follow all instructions carefully.
Answer all questions.
Write your answers in this booklet.

This booklet consists of 19 printed pages, excluding the cover page.

Booklet B (44 marks)

For questions 29 to 41, write your answers in this booklet.

The number of marks available is shown in brackets [] at the end of each question or part question. (44 marks)

29 Study the three human body systems, P, Q and R.

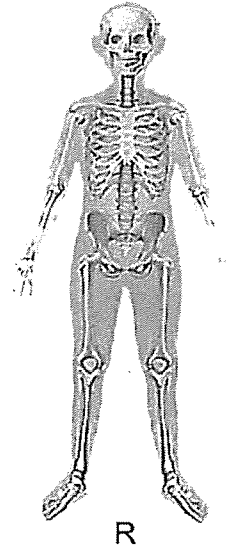
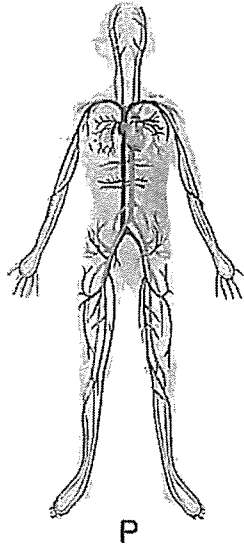

(a) Identify the body system (P, Q or R) that has the same function as the plant transport system. [1]

(b) State a difference between the direction of movement of water in plants and the direction of movement of blood in humans. [1]

(c) A plant cell has a part which serves the same function as body system R. Name and state the function of this part. [1]

(Go on to the next page)

SCORE	3
-------	---

- 30 The diagram shows a four-tray garden composter where materials to be decomposed are placed into the top tray.

Each tray has holes at the bottom. As the material breaks down, it drops through the holes which get smaller from the top to the bottom tray.

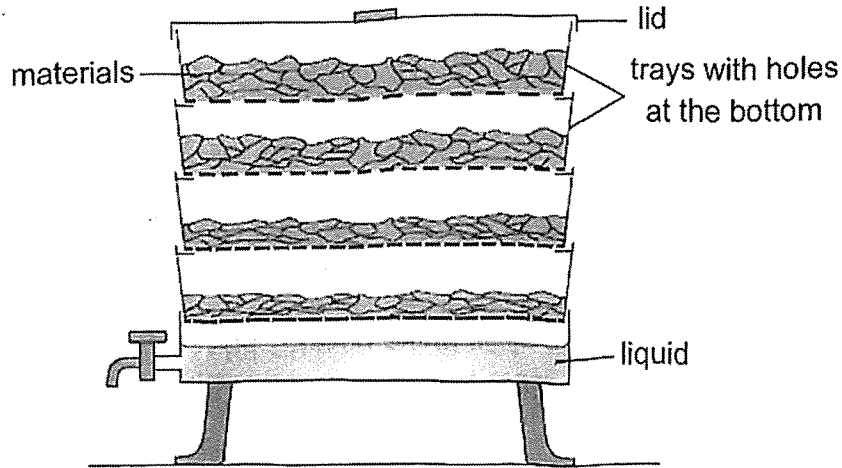

- (a) Suggest one type of material that can be placed into the composter. [1]

- (b) State why plants that are given the liquid from the composter grow healthier than plants that are given tap water. [1]

- (c) Explain one other environmental benefit of composting. [1]

(Go on to the next page)

SCORE	3
-------	---

31 (a) Draw the life cycle of a butterfly in the space given.

[1]

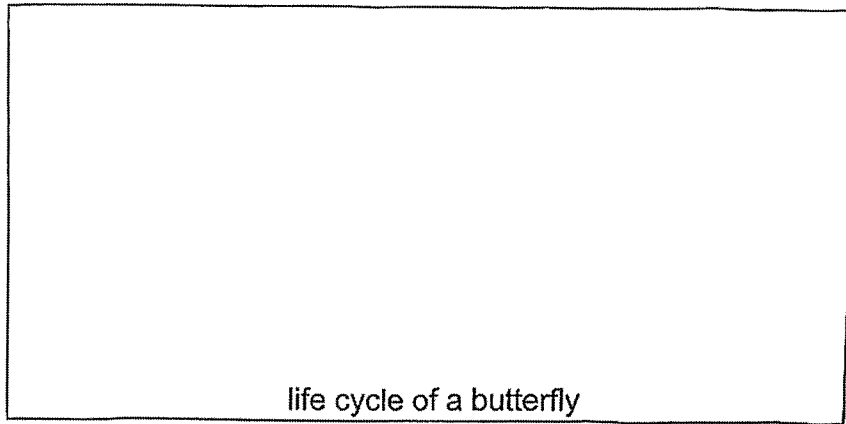

One of the stages of the life cycle of the butterfly plays an important role in process X that helps in the reproduction of flowering plants.

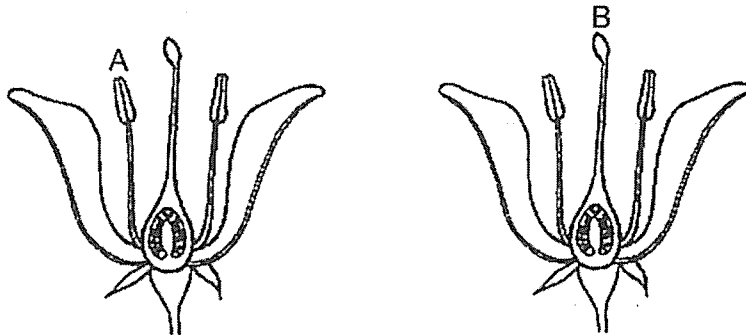

(b) Using your answer in (a), identify the stage in the life cycle of the butterfly and how parts A and B of the two flowers from the same plant are involved in process X.

[1]

(Go on to the next page)

SCORE	2
-------	---

Continue from Question 31

Four different varieties of a type of plant grown produced different number of seeds in a pod.

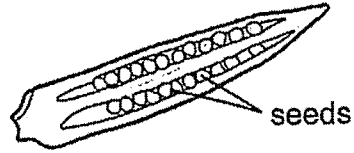

Variety	Number of seeds
E	15
F	10
G	13
H	11

- (c) Other than environmental factors, suggest a factor that could have resulted in the different number of seeds produced in the pod. [1]
-

(Go on to the next page)

SCORE	1
-------	---

- 32 A scientist used the set-up to study the effect of wind speed on the rate of absorption of water in a plant.

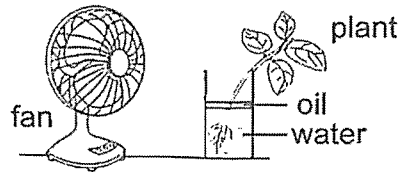

He measured the changes in the size of the tiny openings on the leaves at fixed time intervals and the amount of water left in the container at the end of the experiment. His results are as shown.

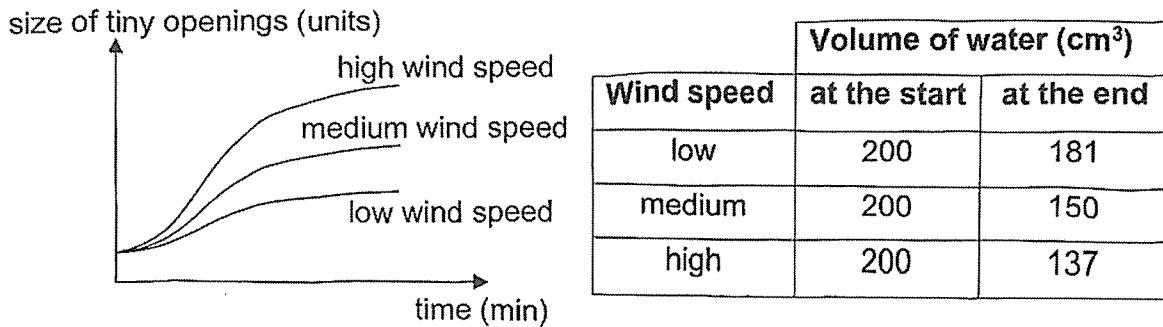

- (a) Based on the results, explain how the change in wind speed affects the rate of absorption of water in a plant. [2]

Another experiment was carried out using the set-ups, W, X, Y and Z.

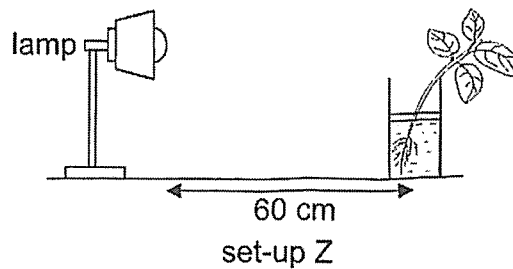
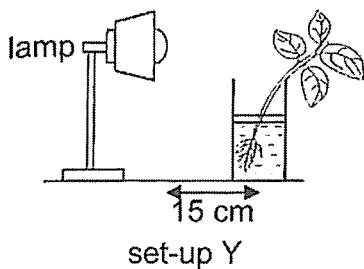
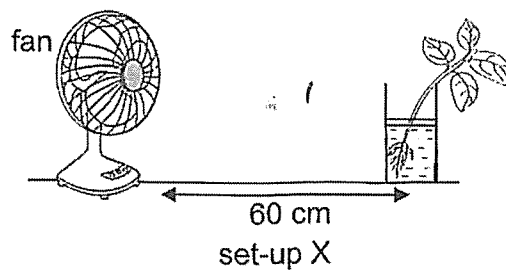
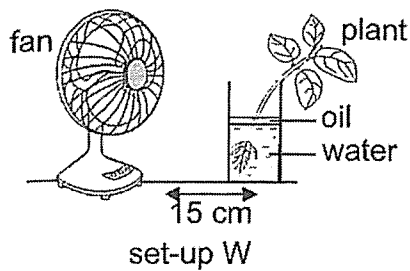

(Go on to the next page)

SCORE	2
-------	---

Continue from Question 32

The graph shows the amount of water in the containers over a period of time.

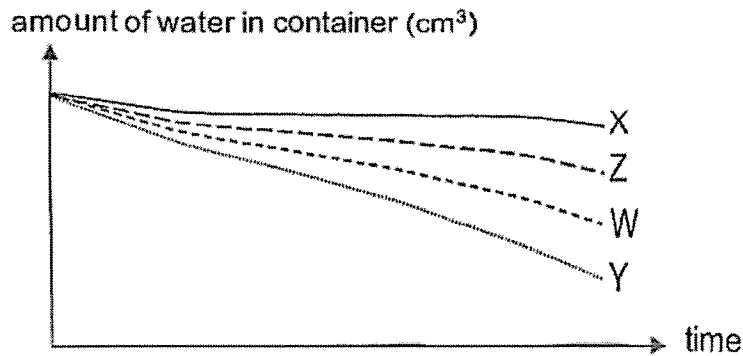

- (b) Based on the graph, did light or wind have a greater effect on the amount of water left in the container? Give a reason. [1]

- (c) A plant growing in a sunny area was observed to have smaller leaves than the same type of plant growing in a shaded area.

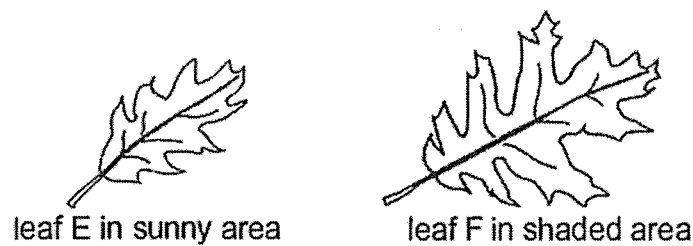

- Based on the second experiment, explain why leaf E was smaller in size than leaf F [1]

(Go on to the next page)

SCORE	2
-------	---

- 33 Ming En carried out an experiment in a dark room to find out how the height of three similar plants was affected by the amount of light they had been exposed to for four days.

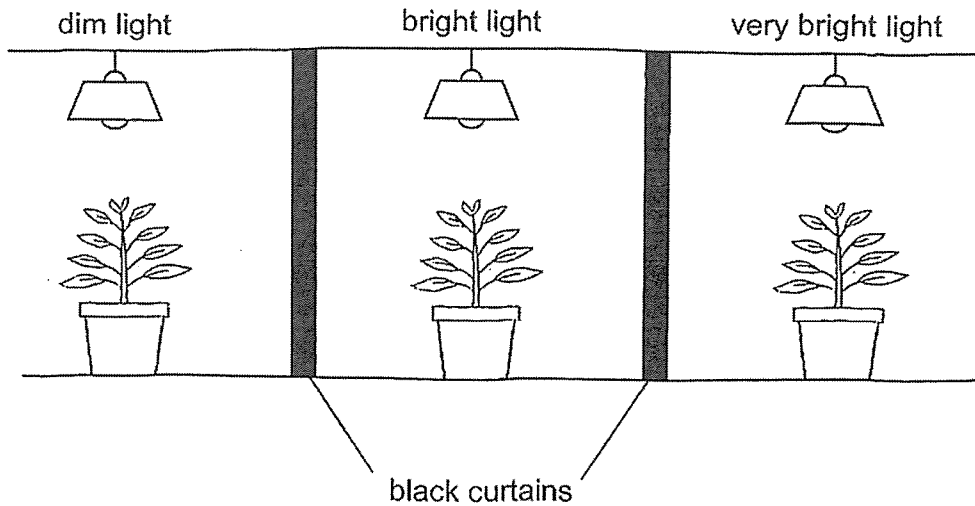

The results are as shown.

Amount of light	Height of the plant (cm)	
	Start of the experiment	End of the experiment
dim	10	11
bright	10	13
very bright	10	15

- (a) Based on the results, state how the amount of light affects the height of the plants. [1]

- (b) Suggest what Ming En should do to obtain more reliable results. [1]

(Go on to the next page)

SCORE	2
-------	---

- (c) State one variable that Ming En should keep constant when carrying out the experiment. [1]

- (d) When all the light bulbs used by Ming En had fused from the start of the experiment, he observed that the plants turned yellow after a few weeks. Explain why. [1]

(Go on to the next page)

SCORE	2
-------	---

34 The table shows the energy available to animal C from two different food chains.

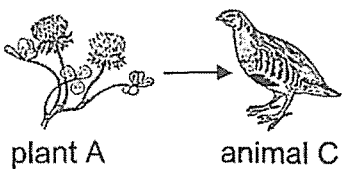
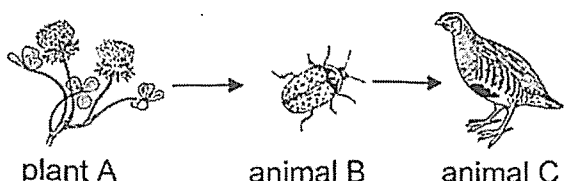
Food chain	Energy transferred from plant A to animal C (unit)
 <p>plant A → animal C</p>	1000
 <p>plant A → animal B → animal C</p>	100

(a) Based on the information given, explain why there is a difference in the amount of energy transferred from plant A to animal C in each food chain.

[1]

Animal C is exposed to different predators at all stages of its life cycle.

It builds its nest on the ground, hidden among thick grass and dead leaves. At times, there may be trees present around these nesting areas and this may affect the survival of animal C as shown.

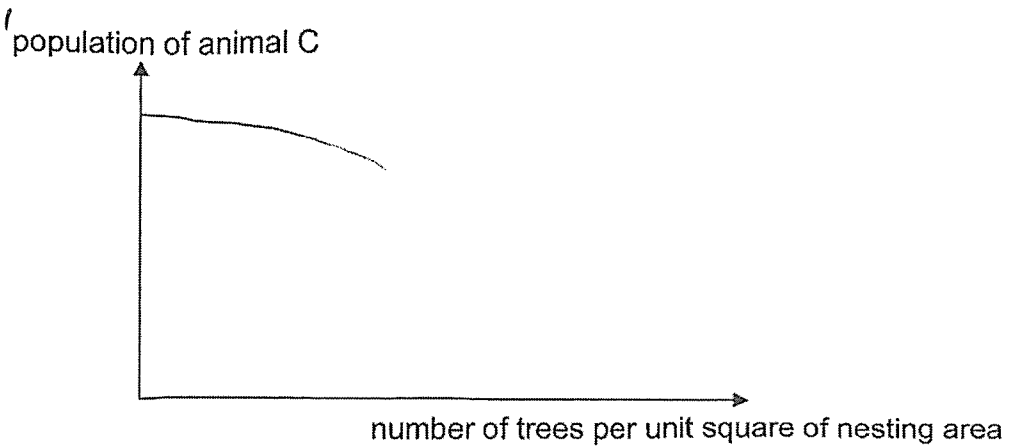

(Go on to the next page)

SCORE	1
-------	---

Continue from Question 34

- (b) Based on the information given, state how the number of trees per unit square of the nesting area impacts the survival of animal C. Suggest a possible reason for this other than the lack of space in the nesting area. [2]

The diagram shows how animals C sit close together facing outwards when they rest in the open during the day.



- (c) Identify the type of adaptation and explain why sitting in such an arrangement helps animals C to survive. [2]

Type of adaptation: _____

Explanation: _____

(Go on to the next page)

SCORE	4
-------	---

35 Firemen wear the clothing as shown when they put out fires.

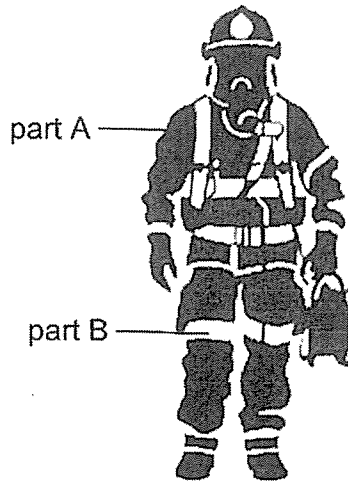

(a) State two properties of the material used to make part A. [2]

(b) During a fire, the surroundings may be filled with lots of smoke reducing one's ability to see well.

Part B is shiny and enables one to see the firemen more clearly. Explain why. [1]

(Go on to the next page)

SCORE	3
-------	---

36 The diagram shows part of a circuit in a camera.

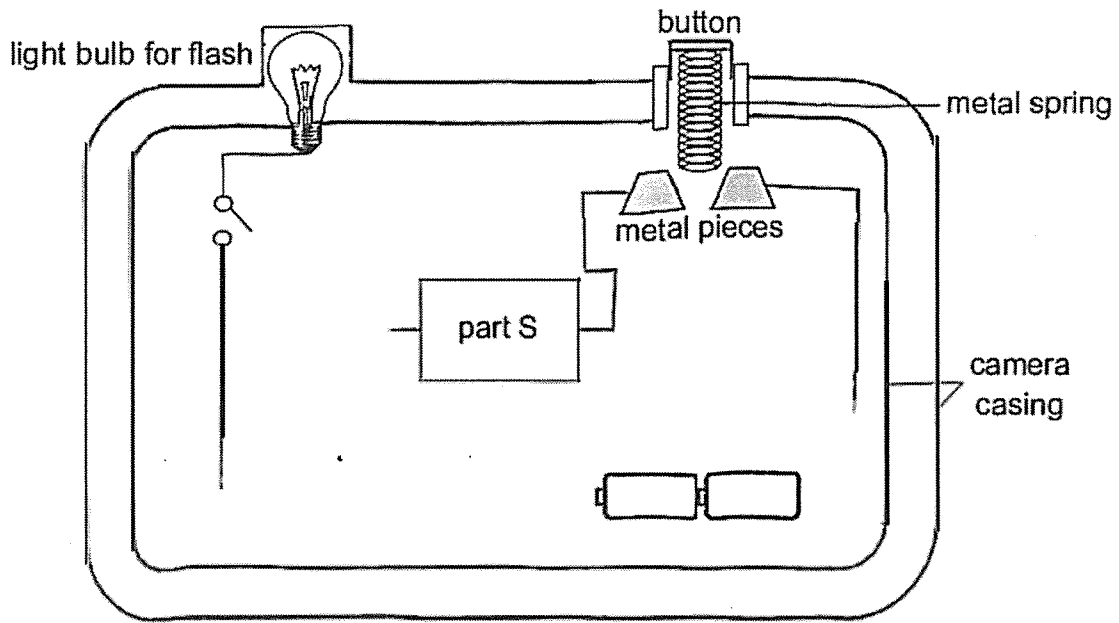

To take a photograph, part S needs to be connected in a closed circuit with the button being pressed down. The photograph can also be taken by the camera with or without the use of a flash.

(a) Using some wires, complete the circuit in the diagram above so that the camera will work as described. [2]

(b) Suggest a disadvantage of the circuit in (a). [1]

(c) If the metal pieces are switched to plastic pieces, will the camera still work? Explain why. [1]

(Go on to the next page)

SCORE	4
-------	---

- 37 Adirah had three different types of paper, A, B and C. She shone a torch at each paper and recorded the amount of light passing through for 10 s.

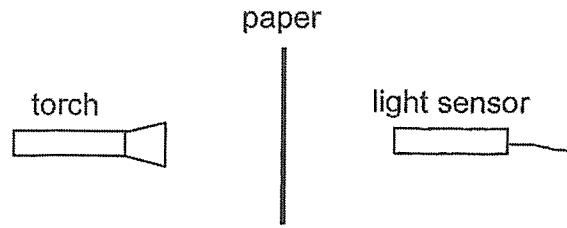

Her observations are as shown.

Paper	Amount of light passed through
A	some light
B	most light
C	very little light

- (a) Using the information given, fill in the boxes with the letters, A, B and C, in the graph to indicate which line represent the different types of paper. [1]

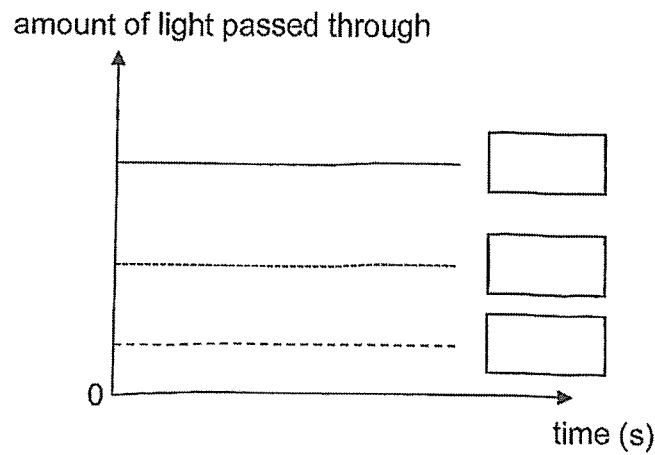

(Go on to the next page)

SCORE	1
-------	---

Continue from Question 37

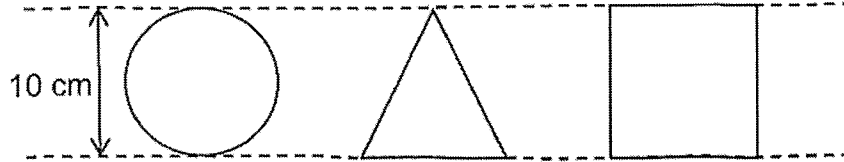

Adirah cut the papers into different shapes of equal heights of 10 cm.

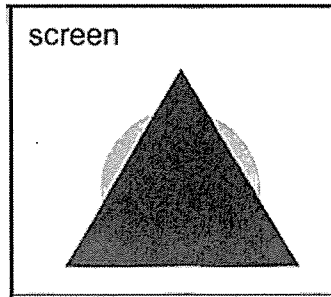

She hung the cut-out shapes at different distances in front of a torch and observed the shadow cast on a screen as shown.

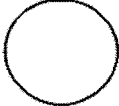

(b) Match the different cut-out shapes to the types of paper, A, B and C. [1]

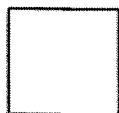
Cut-out shapes	Types of paper
	
	
	

(c) Suggest a control set-up to show that the change in the amount of light is due to the types of papers used. [1]

(Go on to the next page)

SCORE	2
-------	---

- 38 Gopal placed two glass cups, X and Y, wet with water one on top of another in a freezer for a few hours.

When he first took out the glass cups from the freezer, he could not remove cup X from cup Y. He observed that solid W had formed at some parts between the glass cups as shown.

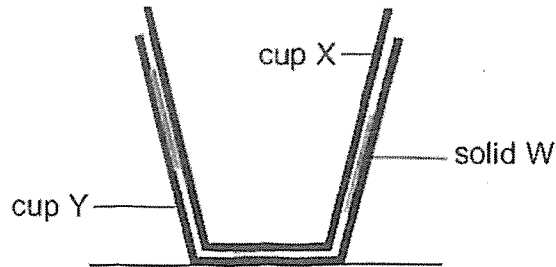

- (a) Explain how solid W formed when glass cups X and Y were left in the freezer. [1]

A few minutes after removing both glass cups from the freezer, Gopal observed that more tiny water droplets formed on the surfaces of cups X and Y where solid W was present than where solid W was absent.

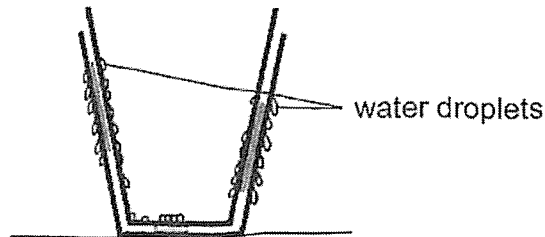

- (b) Explain the observation. [2]

(Go on to the next page)

SCORE	3
-------	---

Continue from Question 38

- (c) Without breaking the glass cups or using any other materials, suggest what Gopal can do to separate cup X from cup Y in the shortest time. [1]

(Go on to the next page)

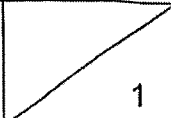
SCORE	
-------	---

39 Study the toy dispenser as shown.

The iron bar and the electric circuit are fixed in place while the magnet is attached to a spring. When the metal button is pressed, the magnet will move to the left, away from the iron bar.

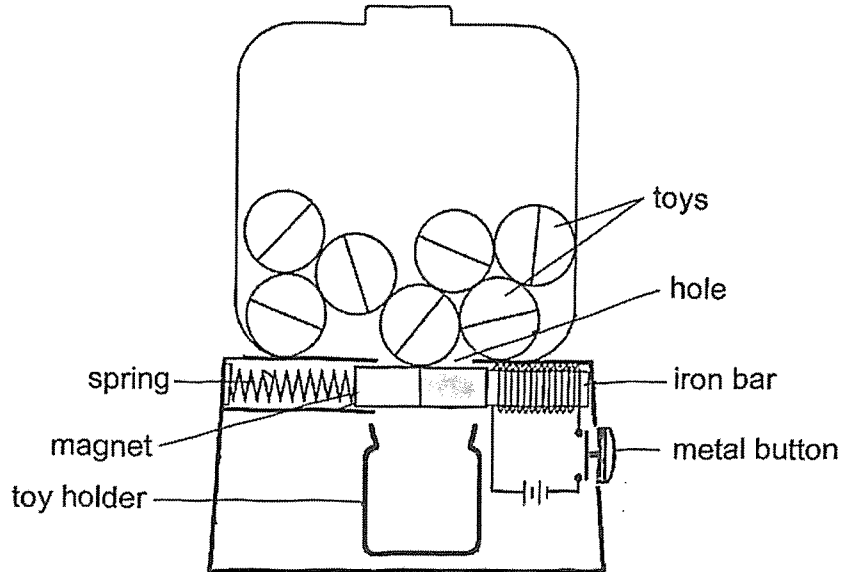

(a) Name the force(s) acting on the magnet when the metal button is **not** pressed. [1]

(b) Explain how a toy can drop through the hole into the toy holder when the metal button is pressed. [2]

(Go on to the next page)

SCORE	3
-------	---

continue from Question 39

When the metal button is **not** pressed, the spring will push the magnet back to the right to close the hole.

- (c) Suggest two changes that can be made to the dispenser to ensure that the hole is closed more quickly so that only one toy drops into the holder. Explain why. [2]

Suggestion: _____

Reason: _____

Suggestion: _____

Reason: _____

(Go on to the next page)

SCORE	2
-------	---

- 40 The diagram shows an electric scooter that is plugged into a power source to recharge its battery.

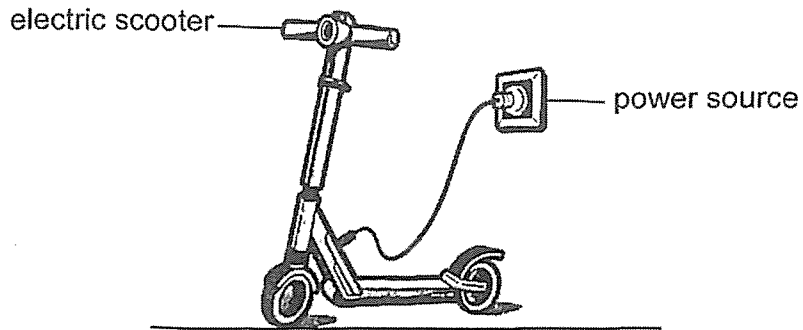

- (a) Fill in the boxes to show the conversion of energy when the electric scooter is recharging its battery. [1]

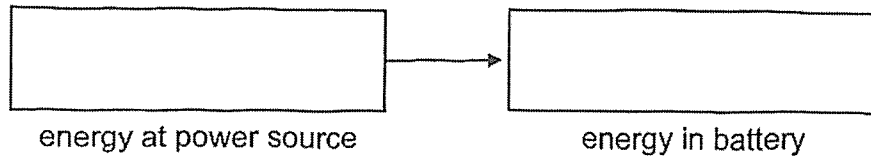

- (b) After using the electric scooter for several hours, its battery needs to be recharged again.

Explain how the amount of energy in the battery changes in the fully charged battery of the electric scooter after several hours of use. [2]

End of Booklet B

SCORE	3
-------	---

SCHOOL : CATHOLIC HIGH PRIMARY SCHOOL
LEVEL : PRIMARY 6
SUBJECT : SCIENCE
TERM : 2024 PRELIMINARY EXAMINATION

Booklet A

Q1	Q2	Q3	Q4	Q5	Q6	Q7	Q8	Q9	Q10
2	4	3	3	2	1	1	4	2	1
Q11	Q12	Q13	Q14	Q15	Q16	Q17	Q18	Q19	Q20
2	1	4	3	3	2	3	1	3	2
Q21	Q22	Q23	Q24	Q25	Q26	Q27	Q28		
3	4	1	1	4	4	2	4		

Booklet B

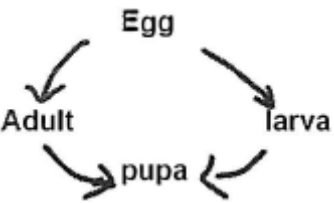
Q29a	P
Q29b	In plants, water is transported in one direction upwards from the roots to all parts of the plant while in humans, substances are transported in the blood in double circulation.
Q29c	Cell wall. To give the plant cell its regular shape.
Q30a	Fruit peels
Q30b	The dead organic matter is broken down into simple substances such as nutrients which act as fertiliser for the plants to grow better and healthier.
Q30c	Composting helps reduce the amount of waste that goes to landfills. When we compost, we turn things like food scraps and leaves into nutrient-rich soil instead of throwing them away. This reduces the amount of garbage that would otherwise take up space in landfills and produces harmful gases like methane, which contribute to global warming. So, composting helps keep the environment cleaner and healthier.
Q31a	 <pre> graph TD Egg --> larva larva --> pupa pupa --> Adult Adult --> Egg </pre>

(b)	Adult. Pollen grains from part A, the anther, are transferred by the adult butterfly to part B, the stigma of the flower. For successful pollination.
(c)	Number of ovules in the ovary.
Q32(a)	<p>When the wind speed increases, it causes more water to evaporate from the leaves of a plant. To replace the lost water, the plant absorbs more water from the soil through its roots. So, when there's more wind, the plant has to absorb water faster to keep itself hydrated. However, if the wind is too strong and the plant can't absorb water quickly enough, it might start to dry out.</p> <p>In summary, an increase in wind speed generally makes a plant absorb water faster to keep up with the higher rate of evaporation.</p>
(b)	<p>The line labelled Y shows a steeper decline compared to the other lines (X, Z, and W), indicating that the water evaporated more quickly. If the graph is comparing the effects of different conditions, this steeper decline suggests that the condition represented by Y (likely wind) caused the most significant reduction in the amount of water, meaning wind had a greater effect on the evaporation rate.</p> <p>If Y corresponds to wind and X, Z, or W correspond to light or other factors, then it would indicate that wind has a stronger influence on the rate at which water evaporates from the container.</p>
(c)	<p>In contrast, a plant growing in a shaded area receives less light, so it might develop larger leaves to capture more light for photosynthesis. The larger leaf surface area helps the plant maximize light absorption in low-light conditions, which explains why the leaf in the shaded area is larger than Leaf E in the sunny area.</p>
Q33(a)	As the amount of light increases, the height of the plants at the end of the experiment increases.
(b)	Repeat the experiment two more times and calculate the average height of the plant for each amount of light.
(c)	Amount of water given to each plant.
(d)	When all the light bulbs fused in the dark room, the leaves could not trap any light and could not make food through photosynthesis, causing the plant to die due to lack of food.

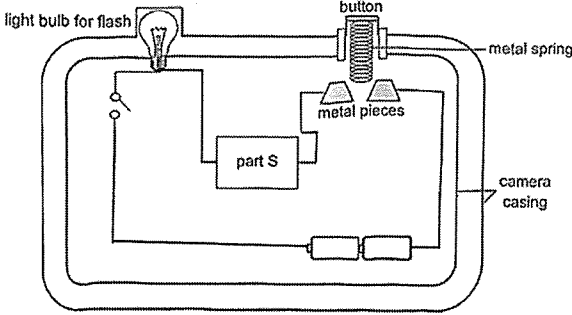
<p>Q34(a)</p>	<p>The difference in the amount of energy transferred from Plant A to Animal C in each food chain is likely due to the number of steps or organisms between them. In a food chain, energy is lost at each level, usually as heat, when one organism eats another.</p>
<p>(b)</p>	<p>As the number of trees per unit square increases, the chances of animal C surviving decreases.</p>
<p>(c)</p>	<p>Type of adaptation: <i>Behavioural</i> Explanation: Predators coming from any direction will be spotted decreasing the chances of animal C being hunted and eaten.</p>
<p>Q35(a)</p>	<p>Flexible, poor conductor of heat.</p>
<p>(b)</p>	<p>Part B is shiny, which means it reflects light well. During a fire, the area can be filled with smoke, making it difficult to see clearly because smoke scatters light and reduces visibility. However, because Part B is shiny, it reflects any available light, making it easier for someone to see the firemen wearing it. The reflected light from the shiny surface makes the firemen more visible, even in smoky conditions. This is why Part B helps in seeing the firemen more clearly during a fire.</p>
<p>Q36(a)</p>	
<p>(b)</p>	<p>A disadvantage of the circuit described in (a) could be that if part S is always connected in a closed circuit when the button is pressed down, the camera might take a photograph even when the flash is not needed or desired. This could result in unnecessary use of the flash, which might drain the camera's battery faster or cause overexposure in bright conditions. Additionally, if the flash goes off in situations where it is not needed, it could affect the quality of the photograph by creating unwanted reflections or harsh lighting.</p>
<p>(c)</p>	<p>No. Plastic is an electrical insulator, hence there will be an open circuit</p>

	where electric current cannot flow through the circuit, hence part S and the light bulb does not work.			
Q37(a)	<table border="1" style="margin-left: 20px;"> <tr><td style="text-align: center;">B</td></tr> <tr><td style="text-align: center;">A</td></tr> <tr><td style="text-align: center;">C</td></tr> </table>	B	A	C
B				
A				
C				
(b)	<table border="1" style="margin-left: 20px;"> <tr><td style="text-align: center;">A</td></tr> <tr><td style="text-align: center;">C</td></tr> <tr><td style="text-align: center;">B</td></tr> </table>	A	C	B
A				
C				
B				
(c)	By comparing the light readings from the experimental set-up with the control set-up (where no paper is used), you can determine how much the different types of paper affect the amount of light passing through. If there's a significant difference between the control and the experimental readings, you can conclude that the change in light is due to the types of papers used.			
Q38(a)	The water drop lets on cups X and Y had lost heat to the colder air in the freezer and froze.			
(b)	The observation that more tiny water droplets formed on the surfaces of cups X and Y where solid W was present is likely due to the fact that solid W is a better conductor of heat than the material where solid W is absent.			
(c)	Place his hands on cup Y.			
Q39(a)	Gravitational Force			
(b)	When the metal button is pressed, a closed circuit is formed where electric current flows through the iron bar, turning it into an electromagnet. The like poles of the magnet and electromagnet are facing each other, causing them to repel and the magnet will move to the left, creating a space where the toys can drop into the toy holder.			
(c)	<p>Suggestion: Use a stiffer spring. Reason: The spring will exert a greater elastic spring force on the magnet, pushing it to close the hole more quickly.</p> <p>Suggestion: Phrasing. Magnet with greater magnetic strength. Reason: The magnet will exert a greater magnetic force of attraction on the iron bar, going towards the iron bar to close the hole more quickly.</p>			

Q40a)

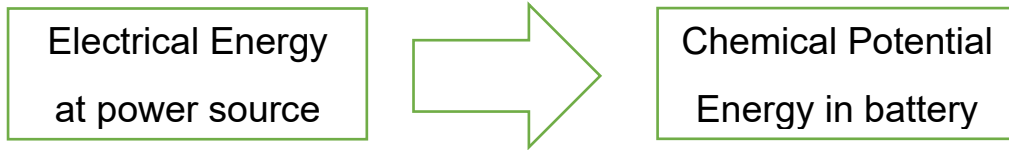

b) After using the electric scooter for several hours the amount of potential energy in the battery decreases with time as it was converted into kinetic energy.