



MAHA BODHI SCHOOL
2025 END OF YEAR EXAMINATION
PRIMARY THREE SCIENCE
(BOOKLET A)

Name : _____ ()

Class : Primary 3 _____

Date : 27 Oct 2025

Total Duration for Booklets A and B: 1 h 30 min

INSTRUCTIONS TO CANDIDATES:

1. Do not turn over this page until you are told to do so.
2. Follow all instructions carefully.
3. Answer all questions.
4. Shade your answers in the Optical Answer Sheet (OAS) provided.

BOOKLET A : [24 x 2 marks = 48 marks]

For each question from 1 to 24, four options are given. One of them is the correct answer. Make your choice (1, 2, 3 or 4). Write your answer in the bracket below.

1. Which of the following has non-living things only?
 - (1) carpet, ruler and magnet
 - (2) bread mould, kite and toy train
 - (3) plastic spoon, hamster and oven
 - (4) bird's nest fern, bacteria and durian tree

2. When Thomas touched the tortoise's head, it hid itself in its shell.

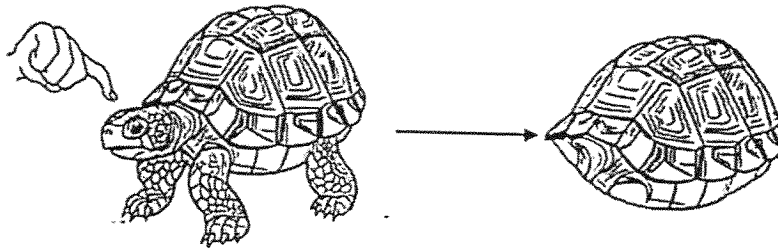

This shows that the tortoise is a living thing because it

- (1) grows
- (2) reproduces
- (3) responds to changes
- (4) needs water, food and air

3. Observe the two groups of plants below carefully.

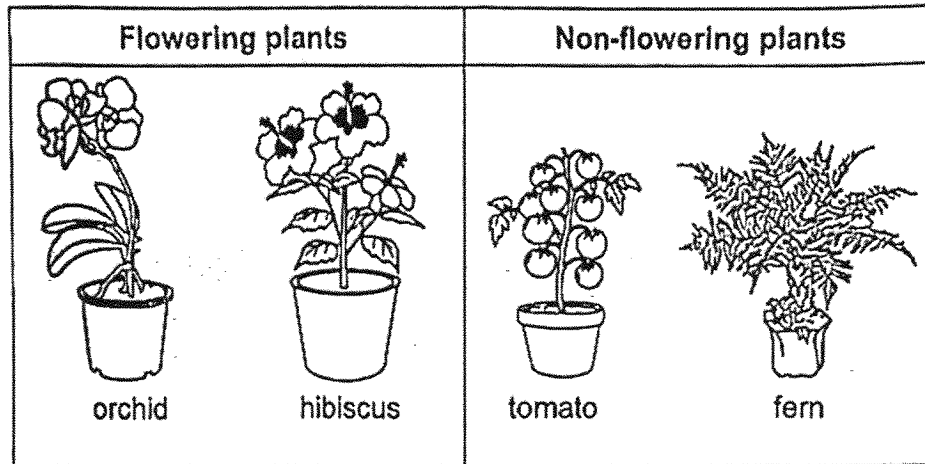

Which of the following plants has been grouped wrongly?

- (1) orchid
- (2) hibiscus
- (3) tomato
- (4) ladder fern

4. Which of the following shows the correct characteristics of flowering and non-flowering plants?

	Flowering plants	Non-flowering plants
(1)	make their own food	do not make their own food
(2)	do not attract insects	attract insects
(3)	produce spores	do not produce spores
(4)	produce fruits	do not produce fruits

5. What is the similarity between reptiles and birds?

- (1) They have three body parts.
- (2) They reproduce by laying eggs.
- (3) Their young do not look like the adults.
- (4) They have the same type of body covering.

6. Study the animal below.

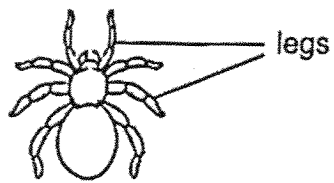

The animal shown above is not an insect because _____

- (1) it cannot fly
 - (2) it has six legs
 - (3) it can live in water
 - (4) it has two body parts
7. Which of the statements about fungi and bacteria is correct?
- (1) Bacteria are found in food only.
 - (2) All fungi cause harm to humans.
 - (3) We use fungi to help us make yogurt.
 - (4) Bacteria are so small that we need to use a microscope to see them.
8. Which material is used to make part X of the drink can below so that it will not break easily?

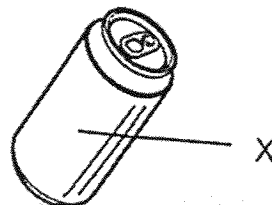

- (1) fabric
- (2) glass
- (3) metal
- (4) ceramic

9. The picture below shows parts of a face mask.

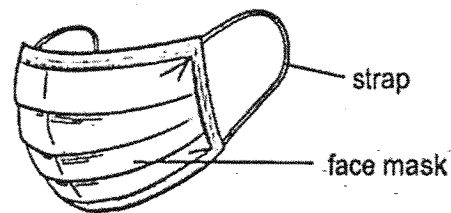

The strap is made of rubber because it is _____.

- (1) light
 - (2) flexible
 - (3) transparent
 - (4) able to float
10. Study the diagram below.

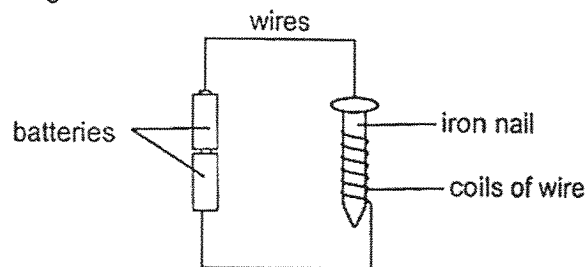

How do you increase the strength of an electromagnet?

- (1) use a copper nail
- (2) use less batteries
- (3) use a bigger iron nail
- (4) increase the number of coils of wires around the iron nail

11. A bar magnet is brought near to a plate of staples as shown below.

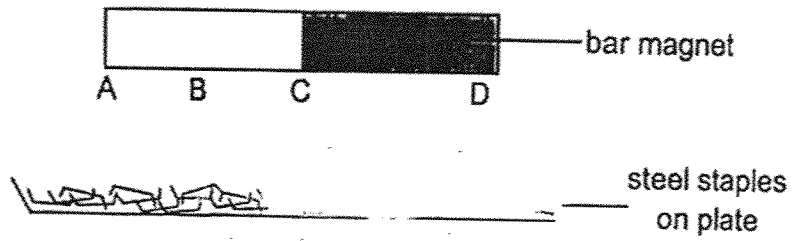

Which two parts of the magnet will have the greatest number of staples attracted to it?

- (1) A and B
- (2) A and D
- (3) B and C
- (4) C and D

12. Which of the following diagrams shows the correct stroke method?

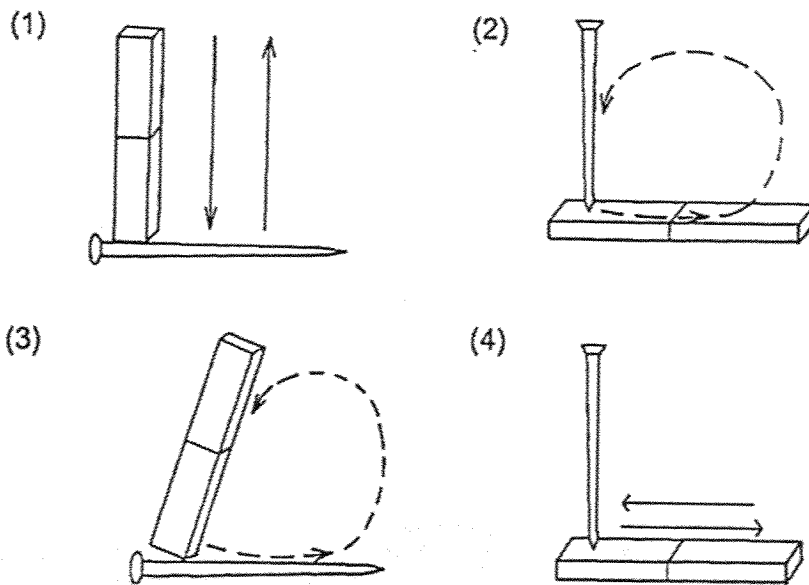





13. Which of the following statements about the life cycles of grasshopper and cockroach are both correct?

	Characteristic	Grasshopper	Cockroach
(1)	The young hatch from eggs.	Yes	No
(2)	The young moult several times as it grows.	No	Yes
(3)	The young stop feeding during part of their life cycle.	Yes	Yes
(4)	The young live in water during part of their life cycle.	No	No

14. Which of the following pair of living things has a 4-stage life cycle?

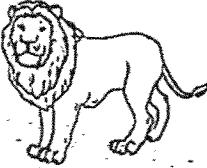
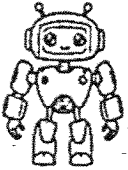
- (1) butterfly and mosquito
- (2) mosquito and cockroach
- (3) grasshopper and butterfly
- (4) grasshopper and cockroach

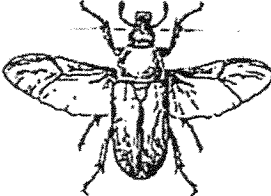
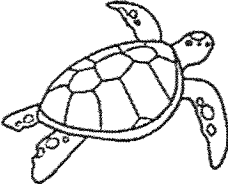
15. Study the following group of things.

Living things	Non-living things
 <p data-bbox="646 633 694 667">lion</p>	 <p data-bbox="976 638 1045 672">robot</p>
 <p data-bbox="625 936 705 969">parrot</p>	 <p data-bbox="965 940 1045 974">beetle</p>
 <p data-bbox="625 1227 694 1261">turtle</p>	 <p data-bbox="965 1232 1037 1265">cloud</p>

Which of the following has been grouped wrongly?

- (1) cloud
- (2) robot
- (3) parrot
- (4) beetle

16. Study the flow chart below.

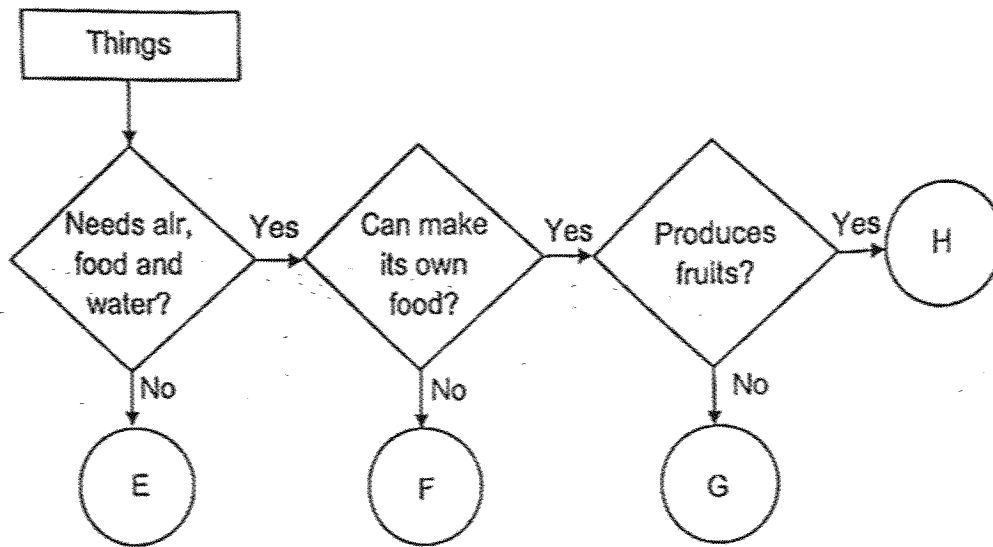

Which of the following best represents the thing X shown above?

- (1) E
- (2) F
- (3) G
- (4) H

17. The table shows how animals can be grouped.

	Gives birth	Lays eggs
Can swim	J	K
Cannot swim	L	M

The diagram shows an animal.

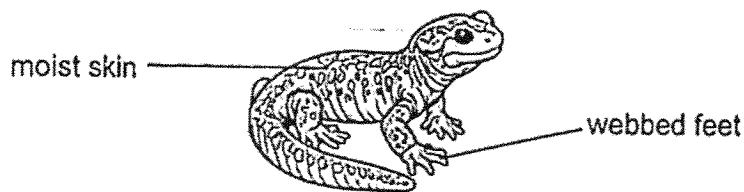

Which group does the above animal belong to?

- (1) J
 - (2) K
 - (3) L
 - (4) M
18. Study the table below.

Group N	Group P
duck	bat
frog	rabbit
cockroach	human being

The classification is based on _____.

- (1) how these animals breathe
- (2) how the animals reproduce
- (3) the movements of these animals
- (4) the types of body covering of these animals

19. Four students made the following statements as they observed the living things shown below.



Plant A

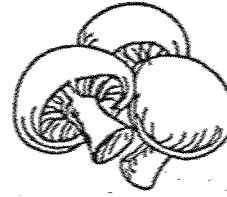

Mushroom

- Aria: Both are plants because they have stems.
Mike: Plant A is a flowering plant but mushroom is a non-flowering plant.
Tim: Plant A can make its own food while mushroom cannot.
Crystal: Both reproduce from spores.

Which student made the correct statement?

- (1) Aria
- (2) Mike
- (3) Tim
- (4) Crystal

20. Jenny used the following set-up to find out the flexibility of 4 strips of different materials, Q, R, S and T, of equal size.

She fixed one end of each strip of material on a tabletop and hung a weight on the other end. She measured the distance 'd' as shown in the diagram below.

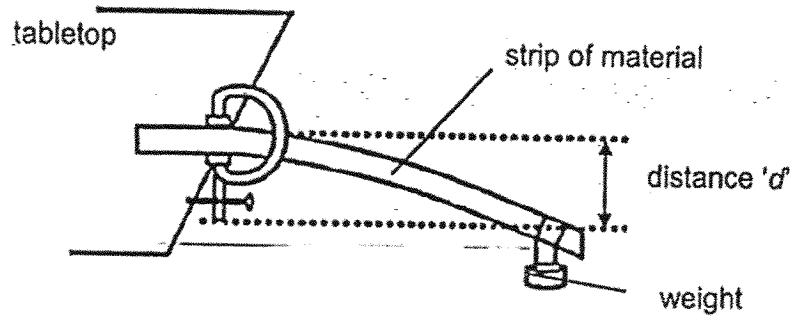

The table below shows the results of the experiment.

Material	d (cm)
Q	9
R	2
S	5
T	7

Which is the most flexible material?

- (1) Q
- (2) R
- (3) S
- (4) T

21. Strings W, X, Y and Z are made of different materials. The diagram below shows the greatest mass that each string can support before it breaks.

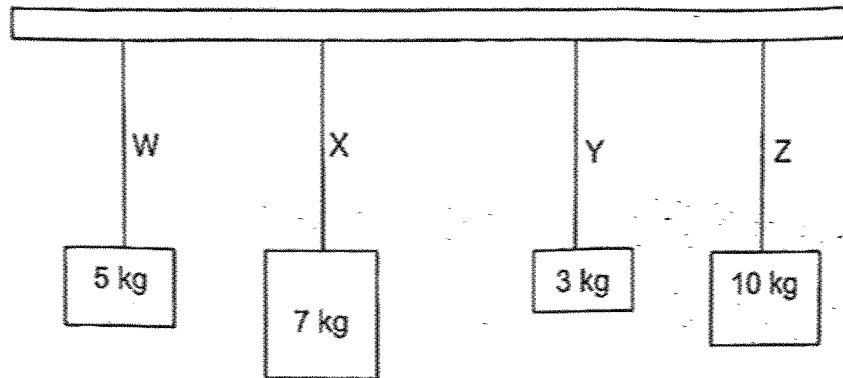

Which string(s) can support a mass of up to 6 kg without breaking?

- (1) Z only
- (2) W and Y only
- (3) X and Z only
- (4) W, X and Z only

22. A bar magnet was placed on a piece of styrofoam which floated on a basin of water. The compass was placed at position X. The top view of the set-up is shown in the diagram below.

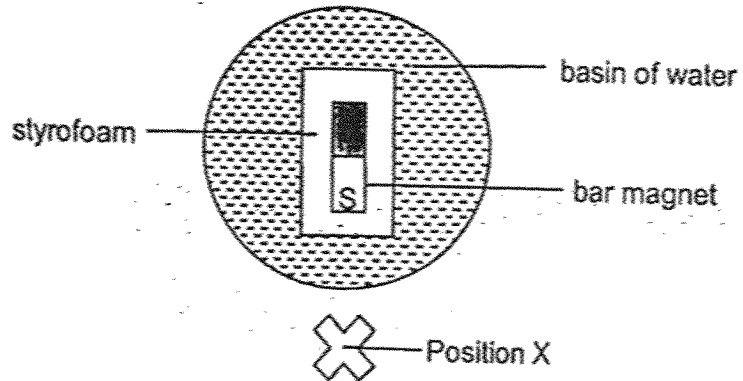

Which diagram shows the correct needle position on the compass when it was placed at position X?

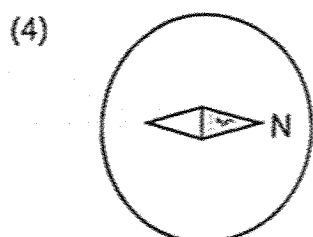
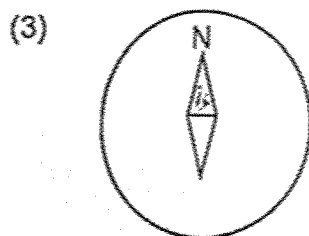
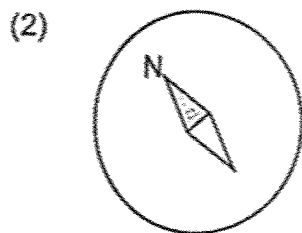
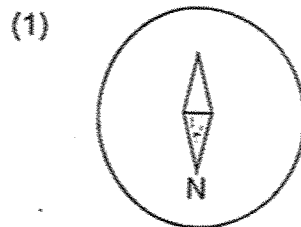

23. Four identical bar magnets were hung from the same height and equal distance apart from each other. The way they interacted is as shown below.

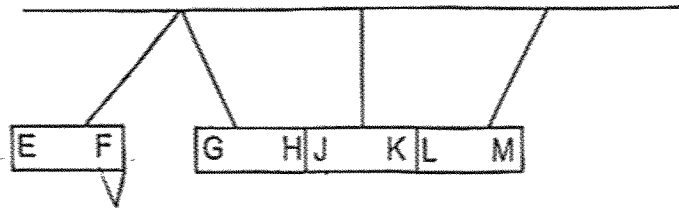

Which of the following shows a possible arrangement of the bar magnets?

- (1)
- (2)
- (3)
- (4)

24. The graph shows the number of days in each stage of Insect V's life cycle.

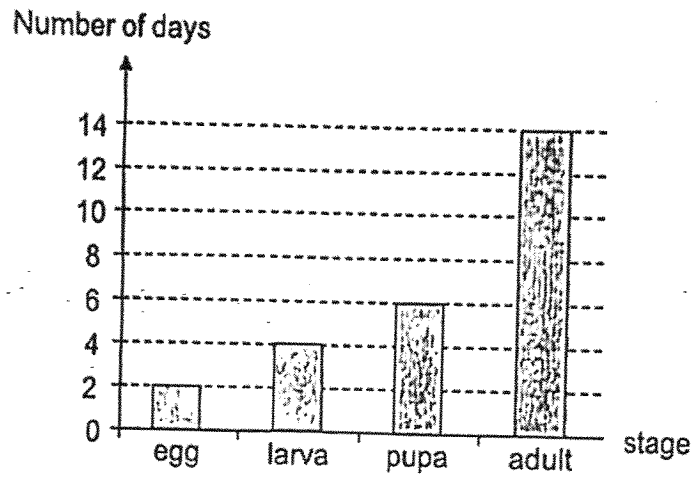

How many days does it take for insect V to become an adult from the time the eggs are laid?

- (1) 10
- (2) 12
- (3) 14
- (4) 26

END OF BOOKLET A

GO ON TO BOOKLET B



MAHA BODHI SCHOOL
2025 END OF YEAR EXAMINATION
PRIMARY THREE SCIENCE
(BOOKLET B)

Name: _____ ()

Class: Primary 3 _____

Date : 27 Oct 2025

Total Duration for Booklets A and B: 1 h 30 min

INSTRUCTIONS TO CANDIDATES:

1. Do not turn over this page until you are told to do so.
2. Follow all instructions carefully.
3. Answer all questions.
4. Write all your answer in this booklet.

Booklet	Marks Obtained	Max Marks
A		48
B		32
Total		80

Parent's signature: _____

BOOKLET B : [32 marks]

For questions 25 to 34, write your answers in this booklet.

The number of marks available is shown in the brackets [] at the end of each question or part-question.

25. A plant was placed in a well-lit area.

A cardboard box with an opening (not shown in diagram below) was placed over the plant. One week later, the leaves and stem grew in the following direction as shown below.

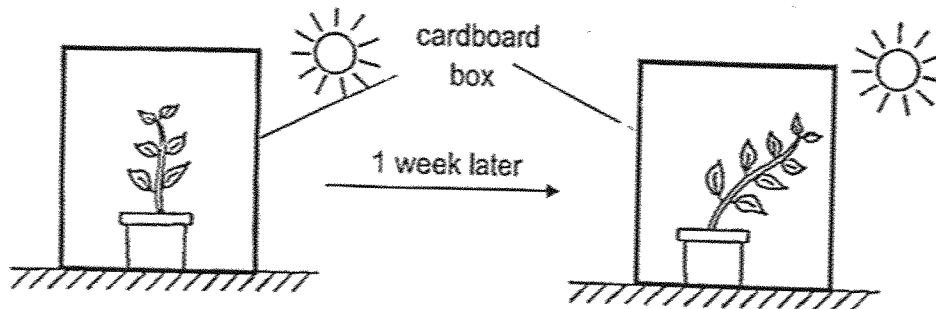

(a) Where was the opening of the cardboard box?
Place a tick (✓) in the box. [1]

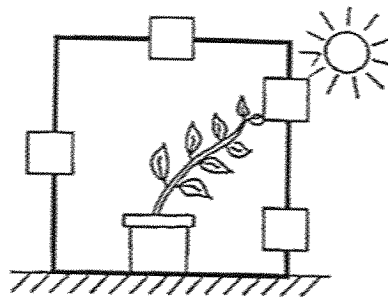

(b) Which characteristic of living things does the plant above show? [1]

Marks :

12

26. Observe the living things A, B, C and D below.

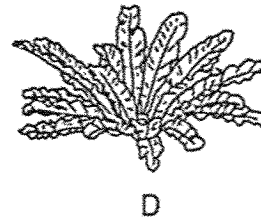
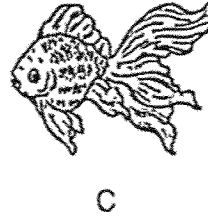
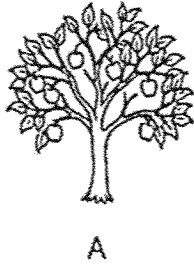

(a) Classify the living things A, B, C and D in the classification chart below. Write A, B, C and D in the correct box below. [2]

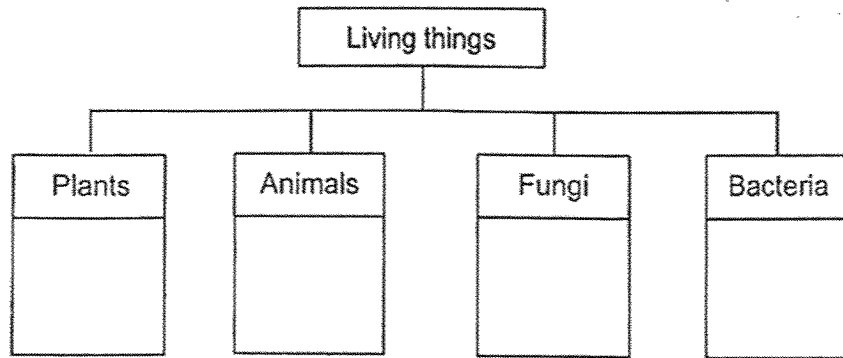

(b) Observe living things, A and D, above. State their methods of reproduction in the table below. [1]

Living thing	It reproduces by
A	
D	

(c) Observe the living thing E below.

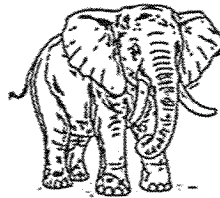

Based on the classification chart, which group of living things is living thing, E, is classified as? [1]

Marks : / 4

27. Study animal F and animal G below.



animal F

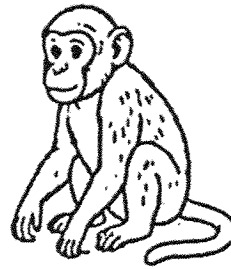

animal G

(a) State the type of body covering for animal F and G. [2]

	Type of body covering
animal F	
animal G	

(b) Observe animal H shown below.

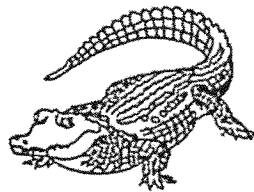

animal H

Based on the diagrams, state one similarity between animal H and animal F. [1]

Marks :

/ 3

28. Study the animals below.



bat



penguin

(a) (i) Identify the group of animals the bat belongs to. [1]

(ii) Based on the diagrams, bats are often mistaken for being in the same animal group as penguins. Give a reason why. [1]

(b) Study the flowchart below.

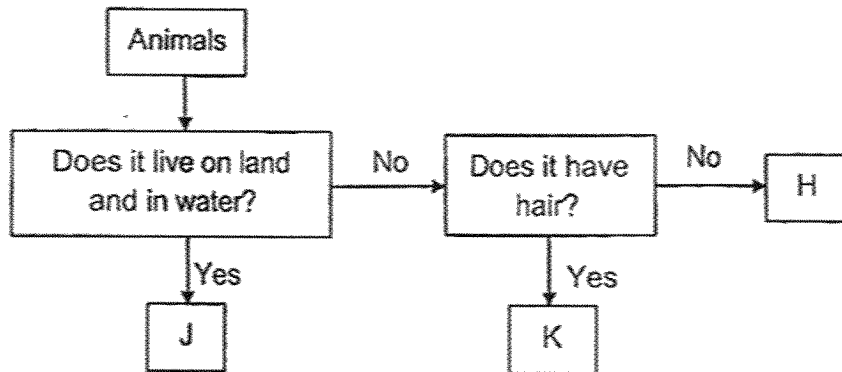

chicken

Based on the flow chart above, state which group, H, J or K, that the chicken belongs to. [1]

Marks : / 3

29. Joan had 2 slices of bread, L and M. She placed each bread inside a closed box. Bread L was toasted so water is removed from the bread before it was placed in a box.

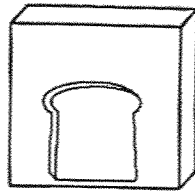

Bread L

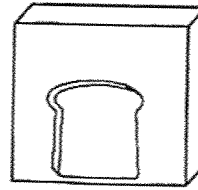

Bread M

One week later, she observed that some parts of Bread M had black patches on it but Bread L had no black patches.

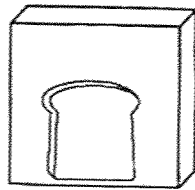

Bread L

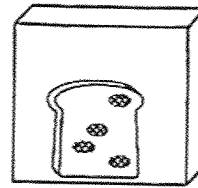

Bread M

- (a) Identify the black patches on Bread M. [1]

- (b) Explain why Bread L did not have the black patches growing on it. [2]

Marks :

13

30. Winnie wants to have a fish tank as shown below.

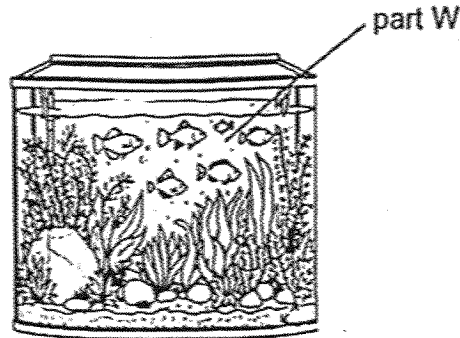

Winnie conducted an experiment shown below to find the best material to use to make part W for her to display her fishes for all to observe.

She used a torchlight and shone a light through three materials, P, Q and R as shown below.



She then recorded the amount of light that passed through the material in the bar graph shown below.

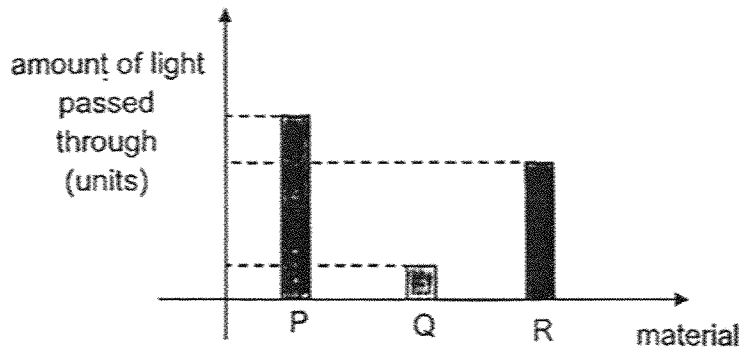

(a) Which material P, Q or R, is the most suitable to make Part W? [1]

(b) Give a reason for your answer in (a). [1]

Marks : 12

31. Lily hung three strips of materials, X, Y and Z, on a string and placed one end of the strips in a basin of coloured water as shown below.

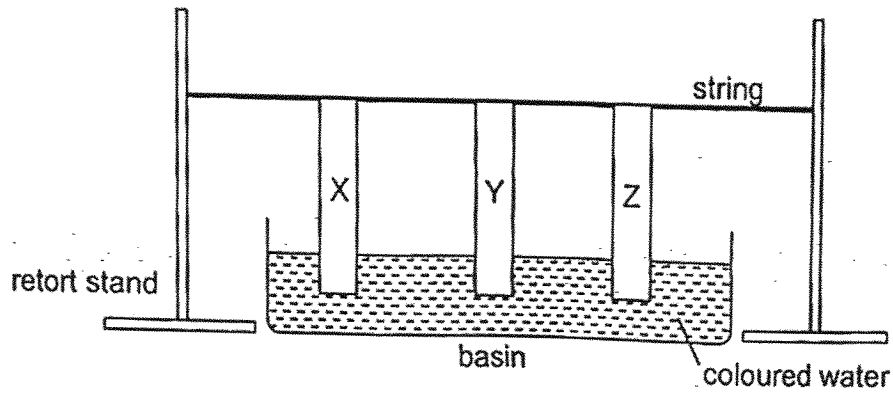

After some time, she took out the strips and measured the length of the strip that was stained in coloured water. The results were recorded in the table below.

	Material		
	X	Y	Z
Length of strip stained (cm)	2	5	0

- (a) State the property of material that is tested in this experiment. [1]

- (b) Based on the results, which material X, Y or Z, is most suitable to be used to make a raincoat? Explain your answer. [2]

Marks :

/ 3

32. Tara built a toy using the setup shown below.

When she connected the batteries to the electromagnet, Rod A moved and pushed the ball off the table.

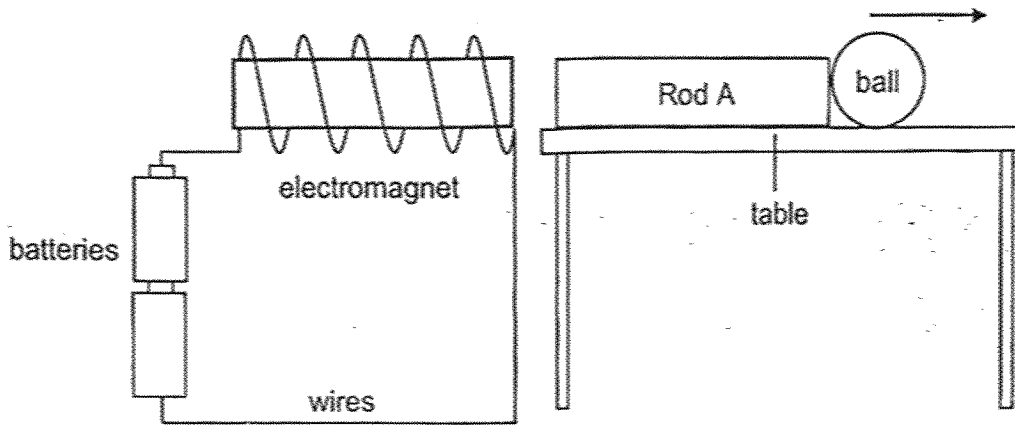

(a) Is rod A a magnetic object, non-magnetic object or a magnet? Explain your answer. [2]

(b) She removed one battery from the electromagnet. State how the distance travelled by the ball is affected by this change. [1]

The distance travelled by the ball _____.

(c) Give a reason for your answer in (b). [1]

Marks :

/ 4

33. Heidi carried out an investigation to compare the strength of 3 different types of magnets. She moved the magnet slowly towards the thumbtack and measured the distance at which the magnet first attracted the thumbtack.

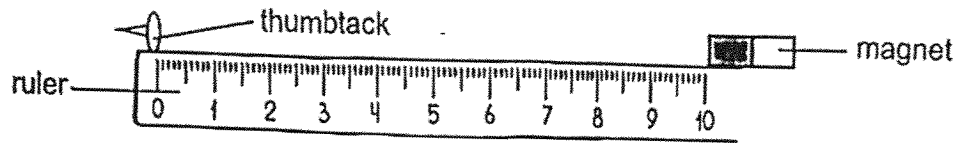

The distance (d) at which the magnets were able to attract the thumbtack are recorded on the table below.

	Distance, d (cm)
Bar magnet	5
Ring magnet	1
U-shaped magnet	2

- (a) Fill in the blanks below.

The _____ the magnet is, the _____ the distance the magnet is able to attract the thumbtack from. [1]

- (b) State the changed variable in Heidi's investigation. [1]

- (c) Heidi used a magnet to hold a few pieces of paper on the fridge door as shown below.

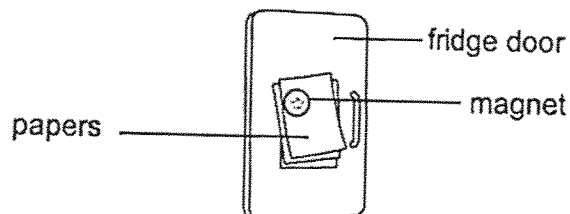

Based on the above results table, which magnet would allow her to hold the most number of papers on the fridge door? Explain your answer. [2]

Marks : / 4

34. (a) How many stages does a flowering plant have in its life cycle? [1]

The table below describes the life cycle of three animals, P, Q and R. A '✓' indicates that the characteristic is present in the life cycle of the animal while a 'x' indicates that the characteristic is absent.

Characteristics	P	Q	R
Young resembles the adult	✓	x	x
Has three stages in its life cycle	✓	x	✓

- (b) State a similarity between the life cycle of animal P and R. [1]

The picture below shows a frog.



- (c) Based on the characteristics stated in the table, which animal, P, Q or R, best represents a frog as shown above? Explain your answer. [2]

Marks :

/ 4

~ END OF PAPER ~

SCHOOL : MAHA BODHI PRIMARY SCHOOL
LEVEL : PRIMARY 3
SUBJECT : SCIENCE
TERM : 2025 END OF YEAR EXAMINATION

Q1	Q2	Q3	Q4	Q5	Q6	Q7	Q8	Q9	Q10
1	3	3	4	2	4	4	3	2	4
Q11	Q12	Q13	Q14	Q15	Q16	Q17	Q18	Q19	Q20
2	3	4	1	4	4	2	2	3	1
Q21	Q22	Q23	Q24						
3	3	2	2						

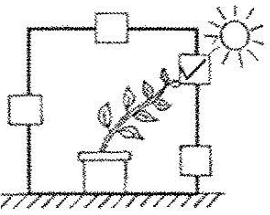
Q25	<p>a)</p>  <p>b) Living things respond to changes.</p>
Q26	<p>a) Plants – A, D Animals – B, C</p> <p>b) A – seed D – spore</p> <p>c) It is classified as an animal.</p>
Q27	<p>a) Scale Fur</p> <p>b) They both have a tail</p>
Q29	<p>a) (i) Mammal (ii) Both have wings</p> <p>b) H</p>
Q29	<p>a) The patches are called mould.</p> <p>b) Fungi/mould needs water to grow.</p>
Q30	<p>a) P</p> <p>b) Material P allows the most amount of light through it.</p>

Q31	a) Absorbency b) Material Z is waterproof and it did not absorb any water.
Q32	a) Rod A is magnetic as the electromagnet repelled it. b) Decreased c) It is not as strong as the one in the first setup.
Q33	a) Stronger – longest b) The type of magnet used c) Bar magnet – it can attract thumbtacks furthest away so it is the strongest
Q34	a) 3 b) Both have 3 stages in its life cycle c) P – the frog has 3 stages in its life cycle

www.sgexam.com