



NANYANG PRIMARY SCHOOL  
END-OF-YEAR EXAMINATION  
2025

**PRIMARY 4**  
**MATHEMATICS**  
**(BOOKLET A)**

Total Time for Booklets A and B: 1 hour 45 minutes

Additional materials: Optical Answer Sheet (OAS)

**INSTRUCTIONS TO CANDIDATES**

1. Write your name and index number in the space provided.
2. Do not turn over this page until you are told to do so.
3. Follow all instructions carefully.
4. Answer all questions.
5. Use a 2B pencil to shade your answers on the Optical Answer Sheet (OAS).

Name: \_\_\_\_\_ (      )

Class: Primary 4 (      )

This booklet consists of 9 printed pages and 1 blank page.

**BLANK PAGE**

Questions 1 to 15 carry 2 marks each. For each question, four options are given. One of them is the correct answer. Make your choice (1, 2, 3 or 4) and shade your answer on the Optical Answer Sheet. (30 marks)

---

1. The value of the digit 5 in 25 980 is \_\_\_\_\_.

- (1) 50 000
- (2) 5000
- (3) 500
- (4) 50

2. In which of the following are the numbers arranged from the smallest to the greatest?

- |     | (smallest) |       | (greatest) |
|-----|------------|-------|------------|
| (1) | 4891,      | 4819, | 4189       |
| (2) | 4189,      | 4891, | 4819       |
| (3) | 4891,      | 4189, | 4819       |
| (4) | 4189,      | 4819, | 4891       |

3. Which of the following is **not** a factor of 63?

- (1) 6
- (2) 7
- (3) 3
- (4) 9

4. The figure below is made up of identical triangles. What fraction of the figure is shaded?

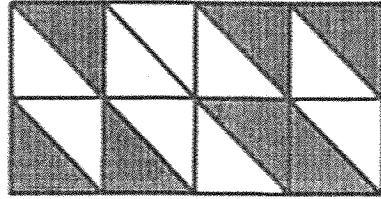

- (1)  $\frac{7}{9}$
- (2)  $\frac{7}{15}$
- (3)  $\frac{7}{16}$
- (4)  $\frac{9}{16}$
5. Express  $\frac{52}{100}$  as a decimal.

- (1) 0.52
- (2) 5.20
- (3) 0.052
- (4) 0.502

6. Which angle is greater than a right angle?

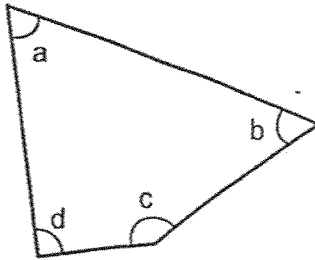

- (1)  $\angle a$
- (2)  $\angle b$
- (3)  $\angle c$
- (4)  $\angle d$

7. How many pairs of perpendicular lines are there in the figure below?

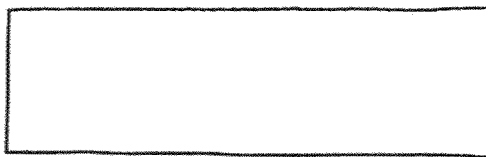

- (1) 1
- (2) 2
- (3) 3
- (4) 4

8. Which figure is a net of a cuboid?

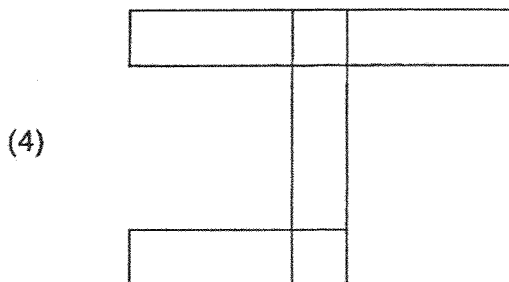
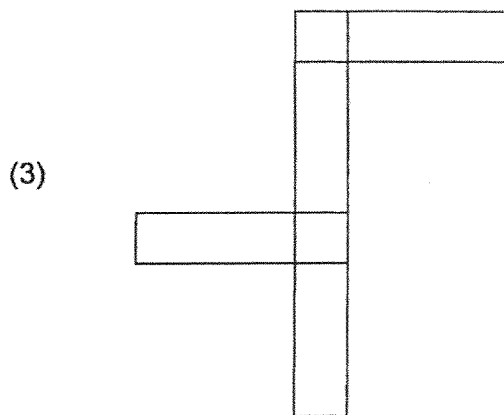
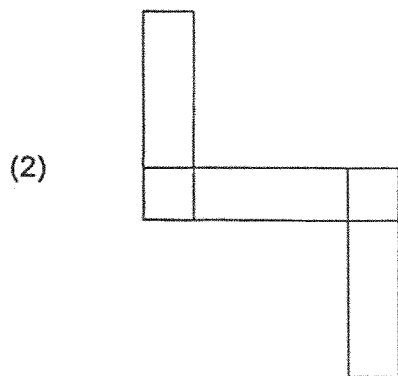
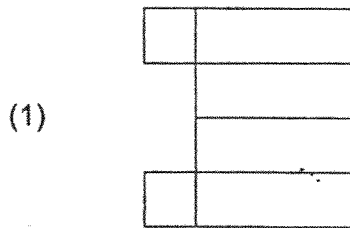

9. The perimeter of a square is 64 m. Find the length of the square.

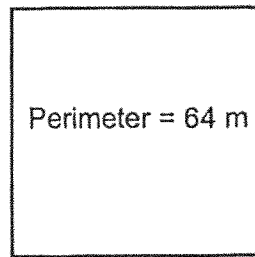

- (1) 8 m
- (2) 16 m
- (3) 32 m
- (4) 60 m

10. The figure below is made up of Square A with side 10 cm and Rectangle B with breadth 8 cm. Find the area of Rectangle B.

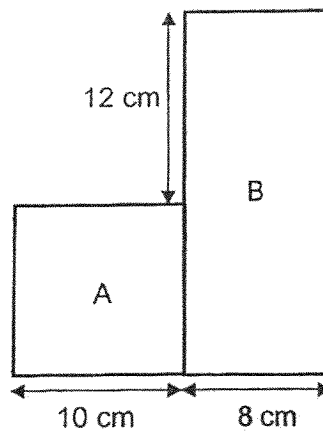

- (1) 176 cm<sup>2</sup>
- (2) 100 cm<sup>2</sup>
- (3) 96 cm<sup>2</sup>
- (4) 60 cm<sup>2</sup>

11. Use the table below to answer questions 11 and 12. The table shows the amount of money earned by 5 shops last week.

Shop	A	B	C	D	E
Amount earned (\$)	900	650	1000	800	650

Which of the following bar graphs best represents the data shown in the table above?

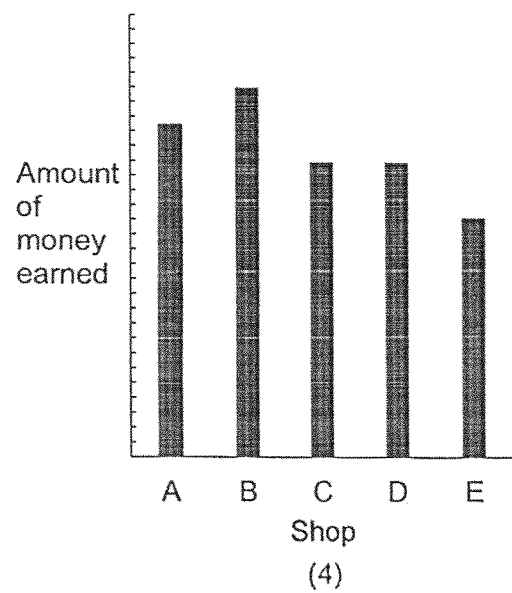
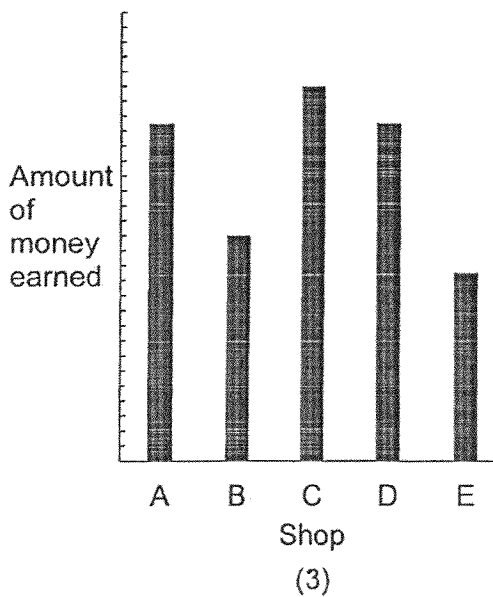
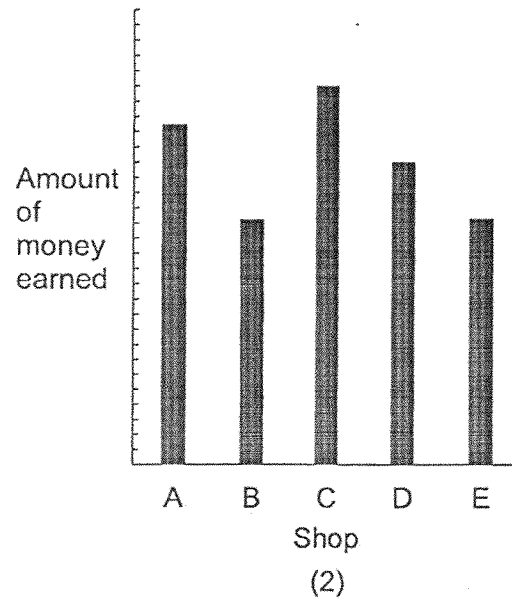
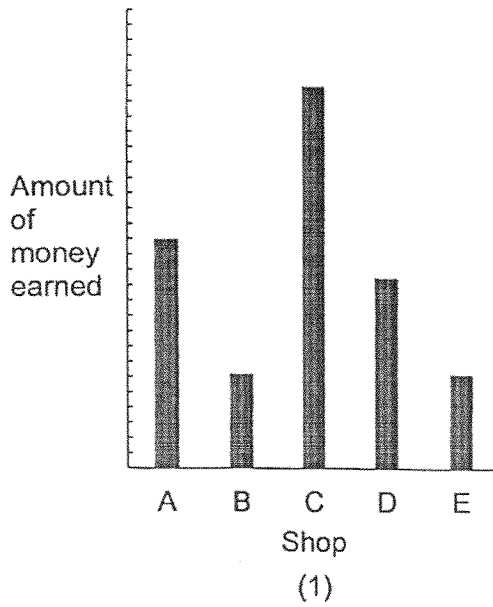

12. How much did Shop A, Shop B and Shop E earn in all?

- (1) \$2200
- (2) \$2550
- (3) \$3350
- (4) \$4000

13. The figure below is made of 6 identical squares. The area of each square is  $49 \text{ cm}^2$ . What is the perimeter of the figure?

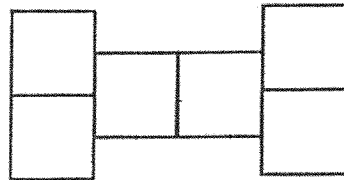

- (1) 42 cm
- (2) 84 cm
- (3) 96 cm
- (4) 98 cm

14. A number, when divided by 8, gives a quotient of 123 and a remainder of 5. What is the number?

- (1) 615
- (2) 979
- (3) 984
- (4) 989

15. The table below shows the prices of highlighters and pens sold in a shop in June and July.

Item	Price in June	Price in July
Highlighter	\$3.50	\$2.80
Pen	\$2.60	\$1.70

Meiling bought 6 highlighters and 4 pens in June. Nancy bought 6 highlighters and 4 pens in July. How much more money did Meiling spend than Nancy?

- (1) \$7.00
- (2) \$7.80
- (3) \$8.20
- (4) \$9.00



NANYANG PRIMARY SCHOOL  
END-OF-YEAR EXAMINATION  
2025

PRIMARY 4

MATHEMATICS  
(BOOKLET B)

Total Time for Booklets A and B: 1 hour 45 minutes

**INSTRUCTIONS TO CANDIDATES**

1. Write your name and index number in the space provided.
2. Do not turn over this page until you are told to do so.
3. Follow all instructions carefully.
4. Answer all questions.
5. Write your answers in this booklet.

Name: \_\_\_\_\_ (       )

Class: Primary 4 (       )

Parent's Signature: \_\_\_\_\_

Please sign and return the examination paper the next day. Any queries should be raised at the time when the paper is returned.

Booklet A	/ 30
Booklet B	/ 70
Total	/ 100

This booklet consists of 18 printed pages and 2 blank pages.

**BLANK PAGE**

Questions 16 to 35 carry 2 marks each. Show your working clearly and write your answers in the spaces provided. For questions which require units, give your answers in the units stated. (40 marks)

---

16. Subtract 386 from 954.

Ans: \_\_\_\_\_

---

17. Write  $3\frac{4}{5}$  as an improper fraction.

Ans: \_\_\_\_\_

---

18. What is the value of  $\frac{5}{8} + \frac{3}{4}$ ?

Express your answer as a mixed number.

Ans: \_\_\_\_\_

---

19. How many one-sixths are there in 1 whole?

Ans: \_\_\_\_\_

---

20. Arrange these numbers from the greatest to the smallest.

0.078 , 0.807 , 0.708

Ans: \_\_\_\_\_ , \_\_\_\_\_ , \_\_\_\_\_  
(greatest) (smallest)

---

21.  $0.4 = \frac{4}{\boxed{?}}$

What is the missing number in the box?

Ans: \_\_\_\_\_

---

22. Round 16.77 to the nearest whole number.

Ans: \_\_\_\_\_

---

23.  $8.87 - 6.54 =$  \_\_\_\_\_

Ans: \_\_\_\_\_

---

24. Measure and write down the size of  $\angle x$ .

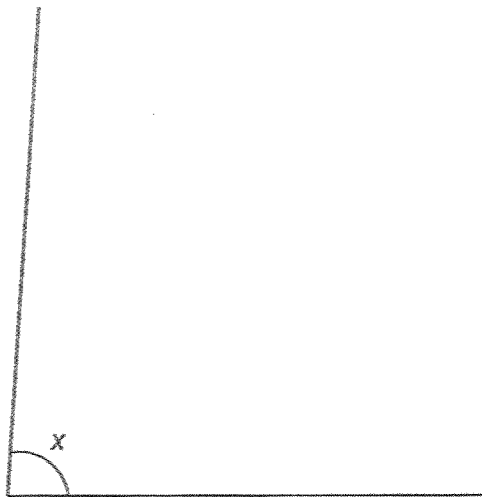

Ans: \_\_\_\_\_ °

---

25. WXYZ is a rectangle. Find  $\angle OXW$ .

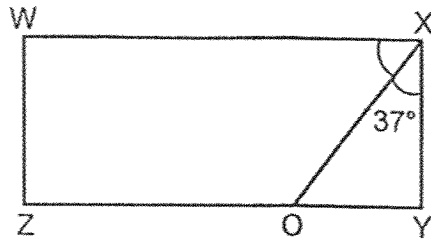

Ans: \_\_\_\_\_°

26. The table below shows the number of boys and girls in the school field and school hall during a recess. Complete the table.

	School Field	School Hall	Total
Boys	127	(a)	315
Girls	208	50	(b)

27. When a number is rounded to the nearest hundred, the answer is 1200.

(a) What is the smallest possible whole number?

Ans: (a) \_\_\_\_\_

(b) What is the greatest possible whole number?

Ans: (b) \_\_\_\_\_

---

28. Linus wanted to pack 1504 apples. Each box could contain 5 apples. What was the least number of boxes Linus needed to pack all the apples?

Ans: \_\_\_\_\_

---

29. Harif spent \$17.60 on a shirt. He spent \$4.85 more on the shirt than on a pair of shorts. How much did Harif spend altogether?

Ans: \$ \_\_\_\_\_

---

30. The figure below is made up of 2 identical squares and 4 identical rectangles. The length of a square is 4 times as long as the breadth of a rectangle. Find the total area of the 4 identical rectangles.

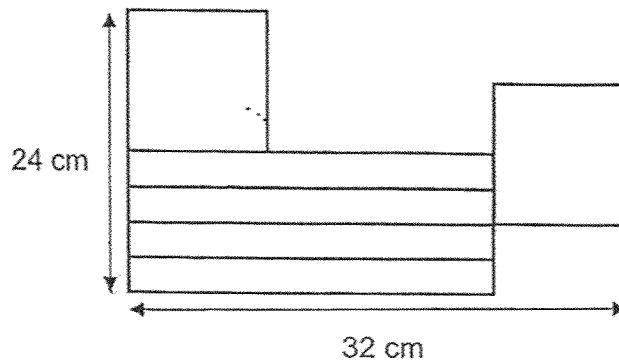

Ans: \_\_\_\_\_ cm<sup>2</sup>

31. Using a protractor and a ruler, draw  $\angle DEF = 118^\circ$ . Mark and label the angle. The line DE has been drawn for you.

\_\_\_\_\_

D E

32. Draw and label square ABCD on the square grid. One side of the square has been drawn for you.

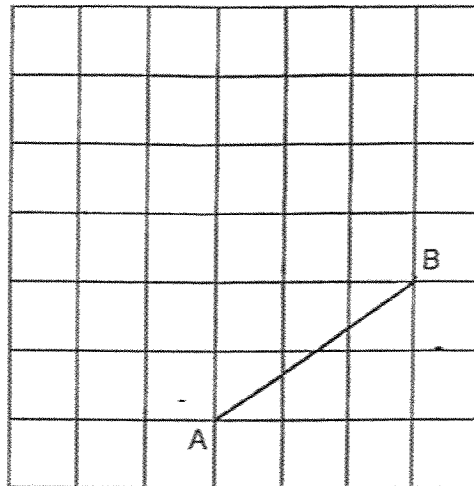

33. The dotted line MN is the line of symmetry. Complete the figure on the square grid below to make it symmetrical.

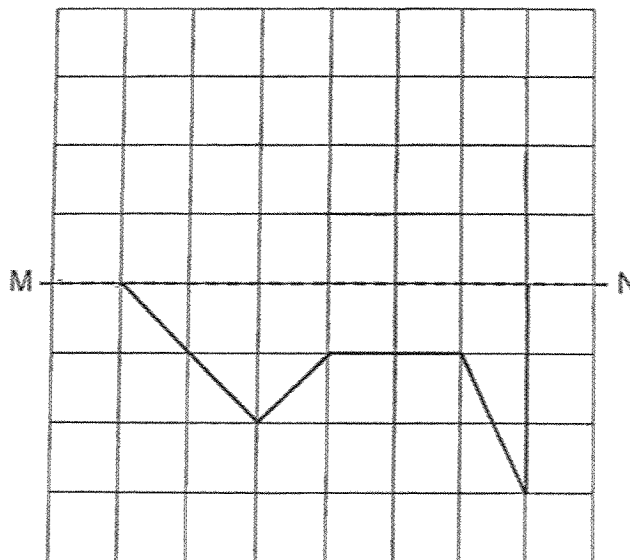

34. The pie chart represents a group of children's favourite ice cream flavour. Half of the children like chocolate flavour and vanilla flavour. There is an equal number of children who like strawberry flavour and vanilla flavour.

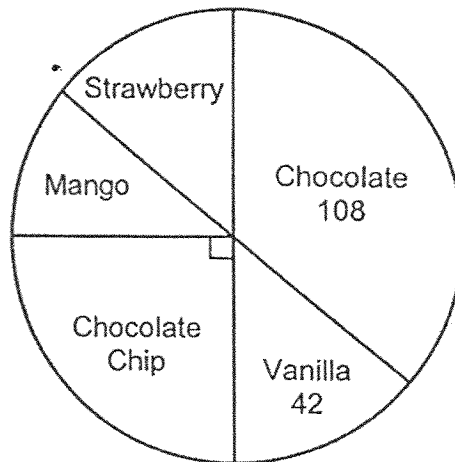

How many children like mango flavour?

Ans: \_\_\_\_\_

35. Jamilah drew a total of 30 squares and triangles. She drew a total of 108 sides. How many triangles did Jamilah draw?

Ans: \_\_\_\_\_

---

For questions 36 to 43, show your working clearly and write your answers in the spaces provided. The number of marks available is shown in brackets [ ] at the end of each question or part-question. (30 marks)

36. The line graph shows the number of buns sold. The data for years 2021 and 2022 shown on the graph was covered by some ink. The increase in number of buns sold from 2020 to 2021 is 4 times as many as the increase in the number of buns sold from 2019 to 2020. Find the number of buns sold in 2021.

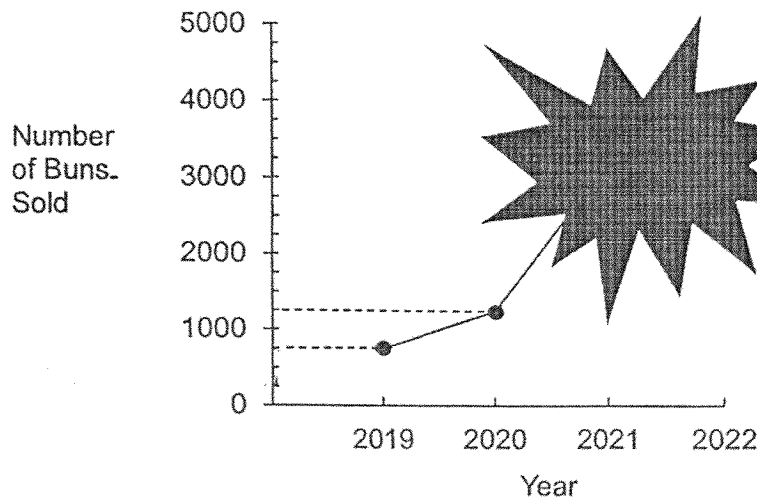

Ans: \_\_\_\_\_ [3]

37. The total mass of 5 chickens and 2 ducks is 12.6 kg. The mass of a duck is 2 times as much as the mass of a chicken.

(a) Find the mass of 1 chicken.

Ans: (a) \_\_\_\_\_ [2]

(b) Find the total mass of 1 chicken and 1 duck.

Ans: (b) \_\_\_\_\_ [1]

---

38. At a library, there were 7 times as many fiction books as non-fiction books. There were 3528 fiction books.

(a) How many more fiction books than non-fiction books were there at the library?

Ans: (a) \_\_\_\_\_ [2]

(b) How many books were there altogether in the library?

Ans: (b) \_\_\_\_\_ [2]

---

39. A field was built on a rectangular plot of land. The plot of land measured 24 m by 13 m. A 3-metre wide footpath was built around the field.

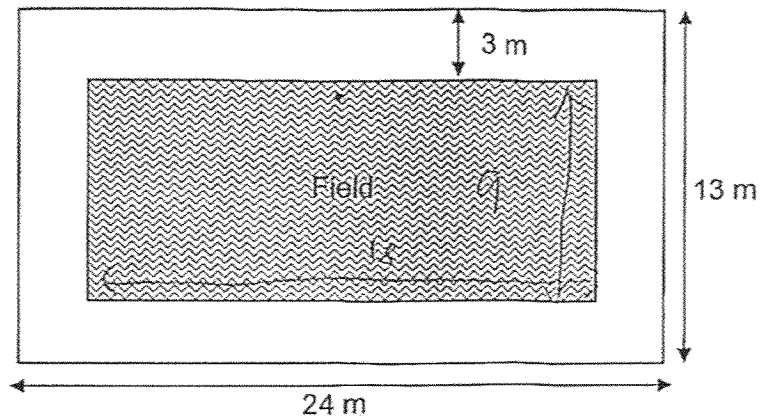

- (a) Find the area of the footpath.

Ans: (a) \_\_\_\_\_ [2]

- (b) Find the perimeter of the field.

Ans: (b) \_\_\_\_\_ [2]

40. The figure below is made up of two identical rectangles,  $ABIJ$  and  $EFGH$ , and a square  $CDHI$ .  $JHIG$  is a straight line.  $AB = CD = EF$ .

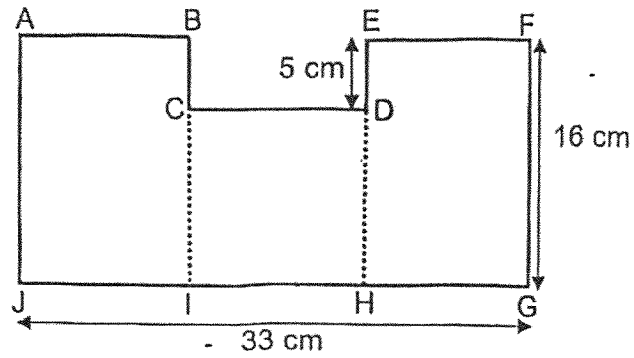

- (a) Find the area of the figure.

Ans: (a) \_\_\_\_\_ [2]

- (b) Find the perimeter of the figure.

Ans: (b) \_\_\_\_\_ [2]

41. There were 3 bottles of oil. All 3 bottles had the same amount of oil at first.  $\frac{1}{8}$  ℓ of oil was poured from bottle A to bottle B.  $\frac{1}{2}$  ℓ was then poured from bottle B to bottle C. There was  $\frac{5}{8}$  ℓ of oil in bottle B in the end.

(a) What was the total amount of oil in bottles A, B and C at first?

Ans: (a) \_\_\_\_\_ [3]

(b) Each litre of oil cost \$7.80. Find the cost of the total amount of oil in bottles A, B and C.

Ans: (b) \_\_\_\_\_ [1]

42. There were 540 more girls than boys in a school hall. After  $\frac{3}{4}$  of the girls and  $\frac{1}{2}$  of the boys exited the hall, there was an equal number of boys and girls who remained behind in the hall.

(a) Find the total number of boys and girls who exited the hall.

Ans: (a) \_\_\_\_\_ [2]

(b) Find the total number of boys and girls who were in the hall at first.

Ans: (b) \_\_\_\_\_ [2]

---

43. Lily baked 2425 more muffins than Jasmine at first. After Jasmine sold 1125 muffins, Lily had 6 times as many muffins as Jasmine in the end.

(a) How many muffins did Jasmine have in the end?

Ans: (a) \_\_\_\_\_ [2]

(b) How many muffins did Lily bake at first?

Ans: (b) \_\_\_\_\_ [2]

---

End of Paper

**BLANK PAGE**

**SCHOOL : NANYANG PRIMARY SCHOOL**  
**LEVEL : PRIMARY 4**  
**SUBJECT : MATHEMATICS**  
**TERM : 2025 END OF YEAR EXAMINATION**

Q1	Q2	Q3	Q4	Q5	Q6	Q7	Q8	Q9	Q10
2	4	1	3	1	3	2	3	2	1
Q11	Q12	Q13	Q14	Q15					
2	1	4	4	2					

www.sgexam.com

Questions 16 to 35 carry 2 marks each. Show your working clearly and write your answers in the spaces provided. For questions which require units, give your answers in the units stated. (40 marks)

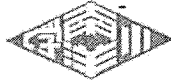

NANYANG PRIMARY SCHOOL  
END-OF-YEAR EXAMINATION  
2025

PRIMARY 4

MATHEMATICS  
(BOOKLET B)

Total Time for Booklets A and B: 1 hour 45 minutes

**INSTRUCTIONS TO CANDIDATES**

1. Write your name and index number in the space provided.
2. Do not turn over this page until you are told to do so.
3. Follow all instructions carefully.
4. Answer all questions.
5. Write your answers in this booklet.

Name: \_\_\_\_\_ ( )

Class: Primary 4 ( )

Parent's Signature: \_\_\_\_\_

Use sign and return the examination paper the next day. Any queries should be raised at the time when the paper is returned.

Booklet A	/ 30
Booklet B	/ 70
<b>Total</b>	<b>/ 100</b>

This booklet consists of 18 printed pages and 2 blank pages.

16. Subtract 386 from 954.

$$\begin{array}{r} 954 \\ - 386 \\ \hline 568 \end{array}$$

Ans: 568

17. Write  $3\frac{4}{5}$  as an improper fraction.

$$\begin{aligned} 3\frac{4}{5} &= 3 + \frac{4}{5} \\ &= \frac{15}{5} + \frac{4}{5} \\ &= \frac{19}{5} \end{aligned}$$

Ans:  $\frac{19}{5}$

18. What is the value of  $\frac{5}{8} + \frac{3}{4}$ ?

Express your answer as a mixed number.

$$\begin{aligned} \frac{5}{8} + \frac{3 \times 2}{4 \times 2} &= \frac{5}{8} + \frac{6}{8} \\ &= \frac{11}{8} \\ &= 1\frac{3}{8} \end{aligned}$$

Ans:  $1\frac{3}{8}$

19. How many one-sixths are there in 1 whole?

$$1 = \frac{6}{6}$$

Ans: 6

20. Arrange these numbers from the greatest to the smallest.

0.078 , 0.807 , 0.708

Ans: 0.807 (greatest)      0.708      0.078 (smallest)

21.  $0.4 = \frac{4}{\boxed{?}}$

What is the missing number in the box?

Ans: 10

22. Round 16.77 to the nearest whole number.

$$16.77 \approx 17 \text{ (Round up)}$$

Ans: 17

23.  $8.87 - 6.54 =$  \_\_\_\_\_

$$\begin{array}{r} 8.87 \\ - 6.54 \\ \hline 2.33 \end{array}$$

Ans: 2.33

24. Measure and write down the size of  $\angle x$ .

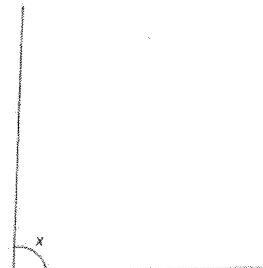

Ans: 87

25. WXYZ is a rectangle. Find  $\angle OXW$ .

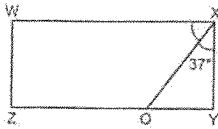

$$90^\circ - 37^\circ = 53^\circ$$

Ans: 53

26. The table below shows the number of boys and girls in the school field and school hall during a recess. Complete the table.

	School Field	School Hall	Total
Boys	127	(a) 188	315
Girls	208	50	(b) 258

Boys

$$\begin{array}{r} 2810 \\ - 127 \\ \hline 188 \end{array}$$

Girls (Total)

$$\begin{array}{r} 208 \\ + 50 \\ \hline 258 \end{array}$$

30. The figure below is made up of 2 identical squares and 4 identical rectangles. The length of a square is 4 times as long as the breadth of a rectangle. Find the total area of the 4 identical rectangles.

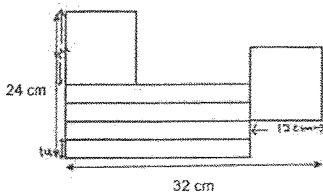

8 units  $\rightarrow$  24 cm

1 unit  $\rightarrow$   $24 \div 8 = 3$  cm

4 units  $\rightarrow$   $3 \times 4 = 12$  cm

Length of rectangle  $\rightarrow$   $32 - 12 = 20$  cm

Area of 1 rectangle  $\rightarrow$   $20 \times 3 = 60 \text{ cm}^2$

Area of 4 rectangles  $\rightarrow$   $60 \times 4 = 240 \text{ cm}^2$

Ans: 240  $\text{cm}^2$

31. Using a protractor and a ruler, draw  $\angle DEF = 118^\circ$ . Mark and label the angle. The line DE has been drawn for you.

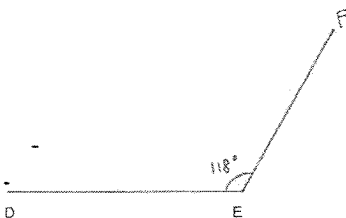

27. When a number is rounded to the nearest hundred, the answer is 1200.

- (a) What is the smallest possible whole number?

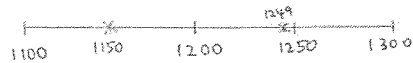

Ans: (a) 1150

- (b) What is the greatest possible whole number?

Ans: (b) 1249

28. Linus wanted to pack 1504 apples. Each box could contain 5 apples. What was the least number of boxes Linus needed to pack all the apples?

$$\begin{array}{r} 300 \text{ (R4)} \\ 5 \overline{)1504} \\ \underline{15} \phantom{0} \\ 0 \phantom{0} \\ \underline{0} \phantom{0} \\ 4 \phantom{0} \\ \underline{4} \\ 0 \end{array}$$

$$300 + 1 = 301$$

Ans: 301

29. Harif spent \$17.60 on a shirt. He spent \$4.85 more on the shirt than on a pair of shorts. How much did Harif spend altogether?

$$\$17.60 - \$4.85 = \$12.75 \text{ (shorts)}$$

$$\$17.60 + \$12.75 = \$30.35 \text{ (total)}$$

Ans: \$ 30.35

32. Draw and label square ABCD on the square grid. One side of the square has been drawn for you.

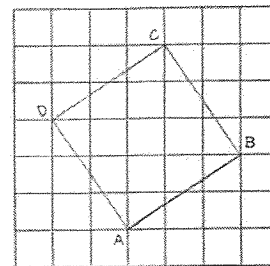

33. The dotted line MN is the line of symmetry. Complete the figure on the square grid below to make it symmetrical.

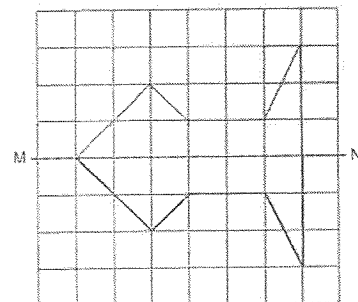

34. The pie chart represents a group of children's favourite ice cream flavour. Half of the children like chocolate flavour and vanilla flavour. There is an equal number of children who like strawberry flavour and vanilla flavour.

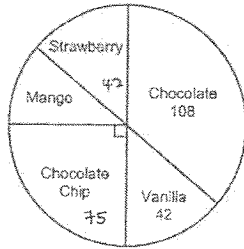

How many children like mango flavour?

Choc and Vanilla  $\rightarrow 108 + 42 = 150$

Choc chip  $\rightarrow 150 \div 2 = 75$

Mango  $\rightarrow 150 - 42 - 75 = 33$

OR

$75 - 42 = 33$

Ans: 33

10

For questions 36 to 43, show your working clearly and write your answers in the spaces provided. The number of marks available is shown in brackets [ ] at the end of each question or part-question. (30 marks)

36. The line graph shows the number of buns sold. The data for years 2021 and 2022 shown on the graph was covered by some ink. The increase in number of buns sold from 2020 to 2021 is 4 times as many as the increase in the number of buns sold from 2019 to 2020. Find the number of buns sold in 2021.

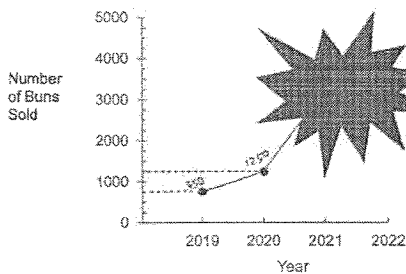

Increase from 2019 to 2020  $\rightarrow 1250 - 750 = 500$

Increase from 2020 to 2021  $\rightarrow 500 \times 4 = 2000$

$2000 + 1250 = 3250$

Ans: 3250 [3]

12

35. Jamilah drew a total of 30 squares and triangles. She drew a total of 108 sides. How many triangles did Jamilah draw?

Method 1: Guess and Check

No. of squares	No. of sides ( $\square$ )	No. of triangles	No. of sides ( $\triangle$ )	Total no. of sq. & triangles	Total no. of sides
15	$15 \times 4 = 60$	15	$15 \times 3 = 45$	$15 + 15 = 30$	$60 + 45 = 105$
16	$16 \times 4 = 64$	14	$14 \times 3 = 42$	$16 + 14 = 30$	$64 + 42 = 106$
18	$18 \times 4 = 72$	(12)	$12 \times 3 = 36$	$18 + 12 = 30$	$72 + 36 = 108$

Method 2: Supposition

Suppose all are squares,

$30 \times 4 = 120$

$120 - 108 = 12$

$4 - 3 = 1$

$12 \div 1 = 12$

Ans: 12

11

37. The total mass of 5 chickens and 2 ducks is 12.6 kg. The mass of a duck is 2 times as much as the mass of a chicken.

(a) Find the mass of 1 chicken.

9 units  $\rightarrow 12.6$  kg

1 unit  $\rightarrow 12.6 \div 9 = 1.4$

$$\begin{array}{r} 1.4 \\ 9 \overline{) 12.6} \\ \underline{-9} \phantom{0} \\ 36 \\ \underline{-36} \\ 0 \end{array}$$

Ans: (a) 1.4 kg [2]

(b) Find the total mass of 1 chicken and 1 duck.

Mass of 1 duck  $\rightarrow 1.4 \times 2 = 2.8$

Mass of 1 chicken and 1 duck  $\rightarrow 2.8 + 1.4 = 4.2$

Ans: (b) 4.2 kg [1]

13

38. At a library, there were 7 times as many fiction books as non-fiction books. There were 3528 fiction books.

(a) How many more fiction books than non-fiction books were there at the library?

(a) ?

$$\begin{array}{r} 504 \\ 7 \overline{) 3528} \\ \underline{35} \phantom{0} \\ 0 \phantom{0} \\ \underline{0} \phantom{0} \\ 0 \phantom{0} \\ \underline{0} \phantom{0} \\ 0 \phantom{0} \\ \underline{0} \phantom{0} \\ 0 \phantom{0} \end{array}$$

7 units  $\rightarrow 3528$   
 1 unit  $\rightarrow 3528 \div 7 = 504$   
 6 units  $\rightarrow 504 \times 6 = 3024$

Ans: (a) 3024 [2]

(b) How many books were there altogether in the library?

1 unit  $\rightarrow 504$   
 8 units  $\rightarrow 504 \times 8 = 4032$

$$\begin{array}{r} 504 \\ \times 8 \\ \hline 4032 \end{array}$$

Ans: (b) 4032 [2]

14

40. The figure below is made up of two identical rectangles, ABJI and EFGH, and a square CDHI. JHNG is a straight line.  $AB = CD = EF$ .

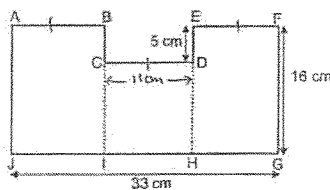

(a) Find the area of the figure.

$$33 \div 3 = 11$$

$$\text{Area of BCDE} \rightarrow 11 \times 5 = 55$$

$$33 \times 16 = 528$$

$$528 - 55 = 473$$

$$\begin{array}{r} 1 \\ 33 \\ \times 16 \\ \hline 198 \\ + 330 \\ \hline 528 \end{array}$$

Ans: (a) 473 cm<sup>2</sup> [2]

(b) Find the perimeter of the figure.

$$33 + 16 + 33 + 16 + 5 + 5 = 108 \text{ cm}$$

Ans: (b) 108 cm [2]

16

39. A field was built on a rectangular plot of land. The plot of land measured 24 m by 13 m. A 3-metre wide footpath was built around the field.

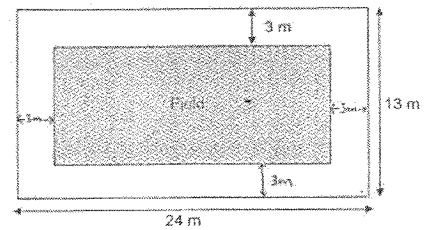

(a) Find the area of the footpath.

Area of rectangular land  $\rightarrow 24 \times 13 = 312$

Length of field  $\rightarrow 24 - 3 - 3 = 18$

Breadth of field  $\rightarrow 13 - 3 - 3 = 7$

Area of field  $\rightarrow 18 \times 7 = 126$

Area of the footpath  $\rightarrow 312 - 126 = 186$

Ans: (a) 186 m<sup>2</sup> [2]

(b) Find the perimeter of the field.

$$18 + 7 + 18 + 7 = 50$$

Ans: (b) 50 m [2]

15

41. There were 3 bottles of oil. All 3 bottles had the same amount of oil at first.  $\frac{1}{8}$  t of oil was poured from bottle A to bottle B.  $\frac{1}{2}$  t was then poured from bottle B to bottle C. There was  $\frac{5}{8}$  t of oil in bottle B in the end.

(a) What was the total amount of oil in bottles A, B and C at first?

$$\frac{5}{8} + \frac{1 \times 4}{2 \times 4} = \frac{5}{8} + \frac{4}{8}$$

$$= \frac{9}{8}$$

$$\frac{9}{8} - \frac{1}{8} = \frac{8}{8} = 1$$

$$1 \times 3 = 3$$

Ans: (a) 3 t [3]

(b) Each litre of oil cost \$7.80. Find the cost of the total amount of oil in bottles A, B and C.

$$\$7.80 \times 3 = \$23.40$$

$$\begin{array}{r} 27.80 \\ \times 3 \\ \hline 23.40 \end{array}$$

Ans: (b) \$23.40 [1]

17

42. There were 540 more girls than boys in a school hall. After  $\frac{3}{4}$  of the girls and  $\frac{1}{2}$  of the boys exited the hall, there was an equal number of boys and girls who remained behind in the hall.

(a) Find the total number of boys and girls who exited the hall.

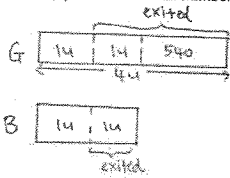

2 units  $\rightarrow$  540  
 1 unit  $\rightarrow$   $540 \div 2 = 270$   
 4 units  $\rightarrow$   $270 \times 4 = 1080$

Ans: (a) 1080 [2]

(b) Find the total number of boys and girls who were in the hall at first.

1 unit  $\rightarrow$  270  
 6 units  $\rightarrow$   $270 \times 6 = 1620$

Ans: (b) 1620 [2]

43. Lily baked 2425 more muffins than Jasmine at first. After Jasmine sold 1125 muffins, Lily had 6 times as many muffins as Jasmine in the end.

(a) How many muffins did Jasmine have in the end?

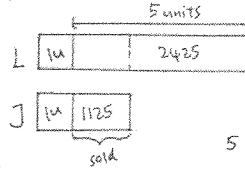

5 units  $\rightarrow$   $2425 + 1125$   
 $= 3550$   
 1 unit  $\rightarrow$   $3550 \div 5 = 710$

Ans: (a) 710 [2]

(b) How many muffins did Lily bake at first?

1 unit  $\rightarrow$  710  
 6 units  $\rightarrow$   $710 \times 6 = 4260$

Ans: (b) 4260 [2]

End of Paper