



CATHOLIC HIGH SCHOOL
END-OF-YEAR EXAMINATION 2025
PRIMARY FOUR
- SCIENCE
BOOKLET A

Name: _____ ()

Class: Primary 4 - _____

Date: 30 October 2025

30 questions

60 marks

Total Time for Booklets A and B: 1 hour 30 minutes

INSTRUCTIONS TO CANDIDATES

Do not turn over this page until you are told to do so.

Follow all instructions carefully.

Answer all questions.

Shade your answers in the Optical Answer Sheet (OAS) provided.

This booklet consists of 21 printed pages, excluding the cover page.

For each question from 1 to 30, four options are given. One of them is the correct answer. Make your choice (1, 2, 3 or 4). Shade your answer on the Optical Answer Sheet. (60 marks)

- 1 Jenson found a plant in the garden and measured its height. After two weeks, he measured its height again.

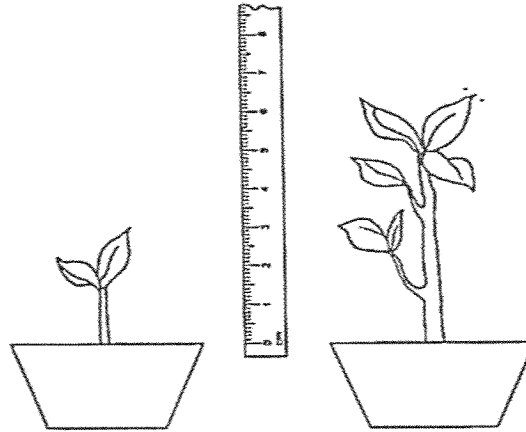

From his observation, Jenson concluded that the plant is a living thing because it can _____.

- (1) grow
- (2) breathe
- (3) respond
- (4) reproduce

2 The diagram shows how some living things can be grouped.

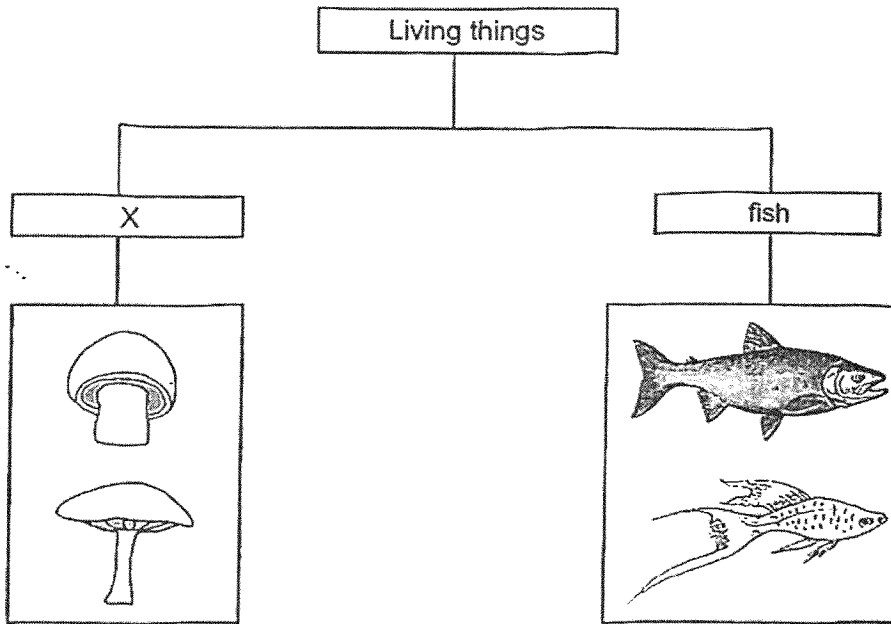

Which of the following is the most suitable heading for group X?

- (1) fungi
- (2) insects
- (3) bacteria
- (4) mammals

3 The diagram shows an axe.

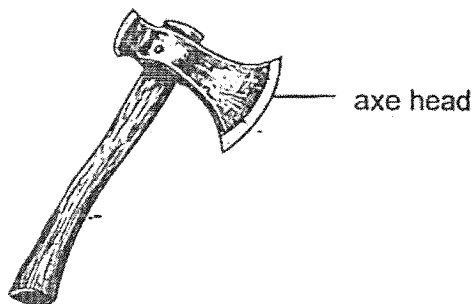

Metal is used to make the axe head because metal _____.

- (1) can reflect light
- (2) does not break easily
- (3) can bend without breaking
- (4) does not allow light to pass through

4 The diagram shows the life cycle of a plant.

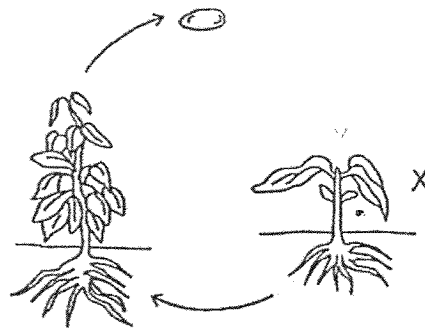

What is the stage marked X?

- (1) egg
- (2) seed
- (3) adult plant
- (4) young plant

5 A, B, C and D are the various stages in the life cycle of a mosquito.

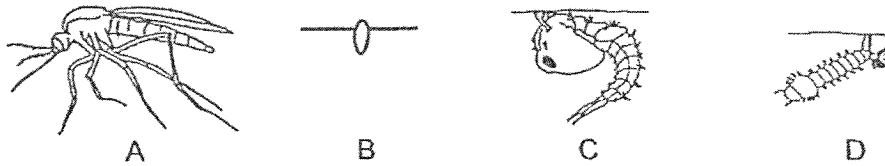

Which of the following correctly shows the life cycle of a mosquito?

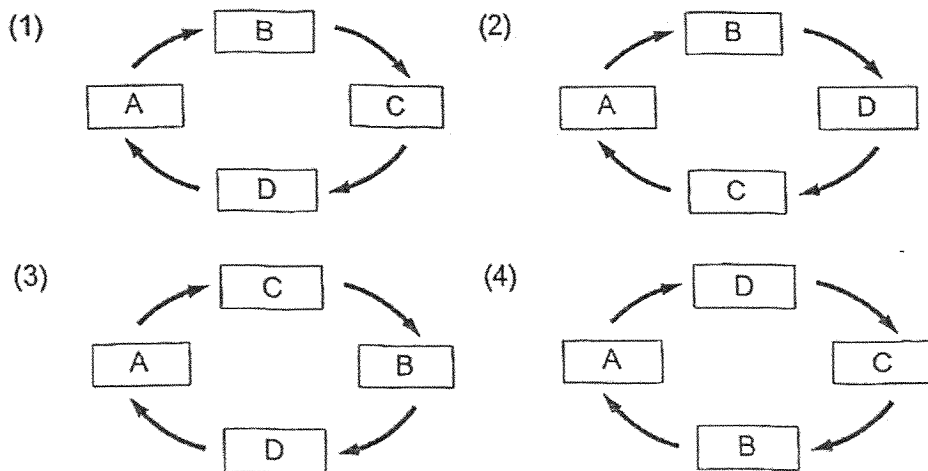

6 The diagram shows a magnet brought near a plastic block.



What will happen to the plastic block? It will _____.

- (1) move up
- (2) not move
- (3) move to the left
- (4) move to the right

7 Study the diagram.

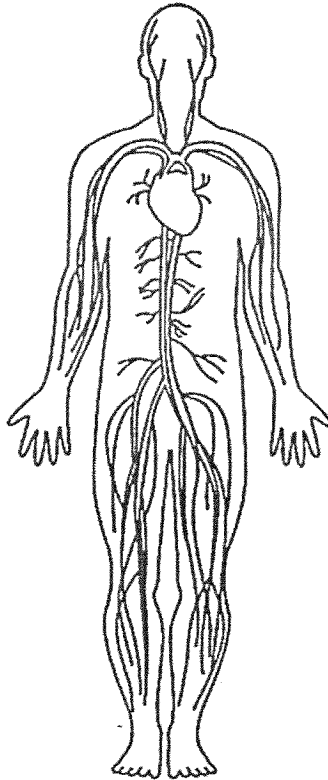

Which human system is shown above?

- (1) skeletal system
- (2) muscular system
- (3) circulatory system
- (4) respiratory system

8 Study the diagram.

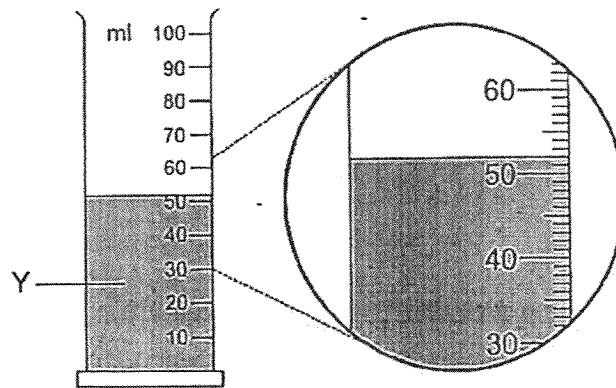

What is the volume of liquid Y?

- (1) 50 ml
 - (2) 52 ml
 - (3) 62 ml
 - (4) 68 ml
- 9 Which substance has a fixed shape?
- (1) air
 - (2) oil
 - (3) water
 - (4) paper

10 The set-up shows a torch shining on a metal ball.

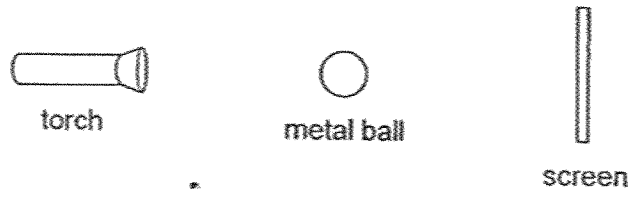

Which of the following would likely be seen on the screen?

(1)

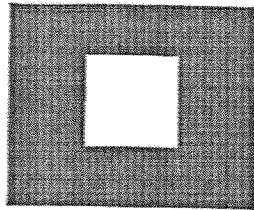

(2)

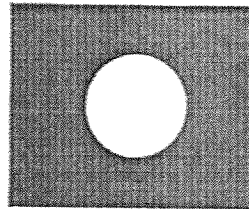

(3)

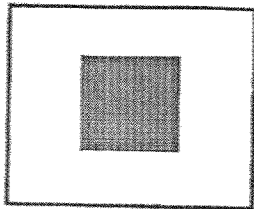

(4)

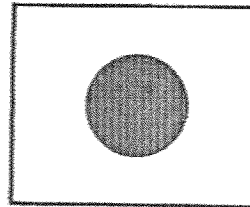

11 Study the diagram.

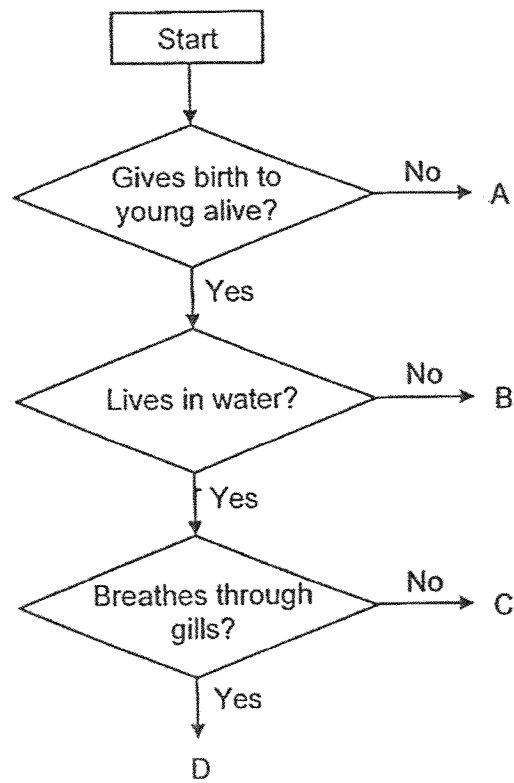

Animal S is a mammal that lives in the sea. Which letter, A, B, C or D, best represents animal S?

- (1) A
- (2) B
- (3) C
- (4) D

12 Janice puts on her swimming goggles before she goes for a swim.

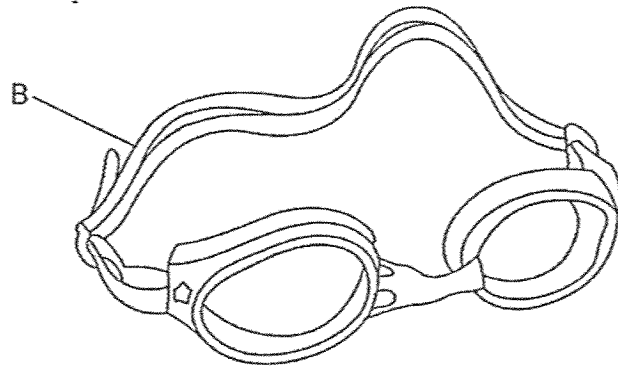

Based on the properties shown, which material is most suitable for making part B of the goggles? A tick (✓) shows that the material has that property.

	Material	Property	
		Flexible	Waterproof
(1)	P	x	x
(2)	Q	x	
(3)	R		
(4)	S		x

13 Two trees, A and B, were grown and the number of leaves on each was recorded at different stages of their growth.

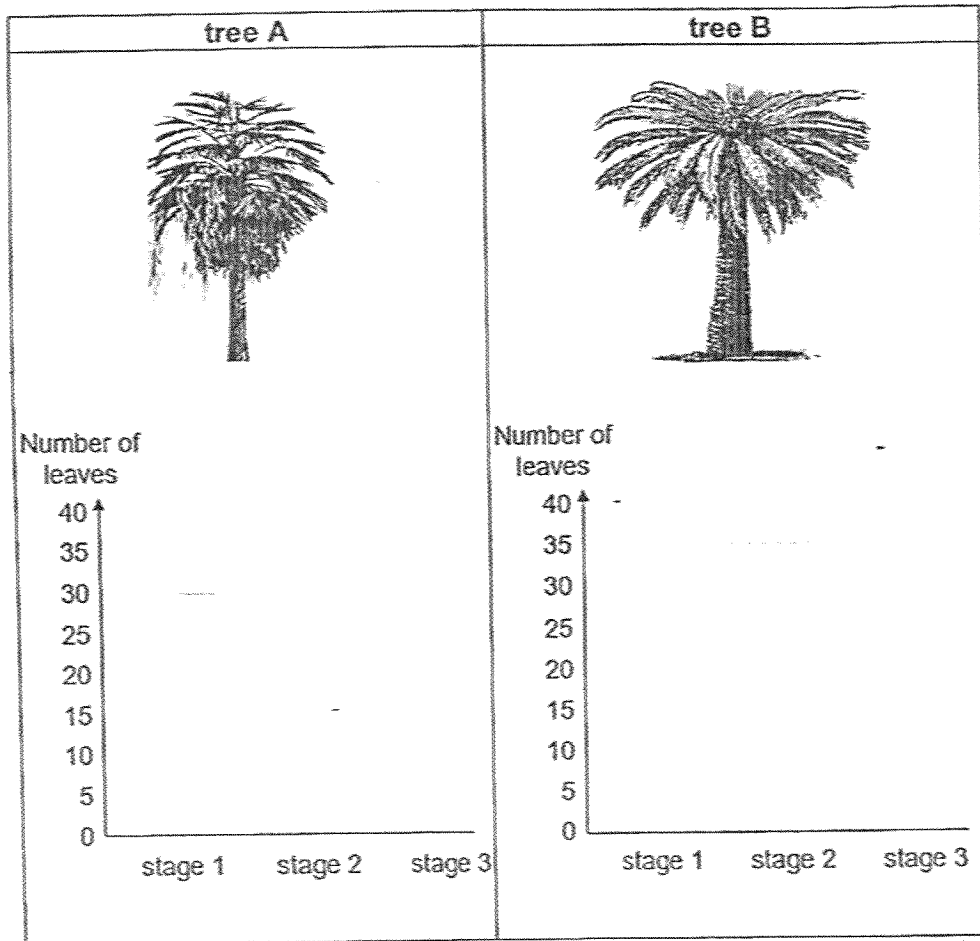

What conclusions can be made from the results?

- A Tree A has a longer stage 1 than tree B.
- B Tree A is taller than tree B at stages 2 and 3.
- C Tree B has fewer leaves than tree A at stage 3.
- D Tree B has fewer leaves than tree A at stage 2.

- (1) A and B only
- (2) C and D only
- (3) A, B and D only
- (4) B, C and D only

- 14 The diagram shows how a steel bar AB was magnetised using the Stroke method as shown in diagram 1. Diagram 2 shows the poles of bar AB after it was magnetised.

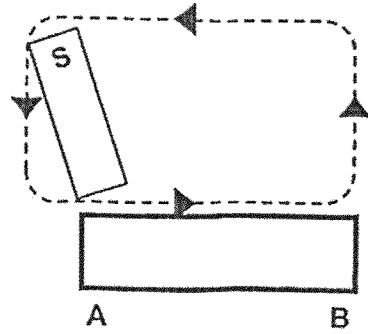

diagram 1



diagram 2

Another steel bar XY was magnetised using two magnets as shown in diagram 3.

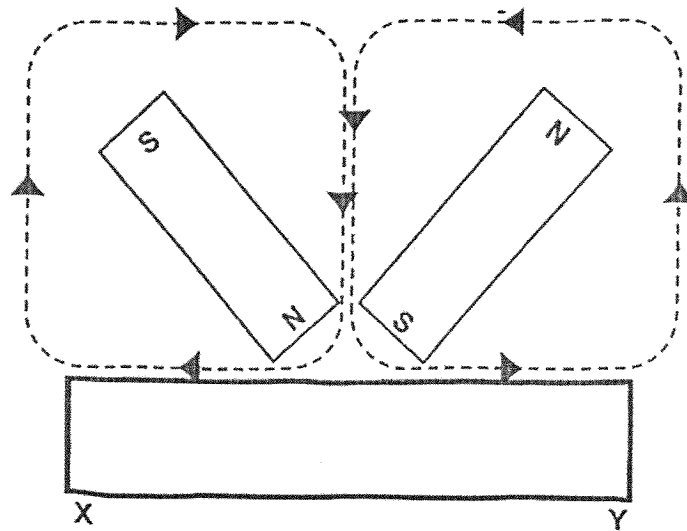
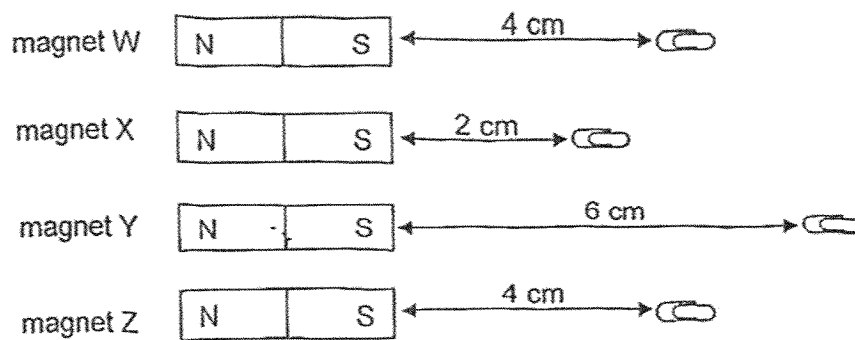

diagram 3

Which of the following are most likely the poles of steel bar XY?

	X	Y
(1)	North	South
(2)	North	North
(3)	South	North
(4)	South	South

- 15 The diagram shows the distance at which the different magnets, W, X, Y and Z, can attract a paper clip.



Which of the following best describes the observations?

- (1) Magnet Y is the weakest.
 - (2) Magnet Z is as strong as magnet W.
 - (3) Magnet W is weaker than magnet X.
 - (4) Magnet X is stronger than magnet Y.
- 16 The diagram shows the human digestive system.

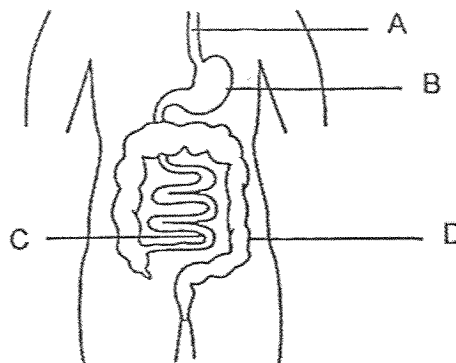

Digestion is completed at _____.

- (1) A
- (2) B
- (3) C
- (4) D

17 Which of the following is the function of the stem of a plant?

- (1) makes food
- (2) allows gases to enter or leave
- (3) absorbs water and mineral salts
- (4) holds the plant upright to get light

18 Abdul carried out an experiment with two similar plants as shown in set-ups 1 and 2.

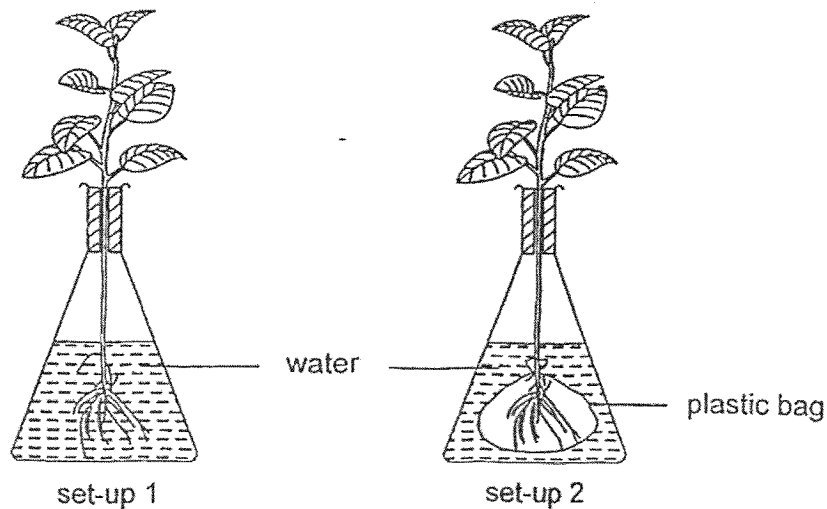

After one week, which of the following would he most likely observe?

- (1) There was less water in set-up 2 than in set-up 1.
- (2) There was no change in the plants in both set-ups.
- (3) The plant in set-up 2 grew taller than the plant in set-up 1.
- (4) The plant in set-up 1 grew taller than the plant in set-up 2.

- 19 Two boxes, X and Y, attached to a pump, have the same capacity of 500 cm^3 each. A ball of volume 50 cm^3 was placed inside box Y. Both boxes are then sealed with an air-tight cover.

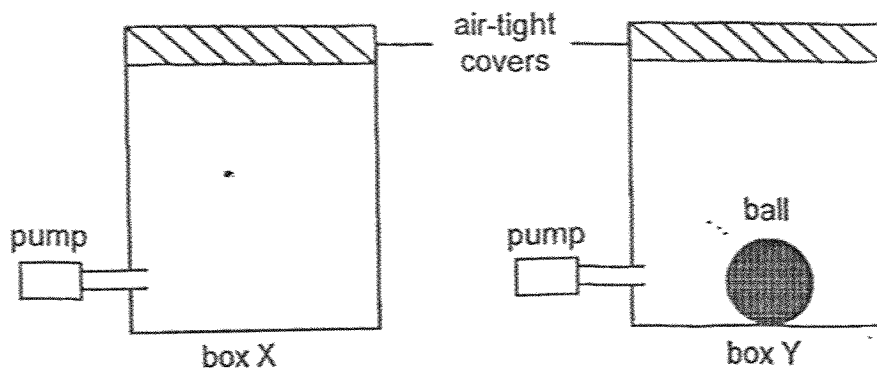

An additional 200 cm^3 of air was pumped into box X and 100 cm^3 of air was pumped into box Y.

Which of the following shows the final volume of air in each box?

Final volume of air in the box (cm^3)		
	Box X	Box Y
(1)	500	450
(2)	500	500
(3)	700	550
(4)	700	650

20 The diagram shows a container filled with substance Q being placed in two different positions, A and B. In both positions, substance Q occupied half of the container.

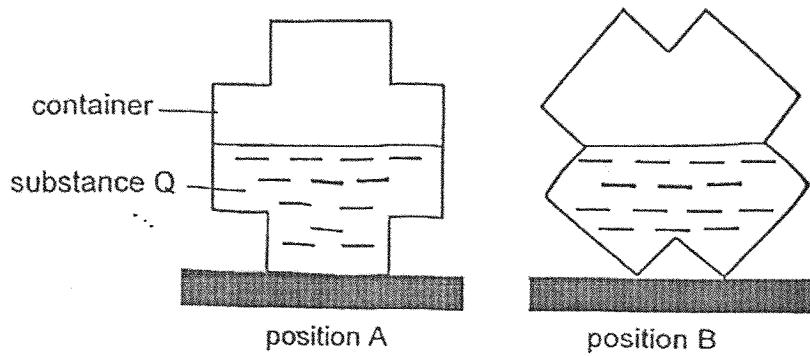

Based on the diagram, what can you conclude about substance Q?

- (1) Q has mass.
- (2) Q has a definite shape.
- (3) Q has a definite volume.
- (4) Q cannot be compressed.

- 21 Richard placed two solid balls, R and S, on a balance in set-up X. He then put each ball into two identical beakers containing the same amount of water in set-up Y.

He observed that the balance tilted to one side and the water level in both beakers rose to the same height.

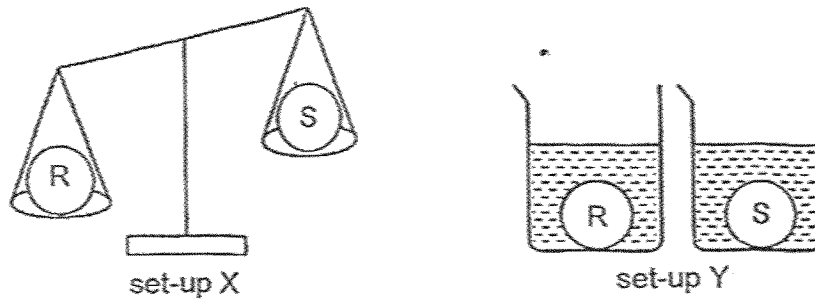

What conclusions can be made from the observations?

- A R has a greater mass than S.
- B R and S are made of the same material.
- C R and S have the same volume but different masses.

- (1) B only
- (2) A and B only
- (3) A and C only
- (4) A, B and C

- 22 Study the table.

Light sources	Non-light sources
Sun Moon lit candle	fire pencil mirror

Which items are not grouped correctly?

- (1) Moon and fire
- (2) mirror and Sun
- (3) Moon and mirror
- (4) pencil and lit candle

- 23 In an experiment, a ball was dropped between a light source and a light sensor as shown in the diagram.

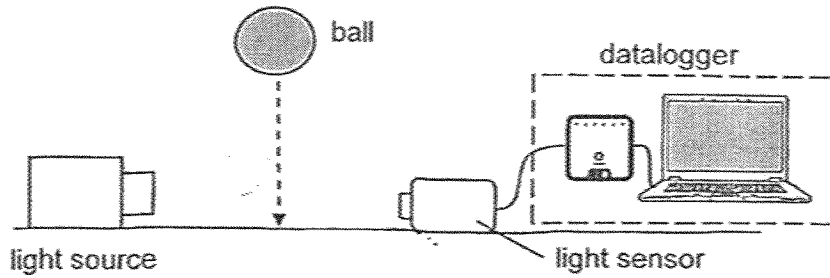

As the ball bounced, it bounced lower. The duration of light captured by the light sensor decreased. The amount of light detected by the light sensor was then recorded.

Which graph correctly shows the results of the experiment?

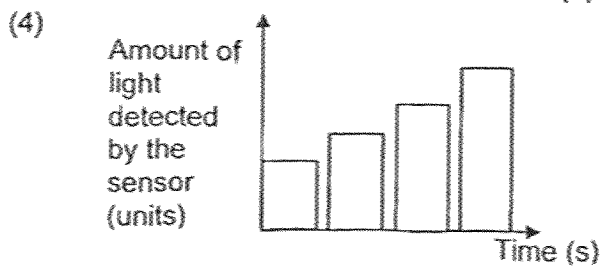
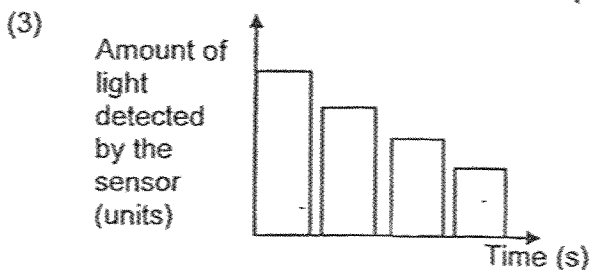
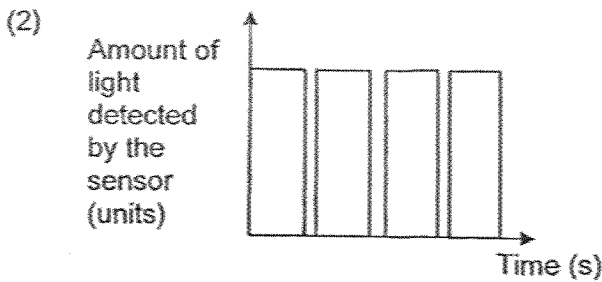
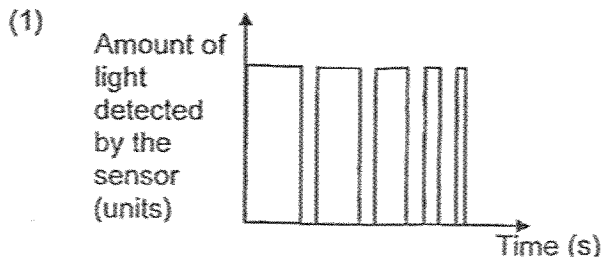

24 Glenn had three sheets of different materials cut into shapes.

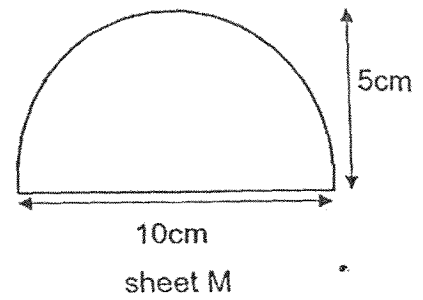
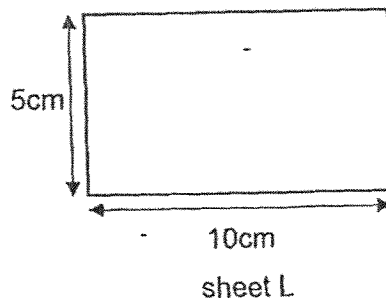
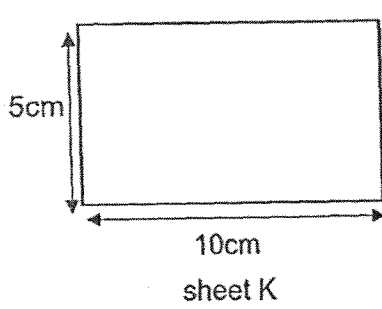

He conducted an experiment in a dark room using the set-up as shown.

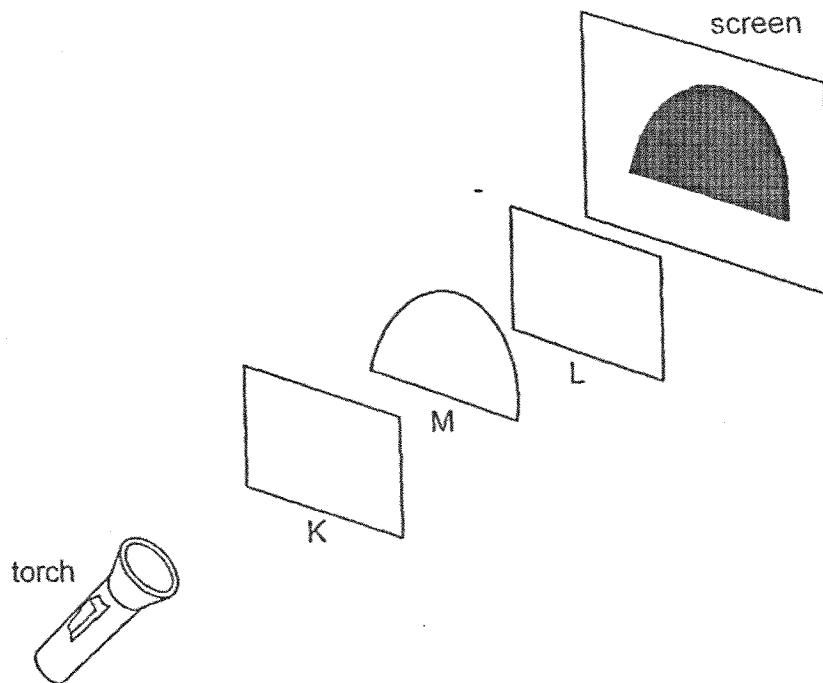

Glenn observed a shadow on the screen.

What conclusion about sheets K, L and M is correct?

	Allows light to pass through	Do not allow light to pass through	Not possible to tell
(1)	K	M	L
(2)	K	M and L	none
(3)	none	M	K and L
(4)	K and L	M	none

- 25 Ali wanted to find out how the distance between the light source and the object affects the size of the shadow.

He set up the experiment as shown and carried it out in a dark room, moving only the object while keeping the torch and screen at the same positions.

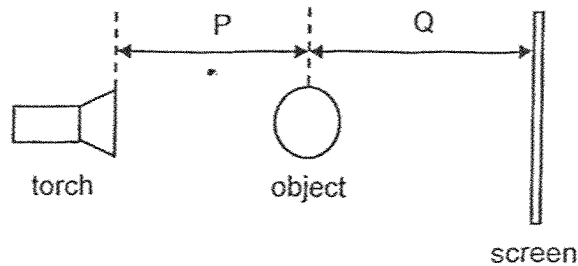

The results are as shown.

Distance P (cm)	Distance Q (cm)	Shadow
12	8	A
10	10	B
6	14	C

Based on the results, arrange the size of the shadow from the smallest to the largest

	Smallest	—————>	Largest
(1)	A		B C
(2)	B		C A
(3)	B		A C
(4)	C		B A

- 26 Which statement is correct?

- (1) Temperature is a form of energy.
- (2) Heat is the same as temperature.
- (3) Heat flows between two objects of different temperatures.
- (4) Temperature of an object can be accurately measured by touching it.

27 A metal spoon was placed in a bowl of hot soup.

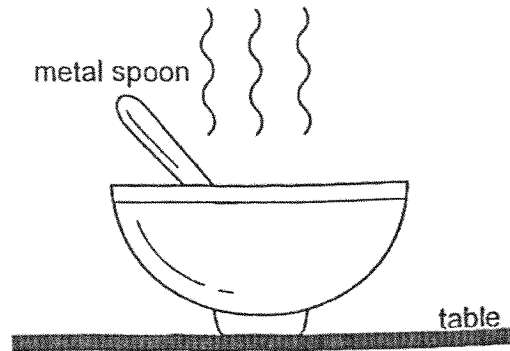

Which objects would gain heat?

- A bowl
- B soup
- C table
- D metal spoon

- (1) A and D only
- (2) B and C only
- (3) A, B and C only
- (4) A, C and D only

28 A, B, C and D are pieces of wax on the metal rod.

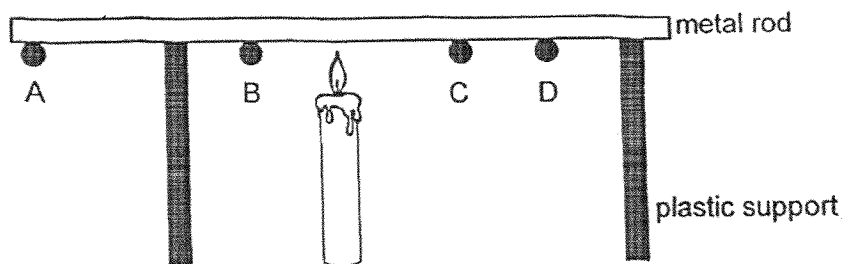

Which is the correct order in which the pieces of wax will drop?

	First to drop → Last to drop			
(1)	B	C	A	D
(2)	B	C	D	A
(3)	C	B	A	D
(4)	C	B	D	A

29 Mr Lim conducted an experiment by heating three rods of identical length made of different metals, P, Q and R, for thirty minutes. He recorded the length of each rod before and after heating.

Metal	Length before heating (mm)	Length after heating (mm)
P	300	312
Q	300	305
R	300	308

Mr Lim noticed that there were gaps on steel bridges as shown. He also observed that the gaps were smaller on a hot day.

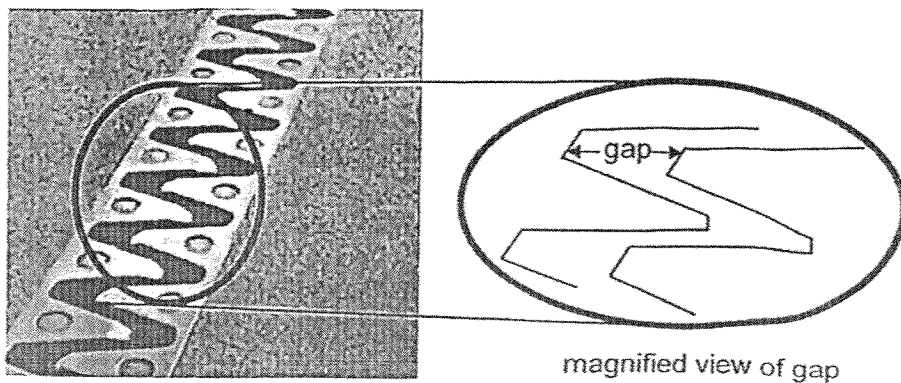

gaps on steel bridge

If metals P, Q and R were used to make the steel bridge, which metals would result in the smallest and largest gaps on the steel bridge on a hot day?

	Smallest gap	Largest gap
(1)	Q	P
(2)	Q	R
(3)	P	Q
(4)	P	R

- 30 Beakers A and B were filled with different amounts of water at 80 °C. A similar ice cube was placed in each beaker.

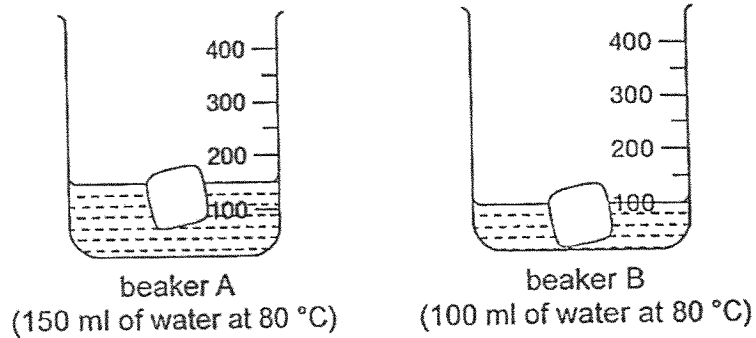

Which observation is correct?

- (1) The ice in both beakers melted because heat flowed from the ice to the water in the beakers.
- (2) The ice in both beakers would not change because there was no heat flow in both beakers.
- (3) The ice in beaker A melted faster than the ice in beaker B because there was more heat in beaker A.
- (4) The ice in beaker B melted faster than the ice in beaker A because there was more heat in beaker B.

End of Booklet A

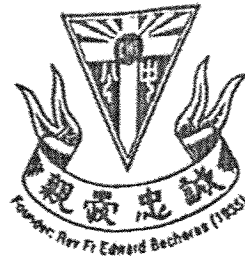

CATHOLIC HIGH SCHOOL
END-OF-YEAR EXAMINATION 2025
PRIMARY FOUR
SCIENCE
BOOKLET B

Name: _____ ()

Class: Primary 4 - _____

Date: 30 October 2025

Parent's Signature: _____

Booklet A	60
Booklet B	40
Total	100

11 questions

40 marks

Total Time for Booklets A and B: 1 hour 30 minutes

INSTRUCTIONS TO CANDIDATES

Do not turn over this page until you are told to do so.

Follow all instructions carefully.

Answer all questions.

Write your answers in this booklet.

This booklet consists of 15 printed pages, excluding the cover page.

For questions 31 to 41, write your answers in this booklet.

The number of marks available is shown in brackets [] at the end of each question or part question. (40 marks)

- 31 Mr Abdul conducted an experiment using two plants, A and B. The plants were placed in a garden and watered daily. He measured their heights on Day 0 and Day 14 as shown in the table.

Plant	Height of young plant at Day 0 (cm)	Height of young plant at Day 14 (cm)
A	10	13
B	10	18

- (a) Based on the results, which plant grew faster? [1]

- (b) In the table below, tick (✓) the variable(s) that Mr Abdul should keep the same to ensure a fair test. [1]

Variable	Tick (✓)
amount of water given to the plants daily	
height of the plant at the end of the experiment	
amount of sunlight the plants received	

(Go on to the next page)

SCORE	2
-------	---

Continue from Question 31

The diagram shows two plants, A and B.

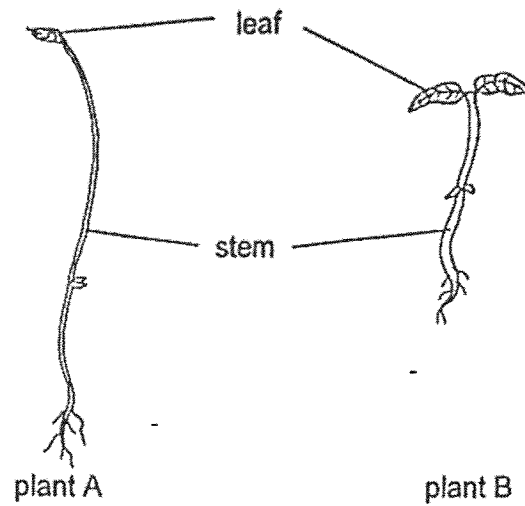

(c) State one difference between the stem of plant A and the stem of plant B.

The stem of plant A is _____ than the stem of plant B. [1]

(d) The leaves help both plants to make _____ in the light. [1]

(Go on to the next page)

SCORE	2
-------	---

32 (a) Kaile conducts an experiment to investigate how light travels.

Tick (✓) the box for the set-up that allows Kaile to see the candlelight through the hole at P.

[1]

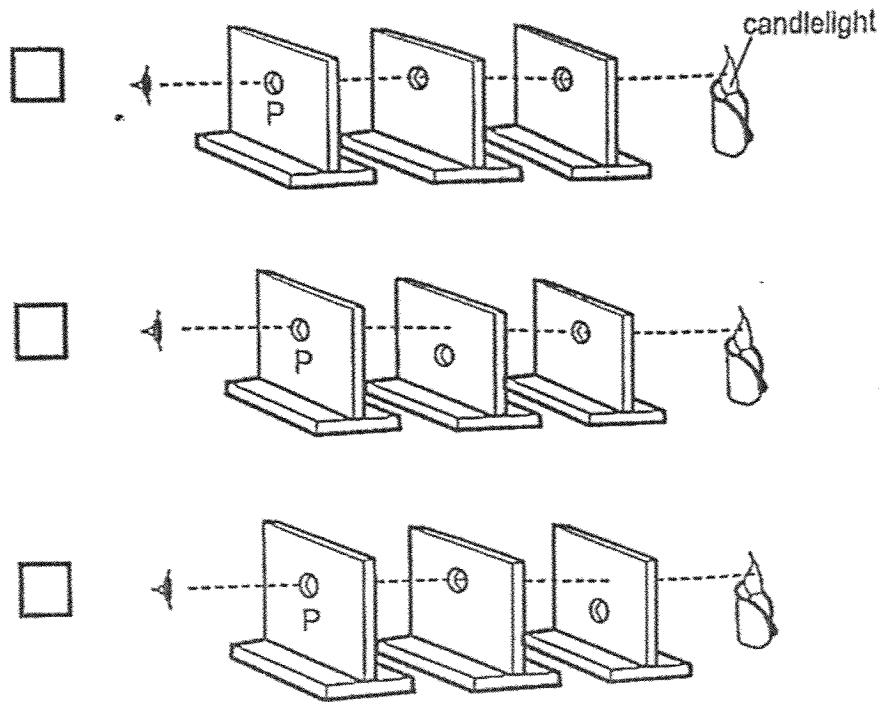

(b) State the property of light shown in the experiment above.

[1]

(Go on to the next page)

SCORE	2
-------	---

Continue from Question 32

Kaile hangs a wooden cylinder by a string directly below a lamp which is fixed to the ceiling.

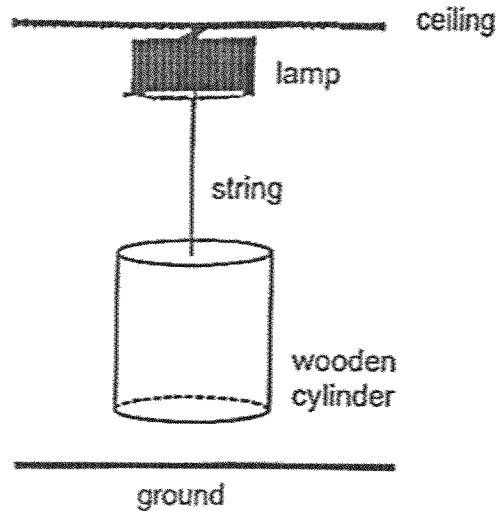

(c) State how the shadow of the wooden cylinder is formed on the ground. [1]

(d) The shadow of the cylinder is given. Using a pencil, draw the shadow of the cylinder as it would appear if the string is shorter, in the space provided. [1]

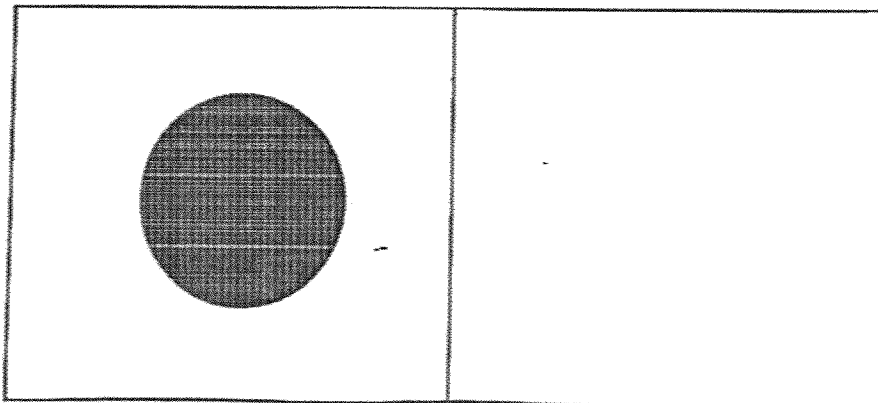

(Go on to the next page)

SCORE	2
-------	---

33 The diagram shows how Mary sees the ball.

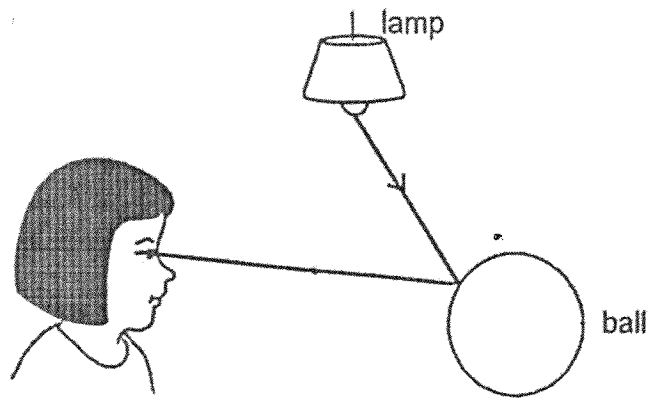

- (a) The _____ from the lamp is _____ by the ball and enters Mary's eye. [2]
- (b) Mary switches off the light and her room becomes dark. Explain why she can no longer see the ball. [1]

(Go on to the next page)

SCORE	3
-------	---

34 The diagram shows a beaker of water.

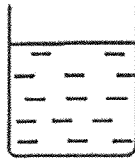

* For parts (a) and (b), fill in the blanks using the correct words in the box.

gas	decreases	solid
remains unchanged	increases	

(a) When water loses heat, its temperature _____ [1]

(b) The beaker of water is put in the freezer. After some time, the water will change its state to _____ [1]

The diagram shows a boiling kettle.

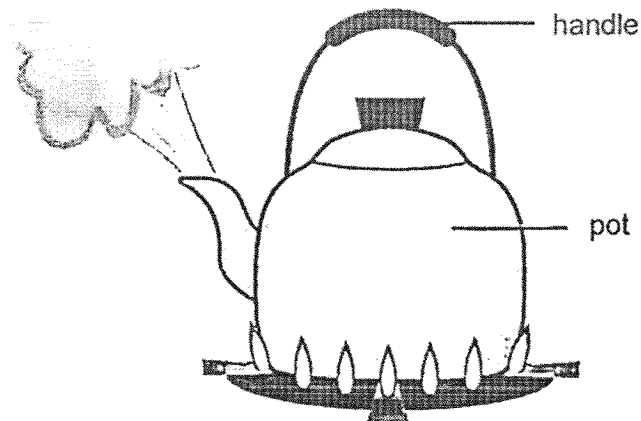

(c) The handle is made of plastic because it is a _____ conductor of heat. [1]

(d) The pot is made of metal because it is a _____ conductor of heat. [1]

(Go on to the next page)

SCORE	4
-------	---

35 Study the diagram.

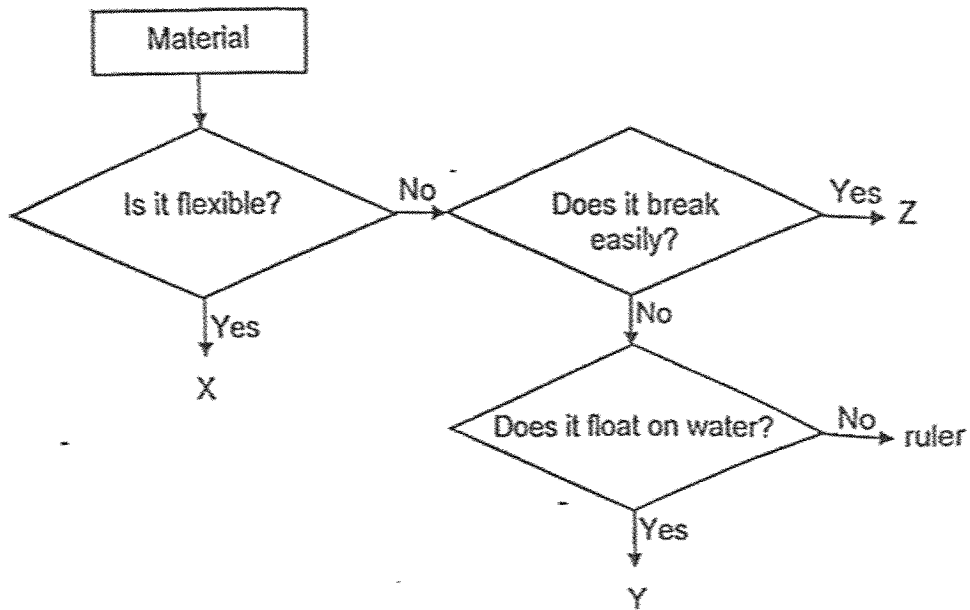

(a) Based on the diagram, state two properties of material Z. [1]

Prita used the set-up as shown to study a certain property of material.

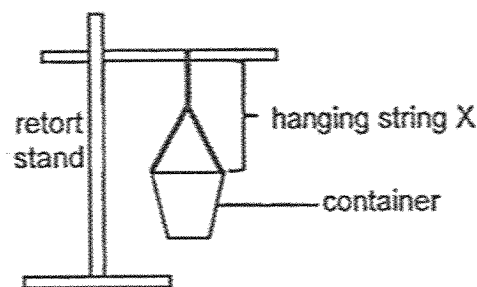

In her study, she used hanging strings of different materials, X, Y and Z. She increased the volume of water in the container until each hanging string broke. Her results are as shown.

Material	Volume of water needed for material to break (cm ³)
X	1000
Y	500
Z	200

(Go on to the next page)

SCORE	/
	1

Continue from Question 35

(b) Tick (✓) the boxes that represent the correct variables.

[1]

Variable to be	Material of hanging string	Volume of water added to container until the hanging string broke	Length of hanging string
changed			
kept the same			
measured			

(c) The picture shows a hanging potted plant.

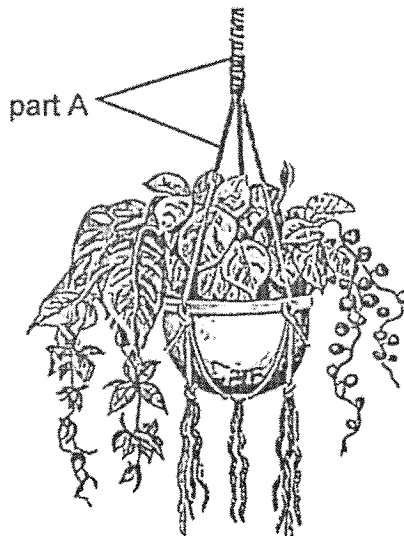

Based on the results, which material, X, Y or Z, is most suitable for making part A of the hanging potted plant? Explain your answer.

[2]

(Go on to the next page)

SCORE	3
-------	---

36 Study the table.

Animal	Body covering	Number of legs
P	hard outer covering	6
Q	hair	4
R	hard outer covering	8
S	moist skin	4

The animals were grouped as shown.

Group G
animal P animal R

- (a) Based on the information, state the characteristic that was used to classify the animals in Group G. [1]

Group G: _____

- (b) State one other difference between the characteristics of animals P and Q. [1]

(Go on to the next page)

SCORE	2
-------	---

37 Study the life cycles of a chicken and a cockroach.

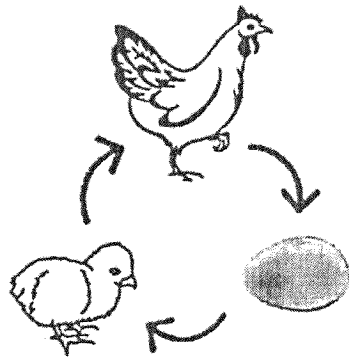

life cycle of a chicken

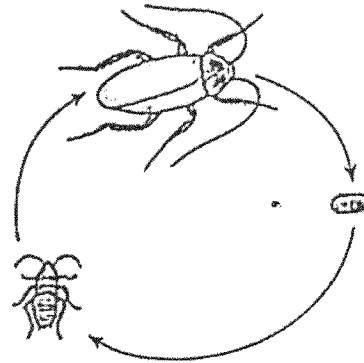

life cycle of a cockroach

(a) State a similarity between the life cycles of the chicken and the cockroach. [1]

(b) Name one animal which has a life cycle that is different from the chicken and the cockroach. [1]

(c) Explain how laying many eggs each time helps cockroaches in their survival. [1]

(Go on to the next page)

SCORE	3
-------	---

38 Mr Koh measured the mass of object X as shown in diagram 1.

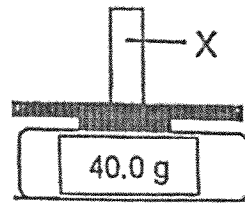

diagram 1

He placed object S above object X as shown in diagram 2 and repeated the experiment with object T as shown in diagram 3.

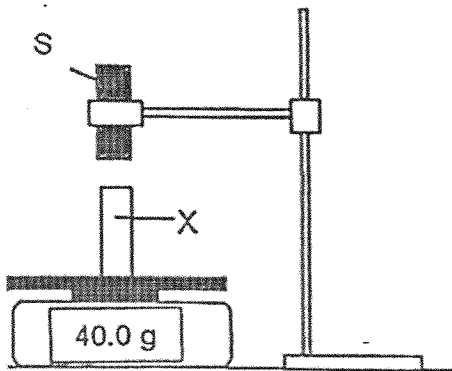

diagram 2

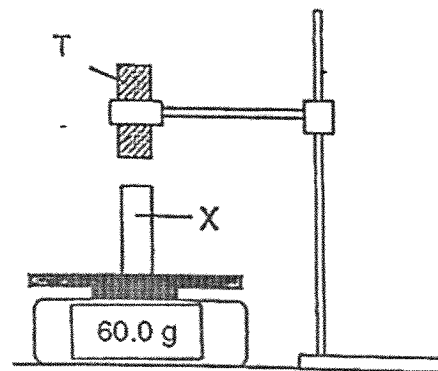

diagram 3

(a) Mr Koh made a few conclusions based on his observations. Tick (✓) the conclusions which are correct.

[1]

Conclusions	Tick (✓)
Both objects S and X are magnets.	
Both objects T and X are magnets.	
Object S is non-magnetic but object T is a magnet.	
Object S is magnetic but object T is non-magnetic.	

(Go on to the next page)

SCORE	1
-------	---

Continue from Question 38

The diagram shows three magnets.

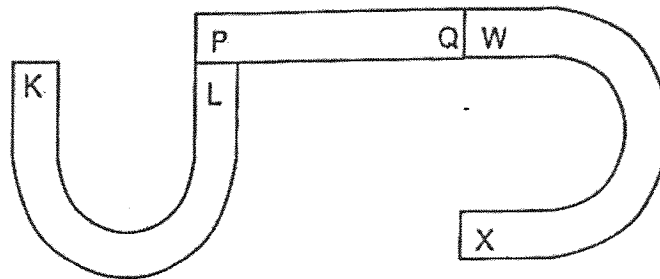

- (b) State what will happen when poles L and X are brought close together. Explain why. - [2]

(Go on to the next page)

SCORE	2
-------	---

39 The table shows the processes taking place in organs E and F.

Process	E	F
Digestion of food	x	✓
Absorption of water	✓	x
Chewing of food into smaller pieces	x	✓

Key
✓ yes
x no

(a) State what digestion is. [1]

(b) Identify organs E and F. [1]

E: _____

F: _____

(c) As babies do not have teeth, they are given porridge-like food that helps with digestion after swallowing. Explain how eating porridge-like food compared to larger pieces of food, helps with digestion. [2]

(Go on to the next page)

SCORE	4
-------	---

- 40 Shanti studied if air occupies space by covering a hole in the cover of a glass bottle and pouring milk into a funnel. Only a few drops of milk entered the bottle. When she uncovered the hole, the milk flowed freely into the bottle.

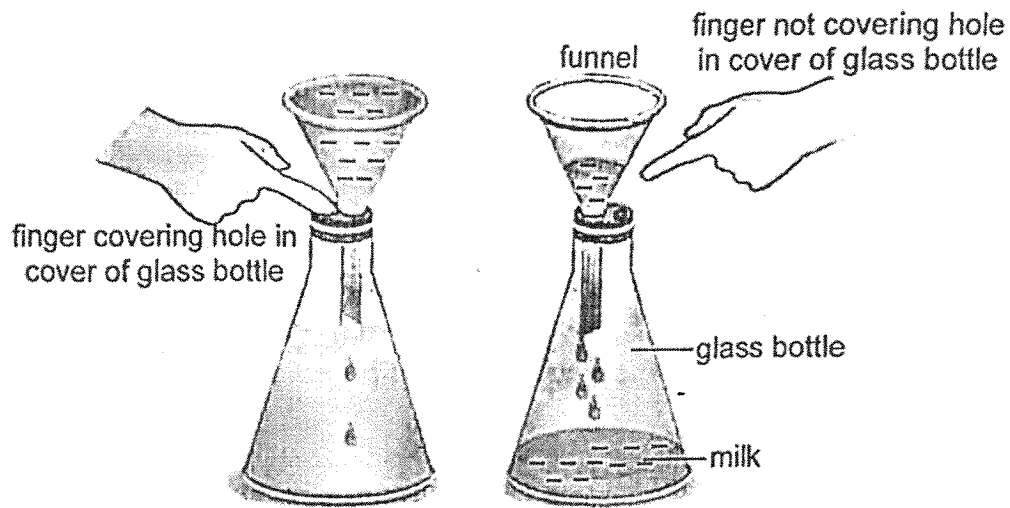

- (a) Tick (✓) the boxes showing the correct properties of the glass bottle and the milk. [2]

Item	Has definite shape	Has definite volume	Has mass
glass bottle			
milk			

- (b) Give a reason why only a few drops of milk entered the bottle when Shanti covered the hole with her finger. [1]

- (c) Explain why the milk entered the bottle when the hole was not covered by Shanti's finger. [2]

(Go on to the next page)

SCORE	5
-------	---

- 41 Marrie wrapped two identical empty drink cans in different materials as shown. She poured equal amounts of water at 60 °C into each can and left them on a table.

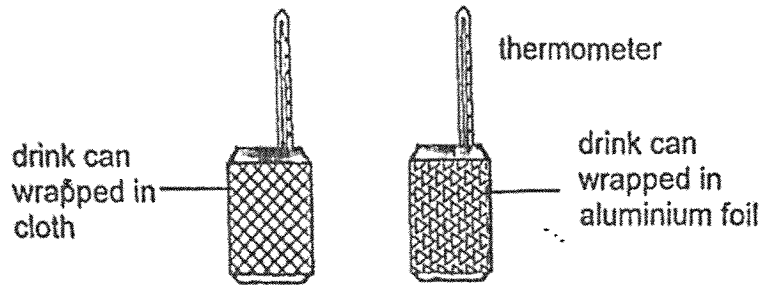

She recorded the time taken for the water to cool to the surrounding temperature of 32 °C. The results are as shown.

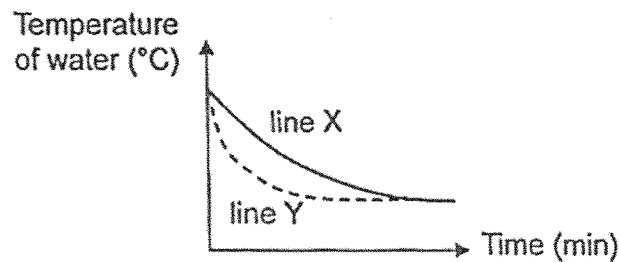

- (a) Based on the results, which line, X or Y, in the graph represents the drink can wrapped in cloth? Explain why. [2]

- (b) Marrie took a frozen chicken from the freezer to cook. Since it was frozen, she left it on a plate to defrost. State if Marrie should use a metal plate or a plastic plate to make the chicken defrost faster. Explain why. [2]

End of Booklet B

SCORE	4
-------	---

SCHOOL : CATHOLIC HIGH PRIMARY SCHOOL
LEVEL : PRIMARY 4
SUBJECT : SCIENCE
TERM : 2025 END OF YEAR EXAMINATION

Q1	Q2	Q3	Q4	Q5	Q6	Q7	Q8	Q9	Q10
1	1	2	4	2	2	3	2	4	4
Q11	Q12	Q13	Q14	Q15	Q16	Q17	Q18	Q19	Q20
3	3	2	3	2	3	4	4	1	3
Q21	Q22	Q23	Q24	Q25	Q26	Q27	Q28	Q29	Q30
3	1	1	4	1	3	4	2	3	3

www.sgexam.com

Name: _____ () Date: _____

Class: P4 _____

Corrections for P4 End-Of-Year Examination 2025

31a Plant B

b

Variable	Tick (✓)
amount of water given to the plants daily	✓
height of the plant at the end of the experiment	
amount of sunlight the plants received	✓

c The stem of plant A is taller than the stem of plant B.

d The leaves help both plants to make food in the light.

32a

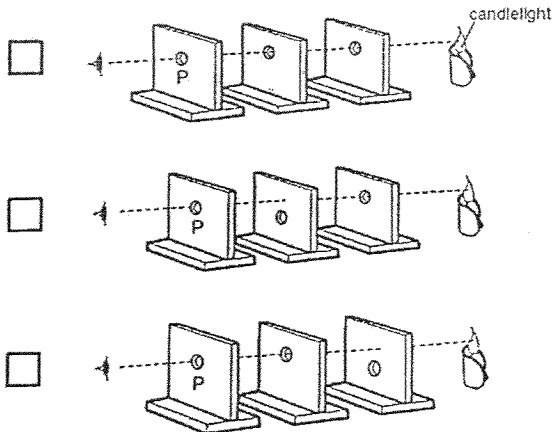

b Light travels in straight lines.

c The wooden cylinder blocked the light.

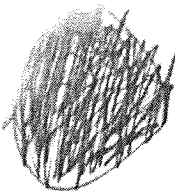
d				
33a	The <u>light</u> from the lamp is <u>reflected</u> by the ball and enters Mary's eye.			
b	There is <u>no</u> light source in her room [$\frac{1}{2}$] hence the ball <u>cannot reflect light</u> into her eyes [$\frac{1}{2}$].			
34a	When water loses heat, its temperature <u>decreases</u> .			
b	The beaker of water is put in the freezer. After some time, the water will change its state to <u>solid</u> .			
c	The handle is made of plastic because it is a <u>poor</u> conductor of heat.			
d	The pot is made of metal because it is a <u>good</u> conductor of heat.			
35a	Material Z is <u>not flexible</u> and <u>breaks easily</u> .			
b	Variables to be	Material of hanging string	Volume of water added to plastic vase until the hanging string broke	Length of hanging string
	changed	✓		
	kept the same			✓
	measured		✓	
c	(C) Material <u>X</u> (E) The volume of water added before the hanging string broke is the <u>most</u> . [1] (R) It is the <u>strongest</u> material. [1]			
36a	<u>outer covering</u>			
b	Animal Q <u>feeds</u> the young with milk but animal P does not. OR Animal P has 3 body parts but animal Q does not.			



Q37(a)	The young of both the chicken and the cockroach look like the adult . OR Both have three stages in their life cycles.																
Q37(b)	butterfly / mosquito / beetle																
Q37(c)	Some eggs may die / get eaten by other animals. So laying more eggs ensures some eggs may hatch and grow into adults.																
Q38(a)	Both objects T and X are magnets. ✓ Object S is non-magnetic but object T is a magnet. ✓																
Q38(b)	Poles L and X will repel as the like poles are facing each other.																
Q39(a)	Digestion is the process of breaking down food into simple substances that the body can absorb and use.																
Q39(b)	E: large intestine F: mouth																
Q39(c)	The porridge-like food has increased surface area in contact with digestive juices for digestion to be faster .																
Q40a	<table border="1"> <thead> <tr> <th>Item</th> <th>Has definite shape</th> <th>Has definite volume</th> <th>Has mass</th> </tr> </thead> <tbody> <tr> <td>Glass bottle</td> <td>✓</td> <td>✓</td> <td>✓</td> </tr> <tr> <td>Milk</td> <td>✗</td> <td>✓</td> <td>✓</td> </tr> <tr> <td></td> <td></td> <td></td> <td></td> </tr> </tbody> </table>	Item	Has definite shape	Has definite volume	Has mass	Glass bottle	✓	✓	✓	Milk	✗	✓	✓				
Item	Has definite shape	Has definite volume	Has mass														
Glass bottle	✓	✓	✓														
Milk	✗	✓	✓														
Q40b	Air occupied space in the glass bottle (so milk could not fully enter the bottle.)																

c	Air in the bottle could <u>escape</u> through the hole. [1] The milk could now enter the bottle to <u>occupy</u> the space previously occupied by the air in the bottle. [1]
41a	(C) Line X (E) The temperature of water <u>decreased slower</u> (for the same amount of time) OR The temperature of water <u>take longer</u> to reach the surrounding temperature of 32°C. [1] (R) Cloth is a <u>poorer</u> conductor of heat. Heat loss from the water to the surroundings was <u>slower</u> . [1]
b	(C) Metal plate. (E) Metal is a <u>better</u> conductor of heat. [1] (R) The chicken gained heat from the surroundings <u>faster</u> . [1]



