

Founded 1947

南侨小学

NAN CHIAU PRIMARY SCHOOL
END YEAR EXAMINATION
2025
SCIENCE
PRIMARY 4
BOOKLET A

| | | |
|-------------------------------|-----------------------------------------------------------------------------------------------------------------------------------------------------------------------------------------------------------------------------------------------------------------------------|-----|
| Name / Index no. | | () |
| Class | Primary 4 _____ | |
| Date | 22 October 2025 | |
| Duration for Booklets A and B | 1 h 45 min | |
| Marks | Booklet A | 60 |
| | Booklet B | 40 |
| | Total | 100 |
| Parent's Signature | | |
| Instructions to students | <ol style="list-style-type: none">1. Do not turn over this page until you are told to do so.2. Follow all instructions carefully.3. Answer all questions.4. Use a pencil to shade your answers on the Optical Answer Sheets (OAS). | |

This paper consists of 18 pages altogether.

For each question, four options are given. One of them is the correct answer. Make your choice (1, 2, 3 or 4) and shade your answer on the Optical Answer Sheet.

[60 marks]

1. The diagram below shows the life cycle of an animal.

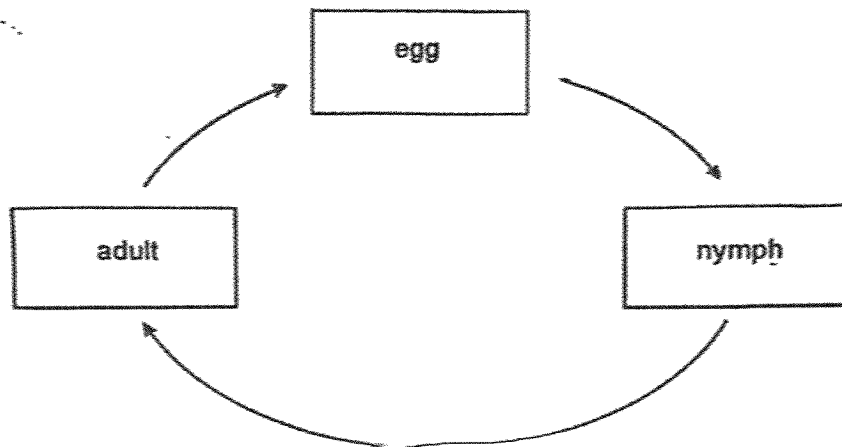

Which animal is likely to have the life cycle as shown above?

- (1) beetle
 - (2) chicken
 - (3) butterfly
 - (4) grasshopper
2. In which part of the digestive system is food absorbed into the blood?
- (1) mouth
 - (2) stomach
 - (3) small intestine
 - (4) large intestine

3. Which of the following objects is not made of waterproof material?

(1)

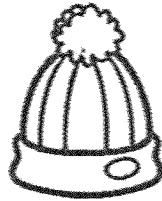

a cotton cap

(2)



a plastic umbrella

(3)

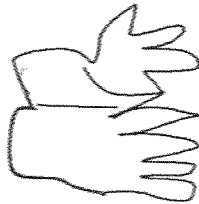

a pair of rubber gloves

(4)



a metal spoon

4. The diagram shows an axe.

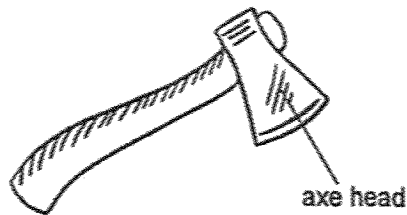

Metal is used to make the axe head of the axe because metal _____.

- (1) conducts heat well
- (2) does not break easily
- (3) can bend easily without breaking
- (4) does not allow light to pass through

5. In which one of the following will the two magnets pull towards each other?

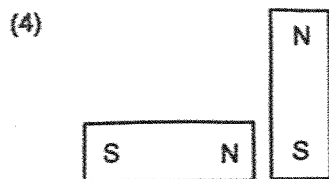
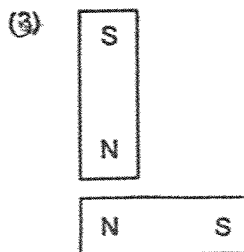
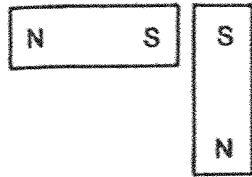

6. Matter is anything that has mass and occupies space.

Which one of the following is not matter?

- (1) air
- (2) milk
- (3) sand
- (4) shadow

7. Study the diagram below.

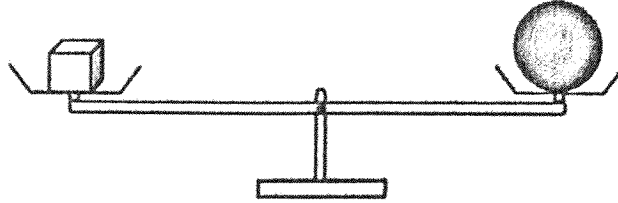

Both objects have the same _____.

- (1) size
- (2) mass
- (3) shape
- (4) volume

8. Study the diagram below.

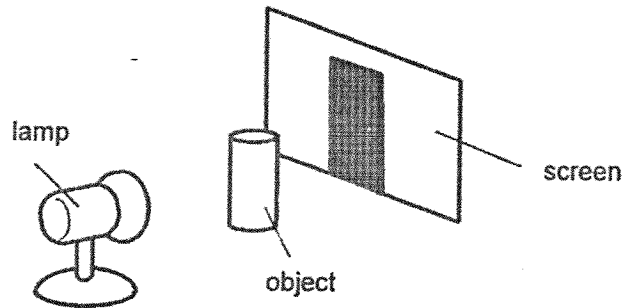

The shadow of the object is formed on the screen because _____.

- (1) the object blocks light
- (2) the object reflects light
- (3) the object gives off light
- (4) the screen absorbs light

9. Warm water at 75°C is mixed with cold water at 15°C

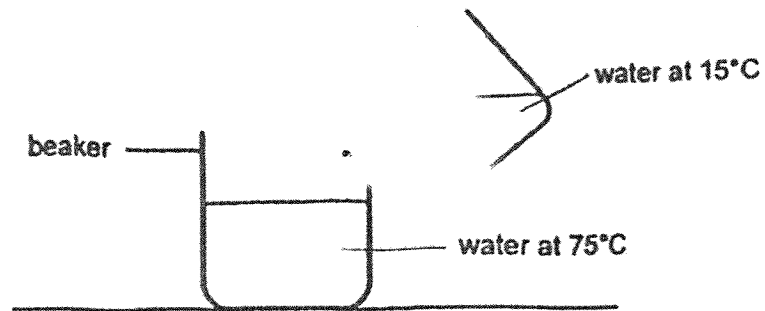

What is a possible final temperature of water in the beaker?

- (1) 90°C
 - (2) 75°C
 - (3) 50°C
 - (4) 15°C
10. Hashim fried an egg in a frying pan shown below.

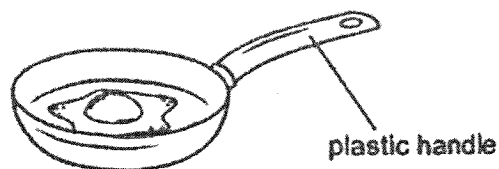

He could hold the frying pan using the plastic handle. This is because plastic is a _____.

- (1) light material
- (2) flexible material
- (3) good conductor of heat
- (4) poor conductor of heat

11. Study the chart below carefully.

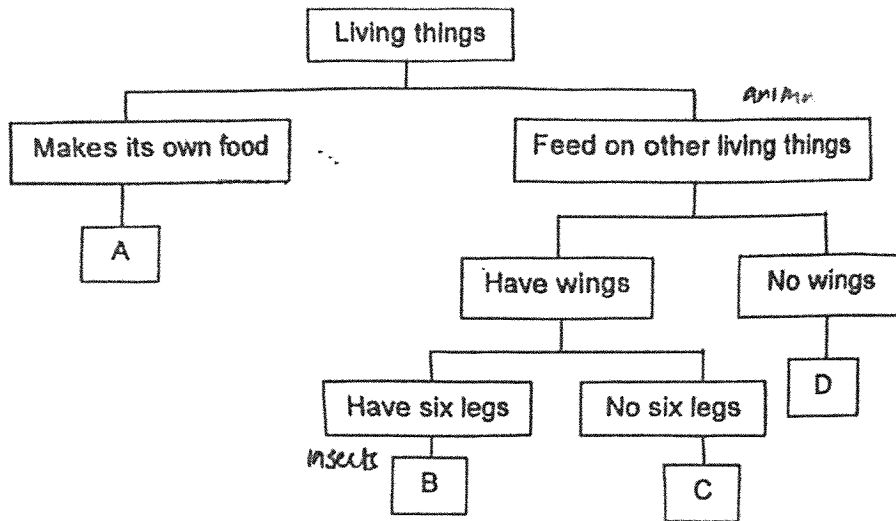

Which letters A, B, C or D best represent a bird's nest fern and a chicken?

| | Bird's nest fern | Chicken |
|-----|------------------|---------|
| (1) | C | A |
| (2) | A | D |
| (3) | A | C |
| (4) | D | B |

12. Some animals are classified into four groups as shown below.

| E | F | G | H |
|---------|-------|-------|----------|
| bat | goose | shark | lizard |
| dolphin | eagle | guppy | tortoise |

They are grouped according to _____.

- (1) what they eat
- (2) where they live
- (3) how they move about
- (4) what their bodies are covered with

13. The table below shows organs that can be found in different human body systems.

Which of the following incorrectly matches the organ to the system?

| | Organ | System |
|-----|-----------------|-------------|
| (1) | blood vessels | circulatory |
| (2) | mouth | digestive |
| (3) | small intestine | muscular |
| (4) | windpipe | respiratory |

14. Mandy observed a plant that was removed from a pot. Some of the roots were wrapping the soil tightly while some were deep in the soil as shown below.

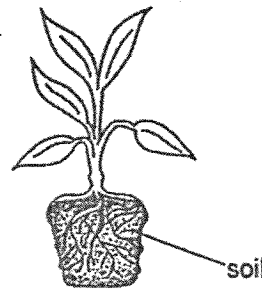

Which of the statements are correct about the roots?

- A: It helps to support the branches.
- B: It helps to make food for the plant.
- C: It helps to hold the plant to the soil.
- D: It helps to absorb water for the plant.

- (1) A and B only
- (2) B and C only
- (3) C and D only
- (4) A, B, C and D

15. Lina observed a plant as shown below.

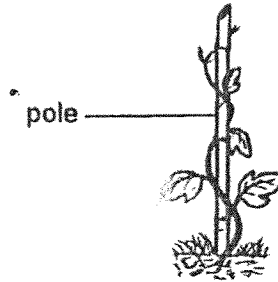

Based on her observation, Lina concluded that the plant _____.

- (1) cannot make food
- (2) has a strong stem
- (3) has roots to hold the plant upright
- (4) depends on the pole to reach to a greater height

16. Joseph wrapped the roots of a plant and placed it into a beaker of water as shown below. He then left the plant under the Sun for a week.

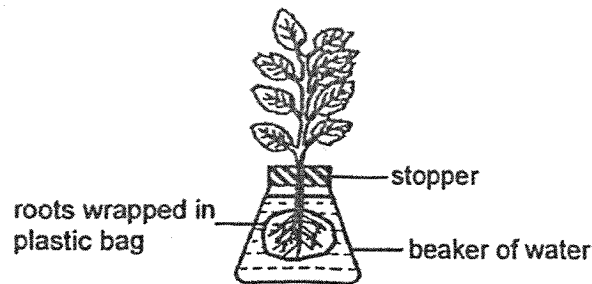

Based on the information above, what would happen to the water level in the beaker and what was the reason for the change?

| | Water level | Explanation |
|-----|----------------|-------------------------------------------------------------|
| (1) | decrease | The plant took in water to make food. |
| (2) | did not change | The plant could not take in water as plastic is flexible. |
| (3) | did not change | The plant could not take in water as plastic is waterproof. |
| (4) | increase | The plant made food and released water into the beaker. |

17. Using two similar plants, Joan placed two plants near the window. After one week, she recorded the amount of water left in the beakers.

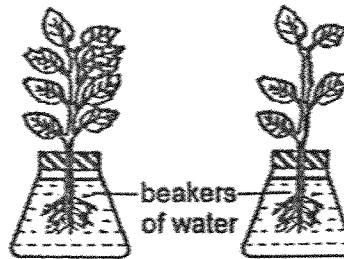

Based on the setup above, Joan was trying to find out if _____.

- (1) plants need leaves to make food
 - (2) plants need roots to absorb water
 - (3) the type of plant affects the amount of water absorbed
 - (4) the number of leaves affect the amount of water absorbed
18. Susan has four setups L, M, N, J using two different types of plants P and Q as shown below.

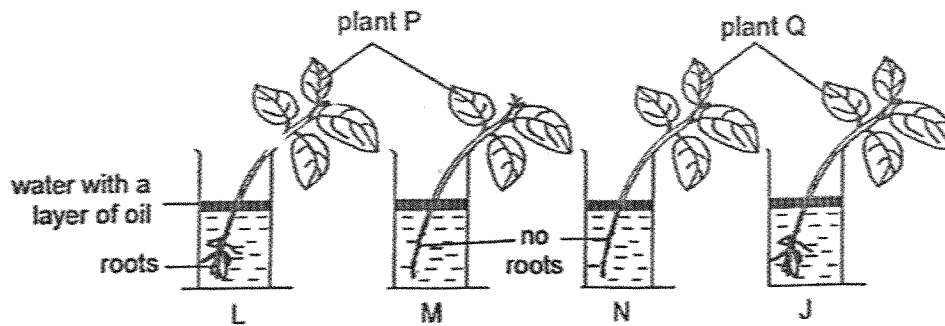

Which pair of setups should Susan choose if she wants to find out whether roots are needed for the survival of the plants?

- (1) L and M
- (2) L and N
- (3) M and J
- (4) N and J

19. The diagram below shows a machine that separates a mixture of materials into two bins X and Y.

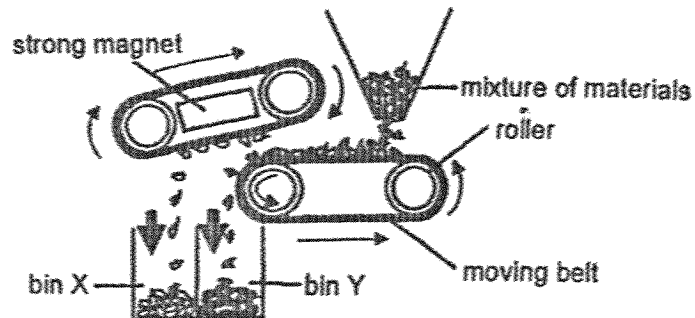

Which of the following shows the materials that are collected in bins X and Y?

| | Bin X | Bin Y |
|-----|-------|---------|
| (1) | wood | plastic |
| (2) | steel | glass |
| (3) | iron | steel |
| (4) | glass | iron |

20. The number of iron nails that electromagnets X, Y and Z could attract is recorded in the table below.

| Electromagnet | Number of iron nails attracted |
|---------------|--------------------------------|
| X | 7 |
| Y | 16 |
| Z | 4 |

Based on the above results, which of the following setups could represent electromagnets X, Y and Z correctly?

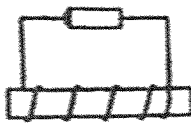
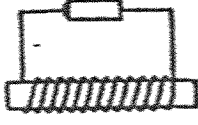
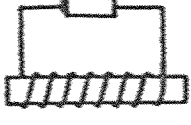
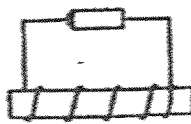
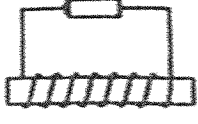
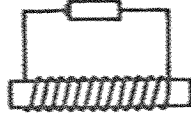
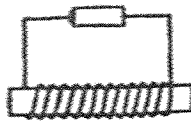
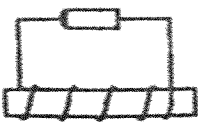
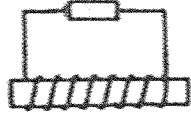
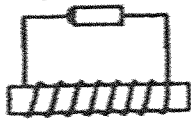
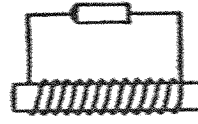
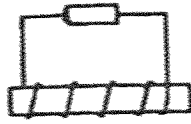
| | X | Y | Z |
|-----|-------------------------------------------------------------------------------------|-------------------------------------------------------------------------------------|---------------------------------------------------------------------------------------|
| (1) |  |  |  |
| (2) |  |  |  |
| (3) |  |  |  |
| (4) |  |  |  |

21. A glass beaker containing boiling water was left on the table.

Which of the following action(s) would not help cool the boiling water quickly?

- A: put a metal spoon in the water
- B: cover the top of the beaker with a wooden lid
- C: wrap the beaker with a cloth that was wet with tap water

- (1) A only
- (2) B only
- (3) A and C only
- (4) B and C only

22. Jaden placed a glass of ice cubes into a basin of hot water as shown below.

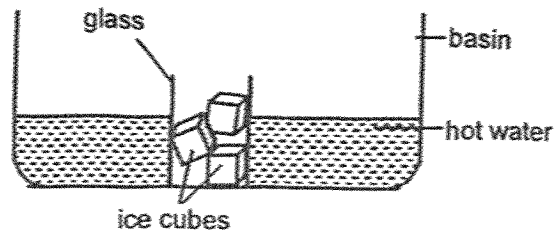

Which of the following statements on heat gain and heat loss is correct?

- (1) Ice cubes lost heat to the hot water.
- (2) Ice cubes gained heat from the glass.
- (3) The hot water gained heat from the basin.
- (4) The glass gained coldness from the ice cubes.

23. Four similar drops of wax were placed at positions A, B, C and D of a rectangular metal frame.

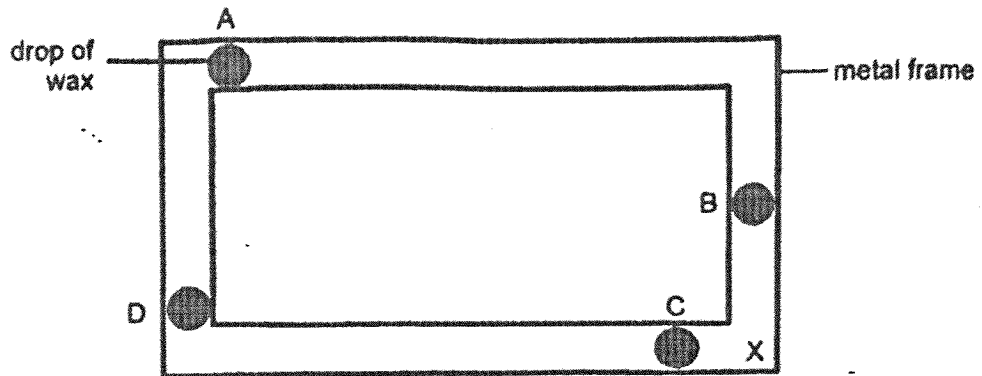

Jie Ning heated the metal frame at position X. She recorded the time taken for the wax to melt completely in the table below.

| Position of wax | Time taken (min) |
|-----------------|------------------|
| A | ? |
| B | 7 |
| C | 2 |
| D | 12 |

Based on the results above, which of the following shows a possible timing for the wax at position A to melt completely?

- (1) 1
- (2) 8
- (3) 10
- (4) 14

24. Tyden placed four similar uncooked eggs into beakers W, X, Y and Z which contained water at different temperatures and different volumes. The eggs were left in the beaker for 10 minutes.

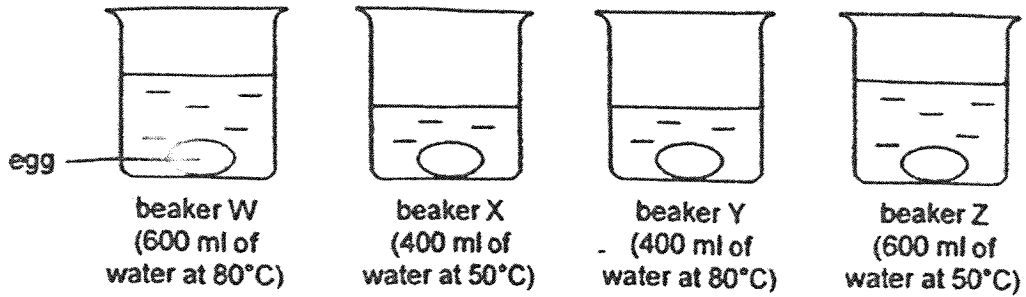

After 10 minutes, Tyden cracked each of the eggs to find out how cooked it was. Which beaker had the most and least cooked egg?

| | Most cooked | Least cooked |
|-----|-------------|--------------|
| (1) | W | Z |
| (2) | Y | Z |
| (3) | Y | X |
| (4) | W | X |

25. An experiment was set up using a sealed container which holds 60 cm³ of water and 40 cm³ of air as shown below. 10 cm³ of water was removed from the container through tap A and 20 cm³ of air was then pumped in using pump Q.

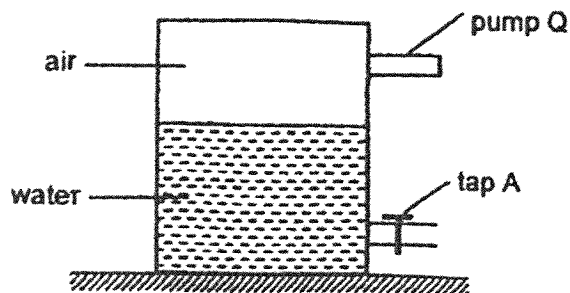

What would be the final volume of air in the container?

- (1) 20 cm³
- (2) 40 cm³
- (3) 50 cm³
- (4) 70 cm³

26. Aden suspended a metal bar into a basin of water as shown below.

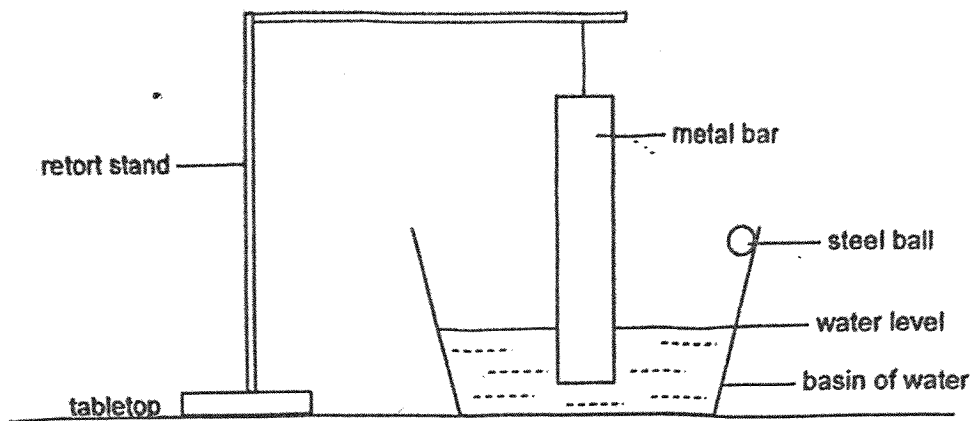

What will happen to the water level and the volume of water in the basin when Aden rolls a steel ball gently into the water?

| | Water level | Volume of water |
|-----|-------------|------------------|
| (1) | increases | remains the same |
| (2) | decreases | increases |
| (3) | increases | increases |
| (4) | decreases | remains the same |

27 Figure 1 shows a balloon filled with air, floating on water in a container.

When the balloon was pushed downwards, some water in the container overflowed as shown in figure 2.

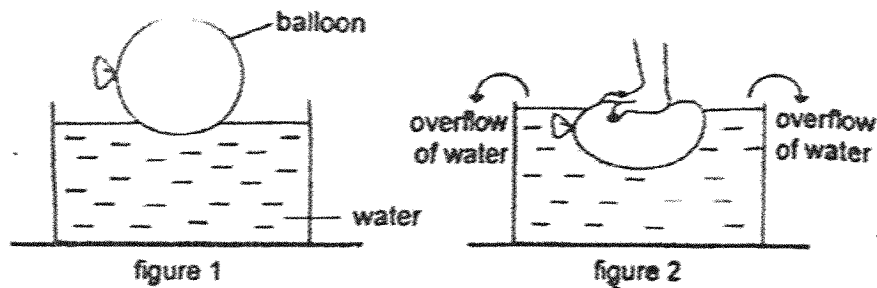

Which one of the following can be concluded from the overflow of water in figure 2?

- (1) Air has mass.
- (2) Air occupies space.
- (3) Air has no definite shape.
- (4) Air has no definite volume.

28. Arif set up an experiment below to find out how the thickness of an object would affect the amount of light passing through it.

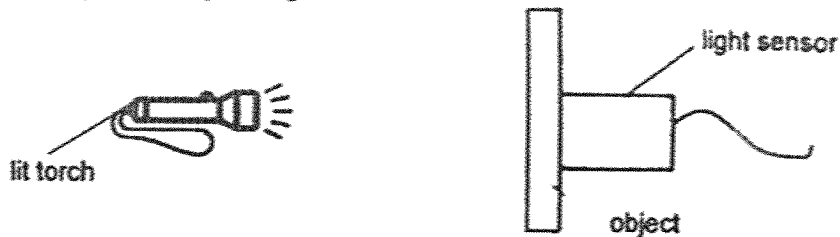

Which of the following variables should Arif keep the same to ensure a fair test?

- A: the torch
- B: the material of the object
- C: the thickness of the object
- D: the distance between the light sensor and the lit torch

- (1) A and B only
- (2) C and D only
- (3) A, B and D only
- (4) B, C and D only

29. The setup below shows light shining on three cardboard cut-outs A, B and C. They are placed at different distances from the lit torch.

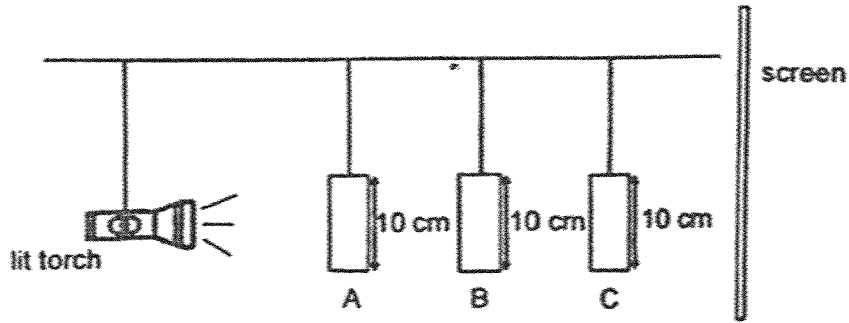

The diagram below shows the shadow of the objects on the screen.

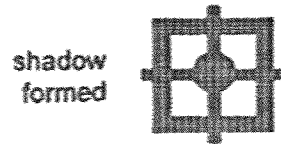

What one of the following correctly represents the three objects A, B and C respectively?

| | A | B | C |
|-----|---|---|---|
| (1) | | | |
| (2) | | | |
| (3) | | | |
| (4) | | | |

30. Jackie stood under a lit lamp as shown below.

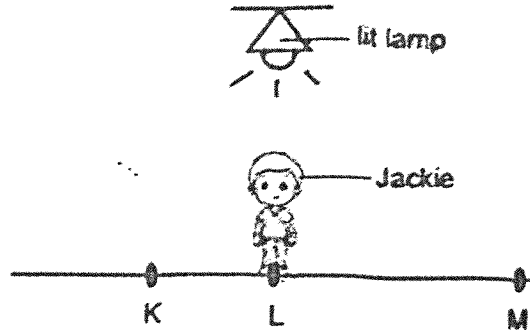

He walked from position L to K, and then to position M.

Which graph shows how the length of his shadow changed overtime as he walked?

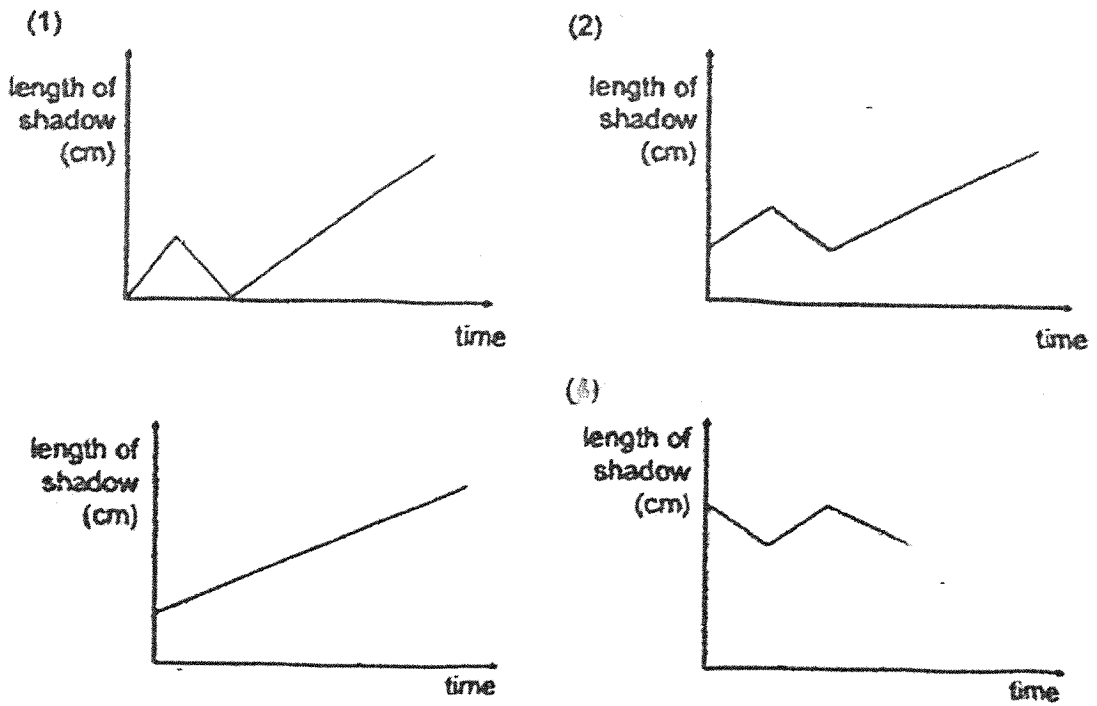

End of Booklet A

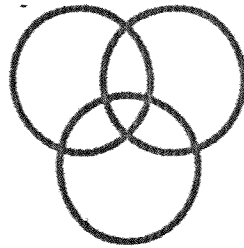

Founded 1947

南侨小学
NAN CHIAU PRIMARY SCHOOL
END YEAR EXAMINATION
2025
SCIENCE
PRIMARY 4
BOOKLET B

| | | |
|-------------------------------|----------------------------------------------------------------------------------------------------------------------------------------------------------------------------------------------------------------------------------------------------------------------------------------------------------------------------------------------------------------------------------------------------------------------------|-----|
| Name / Index no. | | () |
| Class | Primary 4 _____ | |
| Date | 22 October 2025 | |
| Duration for Booklets A and B | 1 h 45 min | |
| Marks | Booklet B | 40 |
| Parent's Signature | | |
| Instructions to students | <ol style="list-style-type: none">1. Do not turn over this page until you are told to do so.2. Follow all instructions carefully.3. Answer all questions.4. Use a dark blue or black ballpoint pen to write your answers in the space provided for each question.5. Do not use correction fluid/tape or highlighters. <p>This paper consists of 16 pages altogether.</p> | |

For questions 31 to 41, write your answers in this booklet.

The number of marks available is shown in [] at the end of each question or part question.

[40 marks]

31. Draw lines to match the following animals to the correct groups.

[3]

(a)

Animal

Group

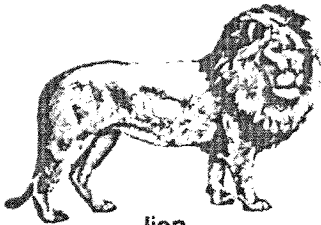

lion

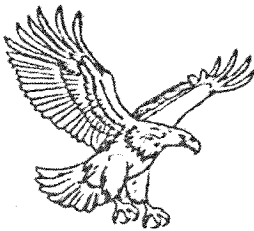

eagle

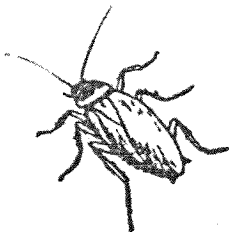

cockroach

● birds

● mammals

● amphibians

● insects

(b) Identify the difference between the lion and the eagle based on the way they reproduce.

[1]

1

| | |
|-------|---|
| SCORE | 4 |
|-------|---|

32. The diagram shows different stages (A, B and C) in the growth of a young plant.

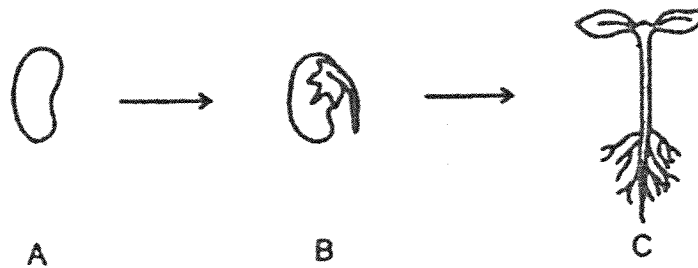

(a) Fill in the blanks using the correct words in the box.

| | | | | | |
|---|---|---|------|--------|-------|
| A | B | C | stem | leaves | roots |
|---|---|---|------|--------|-------|

The young plant in stage _____ and _____ cannot make food because it does not have _____.

[3]

(b) Explain why the plant at stage C cannot reproduce.

[1]

33. Study the diagram carefully. Magnet G is brought near another magnet F.

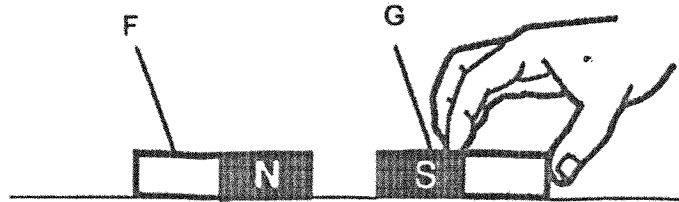

(a) As the different poles of both magnets are facing each other, F and G will

_____.

[1]

Magnet G is then brought near a small steel ball.

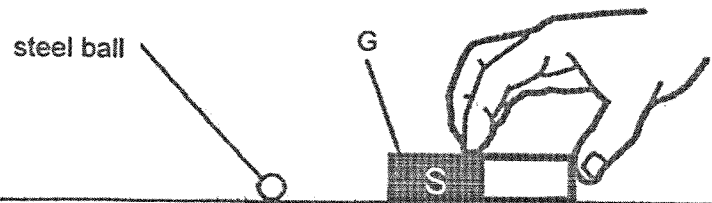

(b) Tick (✓) the box that shows the direction the steel ball will move.

[1]

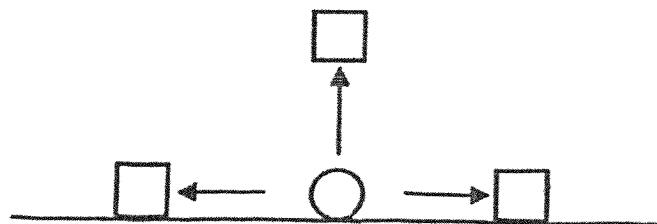

| | |
|-------|--------------------------|
| SCORE | <input type="checkbox"/> |
| | 2 |

34. Water is poured into a measuring cylinder containing some metal balls.

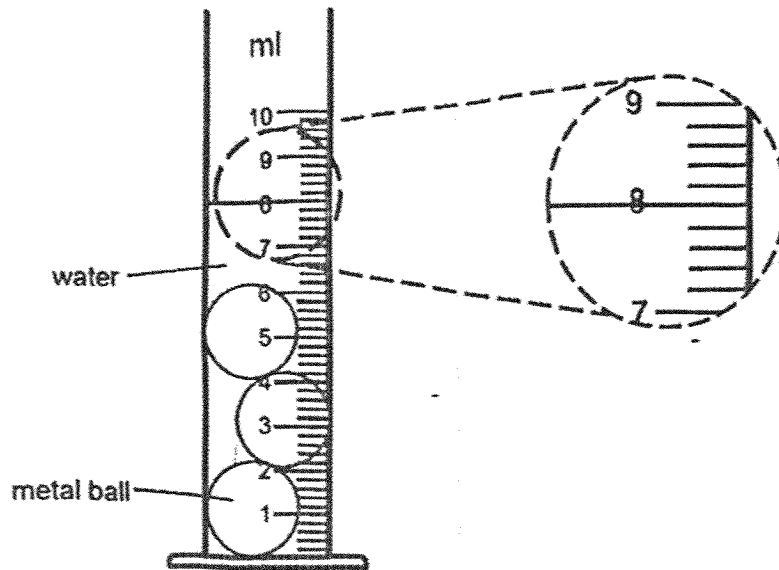

(a) State the reading of the water level.

[1]

_____ ml

Circle the correct answer.

(b) The volume of water in the measuring cylinder is

(less than equal to / more than) than my answer

in (a).

[1]

| | |
|-------|---|
| SCORE | / |
| | 2 |

35. Christine placed a seed on some wet cotton wool on a dish. She observed the growth of the seed over time and drew her observations below.

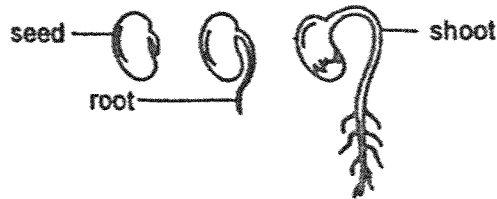

Christine also measured the length of the root and shoot and recorded the data in the table below.

| Day | Length of root (mm) | Length of shoot (mm) |
|-----|---------------------|----------------------|
| 0 | 0 | 0 |
| 2 | 3 | 0 |
| 4 | 6 | 3 |
| 6 | 9 | 6 |
| 8 | 12 | 12 |

- (a) Christine observed that the roots grew out first. Explain why.

[1]

Please continue question 35 on the next page.

Christine then investigated how surrounding temperature affected the growth of seeds. She placed same number of seeds on moist cotton wool on different dishes. After a week, she counted the number of seeds that grew and plotted the graph as shown below.

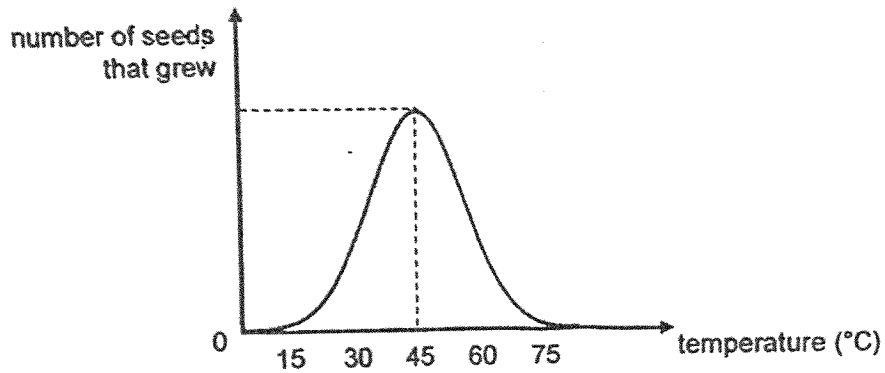

- (b) Based on the graph above, identify two relationships between the temperature and the number of seeds that grew. [2]

- (i) _____

- (ii) _____

- (c) Besides using the same number of seeds in each dish, tick (✓) the variables that Christine should keep the same to ensure a fair test. [1]

- type of seeds
- amount of water
- location where the dishes are placed

36. The graph below shows the amount of digested food in the different parts of the human digestive system.

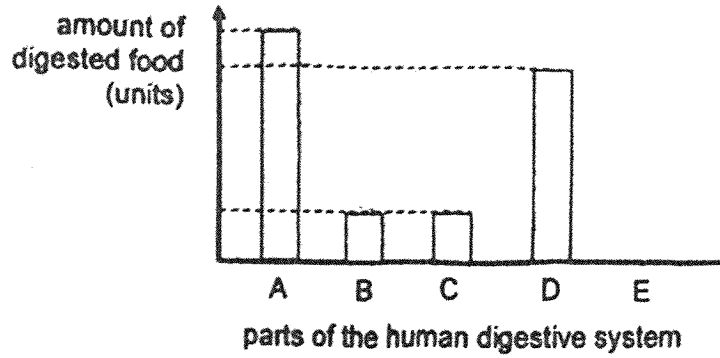

- (a) If part B represents the mouth, which part A, C, D or E represents the gullet? Explain your answer.

[1]

- (b) Which part A, C, D or E best represents the large intestine? Explain your answer.

[1]

Please continue question 36 on the next page.

The diagram below shows the cross-section of the small intestine.

The inner layer contains many folds that are in contact with the food undergoing digestion.

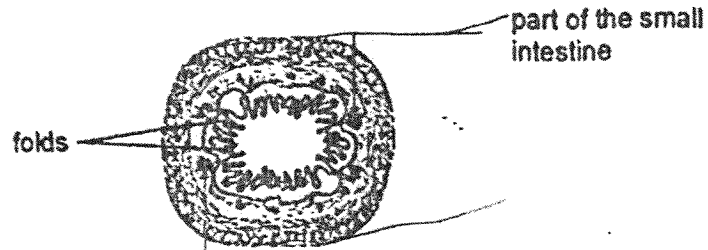

- (c) Explain how the many folds in the small intestine help in the absorption of digested food. [2]

| | |
|-------|--|
| SCORE | |
|-------|--|

37. Keith drew a flowchart as shown below.

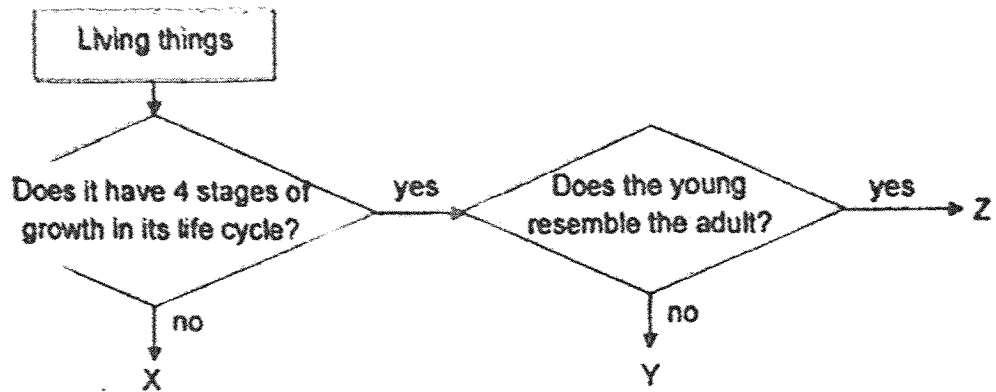

(a) Which letter X, Y or Z best represents a butterfly? [1]

Keith caught some young of the butterflies and placed them into a container with air, food and water. Over time, he noticed that some dead skin could be seen in the container and the young stopped feeding.

(b) Suggest two reasons why the young stopped feeding. [2]

(i) _____

(ii) _____

(c) At which stage of the life cycle would he observe the dead skin? [1]

38. Lily has a ring that fits perfectly on her finger.

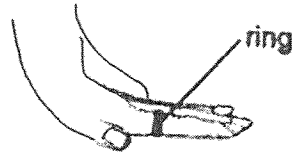

She left her ring near an open window on a hot day. When she wore the ring, it slipped off her finger.

(a) Explain why the ring slipped off her finger.

(b) After 15 minutes, Lily realised the ring fits perfectly again. Explain why.

[1]

The pavement was laid on warm soil. When a cold wind blew, cracks appeared on it.

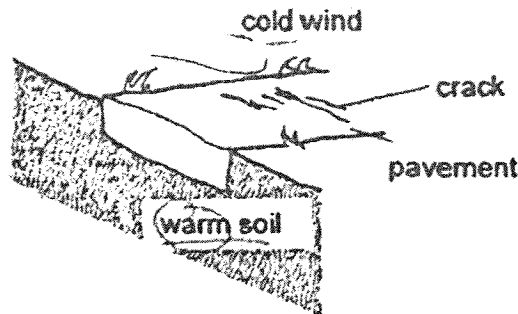

(c) Using the concept of heat gain and heat loss, explain what happened to the top and bottom parts of the pavement that caused the cracks.

[2]

| | |
|-------|---|
| SCORE | 4 |
|-------|---|

39. The diagram shows a light sensor which is used to count the number of people entering a mall.

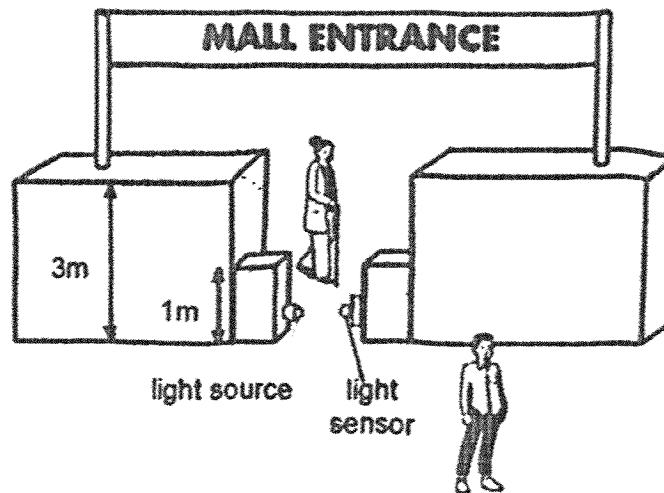

The space between the light source and light sensor allows one person to enter the mall each time. The readings of the light sensor are recorded in the graph below.

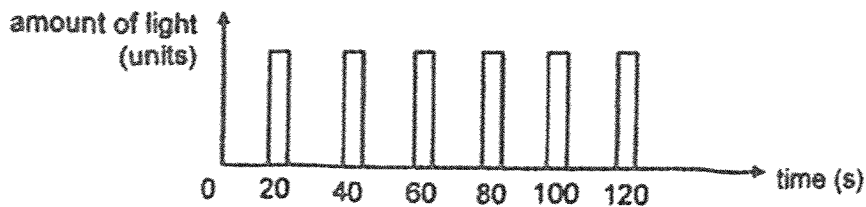

- (a) How many people entered the mall in the first 80 seconds?

[1]

Please continue question 39 on the next page.

The light source and light sensor were moved to part X and part Y as shown above.

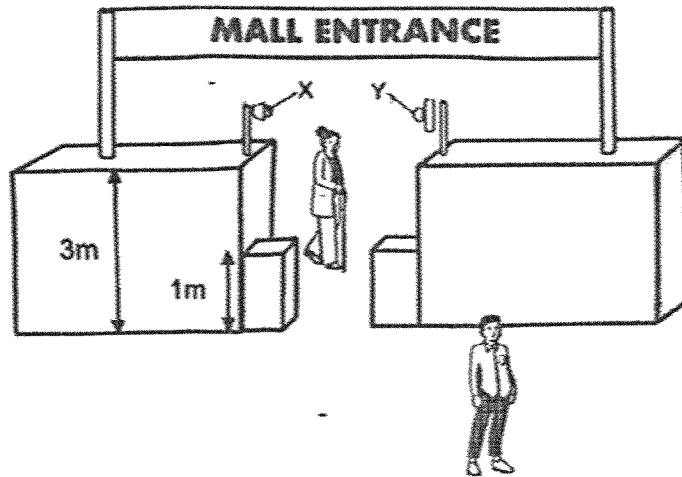

- (b) After they were moved, the light sensor was not able to count the number of people entering the mall. Explain why. [2]

- (c) Which property of light allows the light sensor to count the number of people entering the mall? [1]

| | |
|-------|---|
| SCORE | 4 |
|-------|---|

40. Suzanne used a thermometer to measure the temperature of water.

(a) State what temperature means.

[1]

Suzanne wanted to find out if the thickness of a material affects the temperature of water. She filled three identical beakers with equal amounts of hot water and placed them in three containers M, N and O.

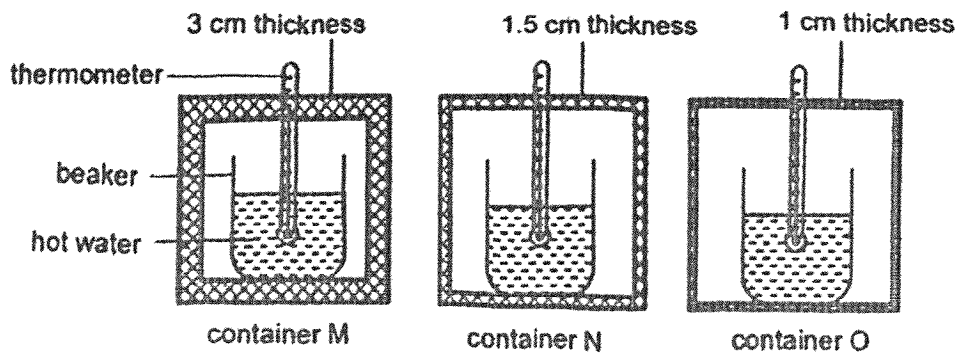

Suzanne recorded her results in the table.

| Container | Temperature of water | |
|-----------|--------------------------|-----------------------|
| | Start of experiment (°C) | After 30 minutes (°C) |
| M | 90 | 82 |
| N | 90 | 54 |
| O | 90 | 42 |

(b) Based on the results above, how did the thickness of the material affect the temperature of the water after 30 minutes?

[1]

Please continue question 40 on the next page.

- (c) Suzanne wants to keep a can of cold drink as cold as possible for the longest time. Which container M, N or O should she use? Explain your answer. [2]

| | |
|-------|---------------------------------------------------------------------------------------|
| SCORE |  |
|-------|---------------------------------------------------------------------------------------|

41. Imran wanted to find out whether the number of turns of wire around the iron nail would affect the magnetic strength of an electromagnet. He used similar iron nails to prepare setups A, B, C and D, as shown below.

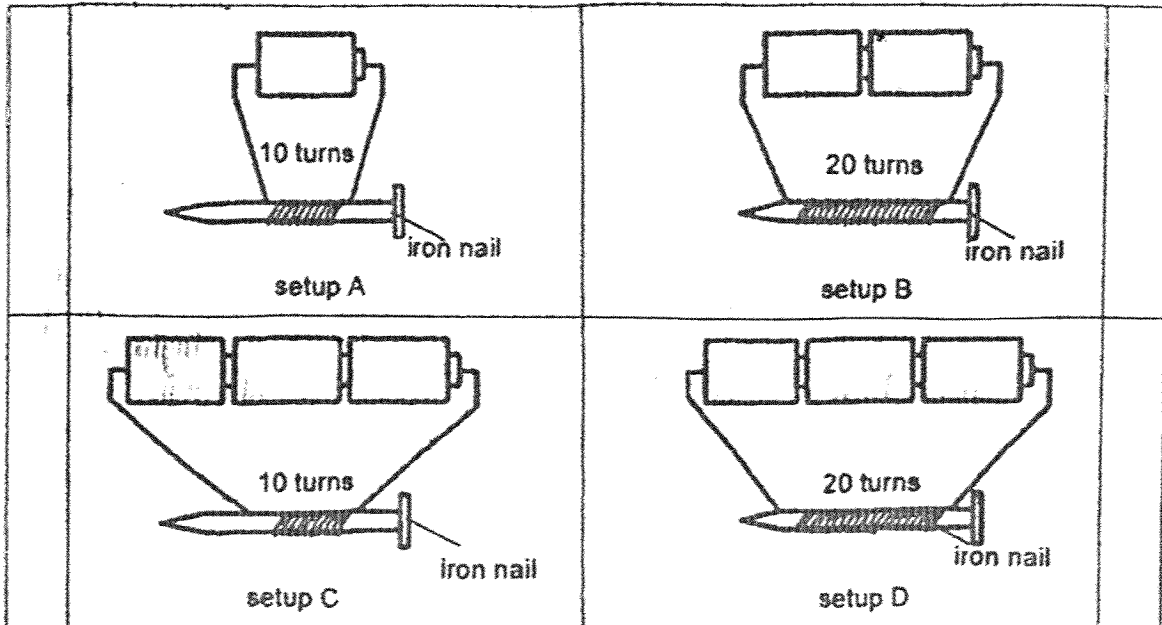

- (a) Which two setups A, B, C or D, should Imran use for a fair test? [1]

- (b) Imran conducted another experiment using only setups B and D. When both setups were placed near a bed of steel paper clips, the electromagnet in one setup attracted more paper clips.

In which setup B or D would the electromagnet attract more paper clips? [2]
Explain your answer.

Please continue question 41 on the next page.

- (c) Imran replaced the iron nail in setup A with a copper nail
Would the steel paper clips be attracted? Explain your answer.

[1]

End of Paper

| | |
|-------|---|
| SCORE | 4 |
|-------|---|

SCHOOL : NAN CHIAU PRIMARY SCHOOL
LEVEL : PRIMARY 4
SUBJECT : SCIENCE
TERM : 2025 END OF YEAR EXAMINATION

| | | | | | | | | | |
|-----|-----|-----|-----|-----|-----|-----|-----|-----|-----|
| Q1 | Q2 | Q3 | Q4 | Q5 | Q6 | Q7 | Q8 | Q9 | Q10 |
| 4 | 3 | 1 | 2 | 4 | 4 | 2 | 1 | 3 | 4 |
| Q11 | Q12 | Q13 | Q14 | Q15 | Q16 | Q17 | Q18 | Q19 | Q20 |
| 3 | 4 | 3 | 3 | 4 | 3 | 4 | 4 | 2 | 4 |
| Q21 | Q22 | Q23 | Q24 | Q25 | Q26 | Q27 | Q28 | Q29 | Q30 |
| 2 | 2 | 4 | 4 | 3 | 1 | 2 | 3 | 4 | 2 |

www.sgexam.com

Nan Chiau Primary School
 Primary 4 Science
 End Year Examination 2025
 Booklet B (Answer Key)

Name: _____ ()

Class: _____

| Qn. | Answer |
|-------|----------------------------------------------------------------------------------------------------------------------------------------------------------------------------------------------------------------------------------------------------|
| 31(a) | <p>[C]</p> |
| (b) | [C] The lion gives birth to its young alive while the eagle lay eggs. |
| 32(a) | The young plant in stage [C] <u>A</u> and [C] <u>B</u> cannot make food because it does not have [C] <u>leaves</u> . |
| (b) | The plant at stage C is [E] not an adult plant and it does not have flowers and fruits which are needed for reproduction. |
| 33(a) | As the different poles of both magnets are facing each other, F and G will [C] <u>attract</u> . |
| (b) | <p>[C]</p> |
| 34(a) | [C] 8 ml |
| (b) | The volume of water in the measuring cylinder is [C] <u>less than</u> my answer in (a). |
| 35(a) | The roots grew out first to [R] absorb water for the seed to grow. |
| (b) | <p>[E1] As temperature increases from 0°C to 45°C, the number of seeds that grew also increases. [E2] As temperature increases beyond 45°C, the number of seeds that grew decreases.</p> |
| (c) | <p>[C]</p> <ul style="list-style-type: none"> <input checked="" type="checkbox"/> type of seeds <input checked="" type="checkbox"/> amount of water <input type="checkbox"/> location where the dishes are placed |

| | |
|-----------|--------------------------------------------------------------------------------------------------------------------------------------------------------------------|
| 36(a) | C. The amount of digested food in B and C are the same. This shows that no digestion takes place in C. |
| 36(b) | E. There is no digested food in E. Digestion ends at the small intestine. |
| 36(c) | The folds increase the surface area of the small intestine in contact with the digestive juices. This allows food to be digested faster. |
| 37(a) | Y |
| 37(b)(i) | Some of them have developed into the pupa stage. |
| 37(b)(ii) | Some of them have died. |
| 37(c) | Larva stage. |
| 38(a) | The ring gained heat from the Sun and expanded. |
| 38(b) | The ring lost heat to her finger and contracted. |
| 38(c) | The top part of the pavement would lose heat to the cold wind and contract. The lower part of the pavement would gain heat from the warm soil and expand. |
| 39(a) | 4 |
| 39(b) | Part X and Part Y are higher. The light from the light source will not be blocked by the person entering the mall. |
| 39(c) | Light travels in a straight line. |
| 40(a) | Temperature is a measurement of how hot or cold an object is. |
| 40(b) | As the thickness of the material increases, the temperature of water after 30 minutes also increases. |
| 40(c) | Container M. The temperature of water at the end of the experiment is the highest. This shows that the material would gain heat from the surroundings the slowest. |
| 41(a) | C and D |
| 41(b) | Setup D. There are more batteries. The electromagnet has a stronger magnetism. |
| 41(c) | The paper clips would not be attracted as copper is non-magnetic and cannot be magnetised. |

www.sgexam.com