



**ST. HILDA'S PRIMARY SCHOOL**  
**END-OF-YEAR EXAMINATION, 2025**

**PRIMARY 4**

**SCIENCE**

**Booklet A**

Name : \_\_\_\_\_ (    )

Class: Primary 4 / \_\_\_\_\_

Date: 22 October 2025

**Total Time for Booklets A and B: 1 hour 45 minutes**

Additional Materials: Optical Answer Sheet (OAS)

**INSTRUCTIONS TO CANDIDATES**

1. Write your name, index number and class above.
2. Do not turn over this page until you are told to do so.
3. Follow all instructions carefully.
4. Answer all questions.
5. Use a 2B pencil to shade your answers on the Optical Answer Sheet (OAS).

This booklet consists of 22 printed pages.

For each question from 1 to 30, four options are given. One of them is the correct answer. Make your choice (1, 2, 3 or 4) and shade your answer on the Optical Answer Sheet.

(60 marks)

1 Which of the statements is **not** true about all living things?

- (1) They can grow.
- (2) They can move.
- (3) They can reproduce by laying eggs.
- (4) They need air, food and water to stay alive.

2 The following table shows some characteristics of organisms W, X, Y and Z.

Organism	Able to make its own food	Lives on land	Reproduces by spores
W	✓	✓	✓
X	x	✓	✓
Y	x	✓	x
Z	x	x	x

Key:  
✓: Yes  
x: No

The diagram below shows a fern growing on a tree.

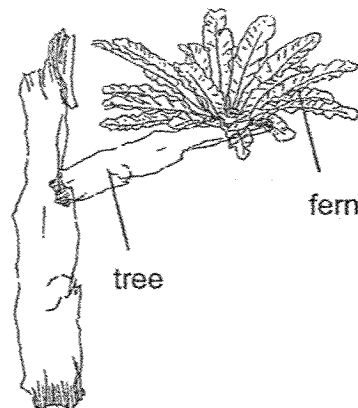

Which organism, W, X, Y or Z best represents the fern?

- (1) W
- (2) X
- (3) Y
- (4) Z

3 Study the chart below.

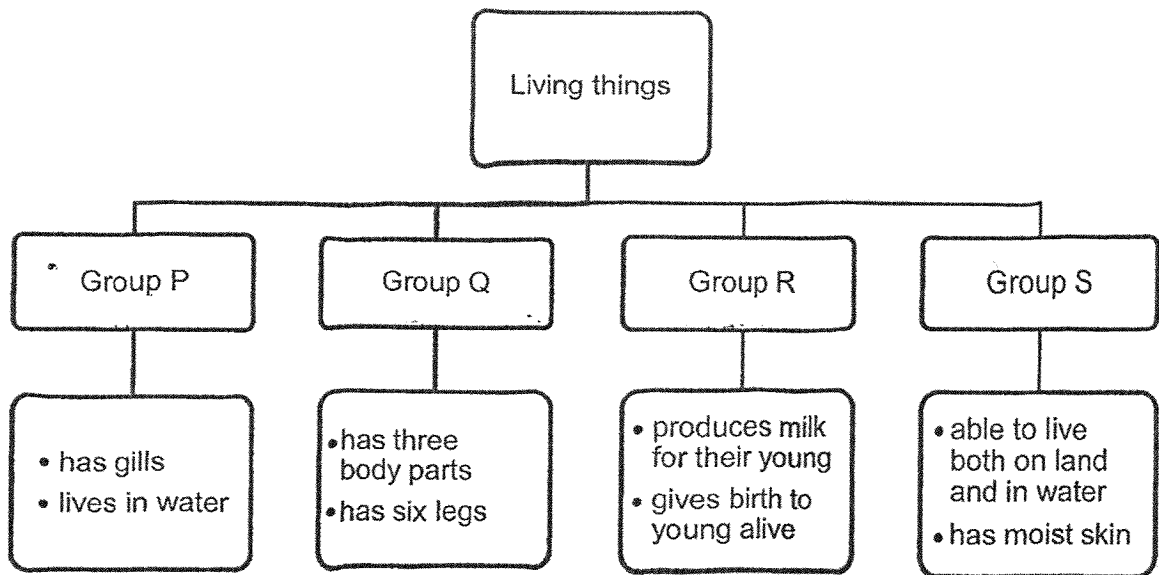

Which group should an amphibian be placed in?

- (1) P
- (2) Q
- (3) R
- (4) S

4 Which of the following statements about the function(s) of the small intestine is/are correct?

- A It digests food.
- B It absorbs water from the undigested food.
- C It absorbs digested food.
- D It pushes food into the stomach.

- (1) B only
- (2) C only
- (3) A and C only
- (4) A, C and D only

5 Which one of the following shows the correct order when food moves through some parts of the digestive system?

(1)

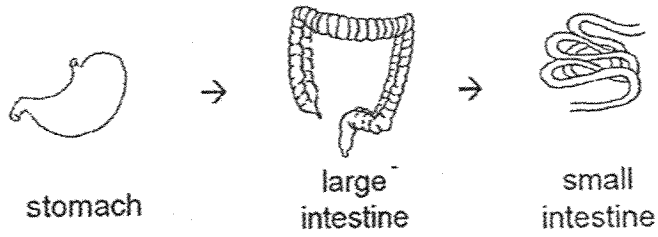

(2)

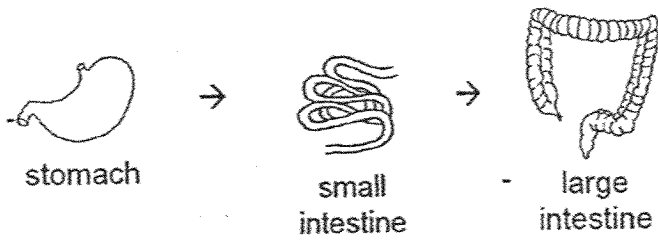

(3)

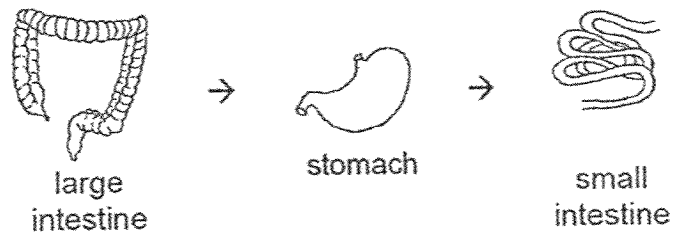

(4)

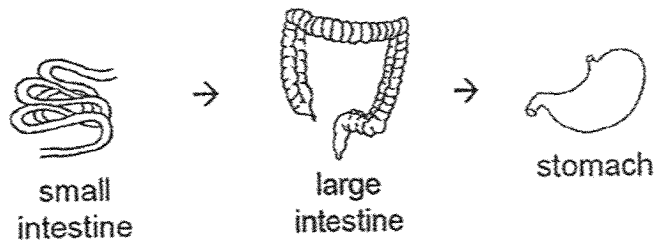

- 6 The diagram below shows how food travels through the different parts of the digestive system.

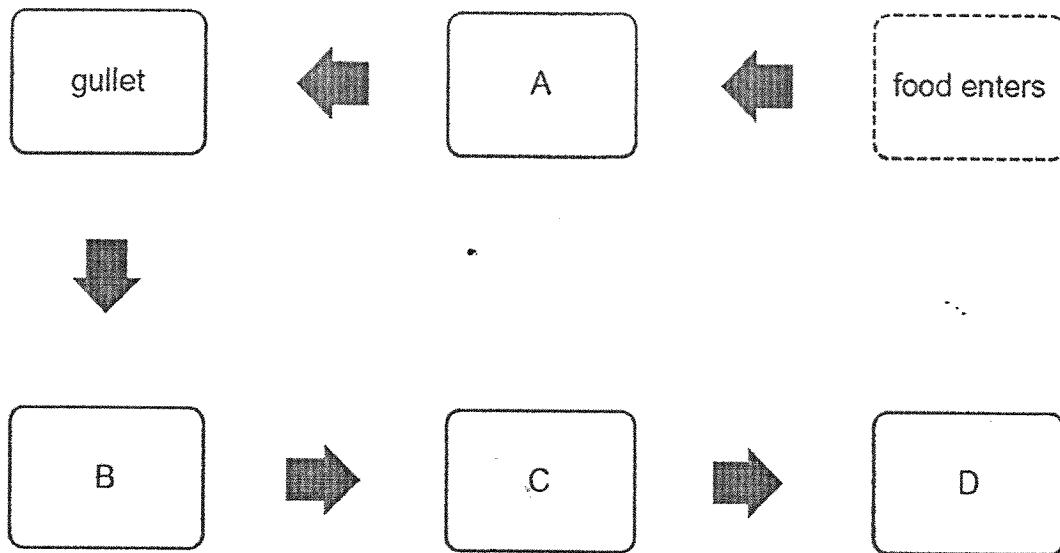

Which part(s), A, B, C or D show(s) where digestion takes place?

- (1) B only
  - (2) B and C only
  - (3) A, B, and C only
  - (4) A, B, C and D
- 7 Bala made the following observations on the life cycle of an animal.

- There are four stages in the life cycle.
- The young does not look like the adult.

Which animal was Bala observing?

- (1) Frog
- (2) Mosquito
- (3) Cockroach
- (4) Grasshopper

8 The diagram below shows a plant.

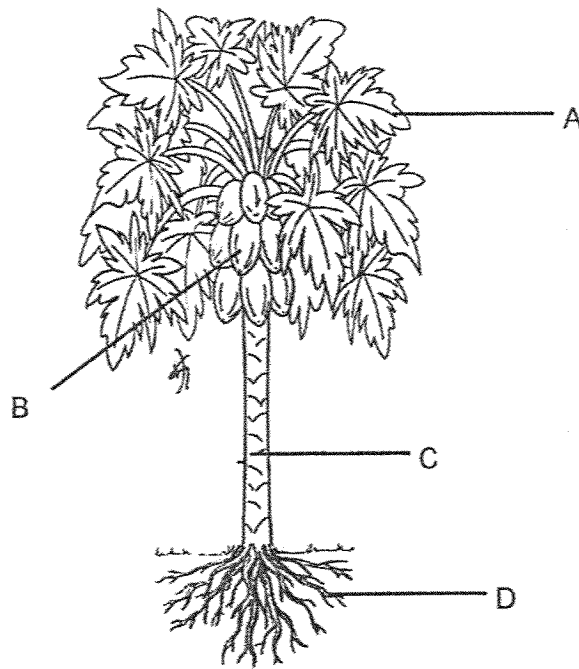

Which part of the plant A, B, C or D tells you that it is a flowering plant?

- (1) A
- (2) B
- (3) C
- (4) D

- 9 Lucy observed the life cycle of the butterfly and the beetle. She recorded the number of days in each stage of the life cycles below.

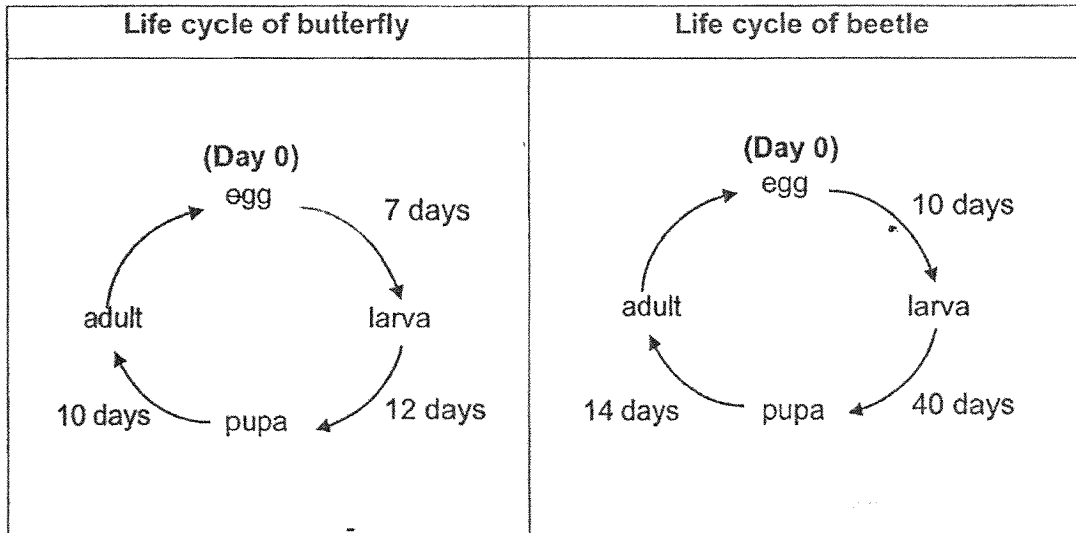

At which stage would each animal be on day 24?

	Stage in the life cycle on day 24	
	Butterfly	Beetle
(1)	egg	larva
(2)	larva	pupa
(3)	pupa	larva
(4)	pupa	pupa

- 10 Which one of the following is the function of a leaf on a plant?

- (1) hold the plant upright
- (2) makes food for the plant
- (3) transport water to the plant
- (4) hold the plant firmly to the soil

- 11 Gerald cut his plant at position X and transferred it from a pot to his garden as shown below. He also cut off some of its leaves. He watered the plant daily.

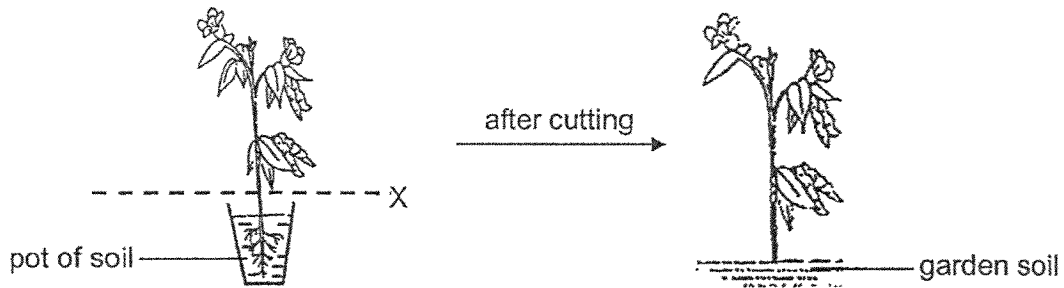

However, the plant died after a week. Which one of the following is most likely the reason why the plant died?

- (1) The plant has no fruit.
  - (2) The plant cannot stand upright.
  - (3) The plant cannot take in water and mineral salts.
  - (4) The plant is not getting enough sunlight to make food.
- 12 Siti wanted to find out if the amount of water given to a plant would affect the growth of the plant.

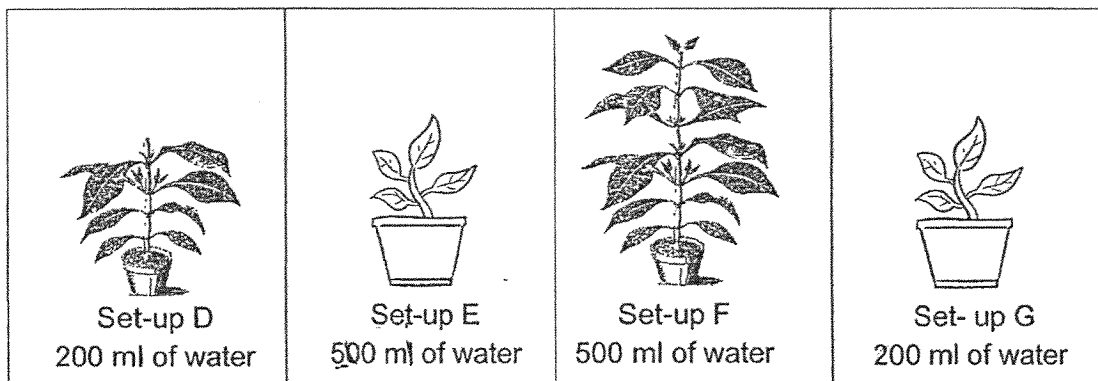

Which two set-ups should Siti use for her experiment?

- (1) D and F
- (2) D and G
- (3) E and F
- (4) E and G

13 Which of the following objects is made of a flexible material?

(1)

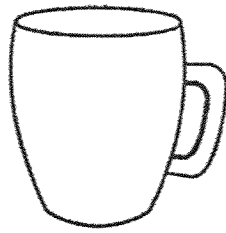

ceramic cup

(2)



glass bottle

(3)

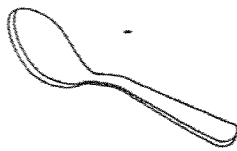

metal spoon

(4)

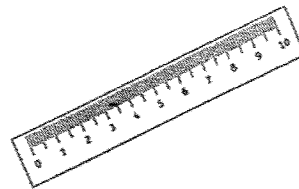

plastic ruler

- 14 Devi placed three similar cubes, P, Q and R, of the same size but made of different materials into three similar containers. Each container had 180 ml of water at first.

After three minutes, she took the cubes out and measured the amount of water left in the container. She recorded the results in the table below.

Cubes	Amount of water in the container (ml)	
	Before	After
P	180	100
Q	180	180
R	180	50

Which materials could the cubes P, Q, and R be made of?

	P	Q	R
(1)	metal	wood	fabric
(2)	wood	metal	fabric
(3)	fabric	wood	metal
(4)	wood	fabric	metal

- 15 James wanted to find out which material, W, X, Y or Z, was the strongest to make the lid of a pail.

He covered the pail using a lid made of material W. He added weights on the lid made of material W until it started to tear. He recorded the greatest weight that the lid could hold before it tore.

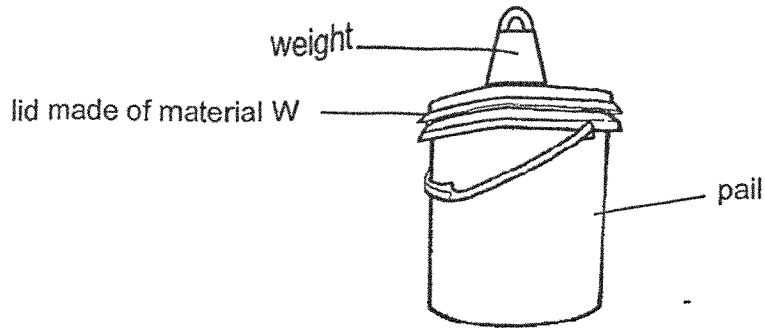

He repeated the experiment above using lids made of materials, X, Y and Z.

The graph below shows the weight each material of the lid could hold before it tore.

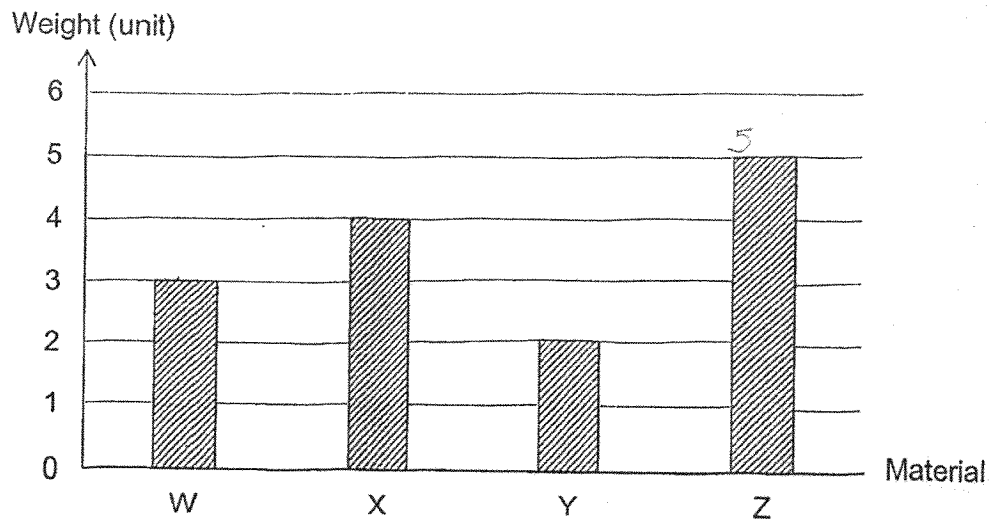

Which of the following statements is true?

- (1) Z is the weakest.
- (2) Y is the strongest.
- (3) X is stronger than Y.
- (4) Y is stronger than W.

16 The diagram shows a magnet brought near a plastic block.



What will happen to the plastic block?

- (1) It will move up.
- (2) It will not move.
- (3) It will move to the left.
- (4) It will move to the right.

17 Which one of the following will the two magnets push each other away?

(1)



(2)

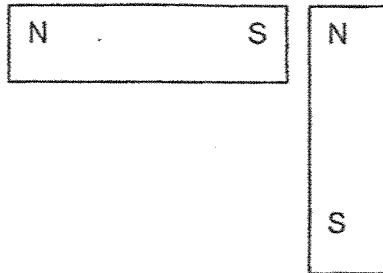

(3)

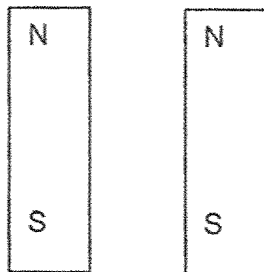

(4)

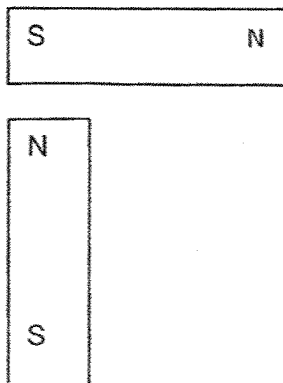

- 18 John placed magnets T, U and V near one another with a compass next to magnet V. Magnet T and U attracted each other but magnet U and magnet V repelled each other as shown below.

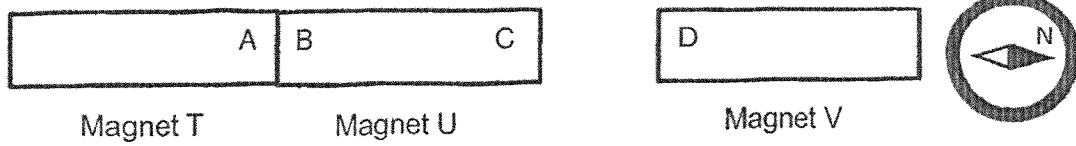

Which row shows the correct poles at A, B, C and D of the magnets?

	A	B	C	D
(1)	north	south	north	north
(2)	north	north	south	south
(3)	south	south	north	north
(4)	south	north	south	south

- 19 A bar magnet is lowered into a tray of iron pins as shown below. X, Y and Z are parts of the magnet.

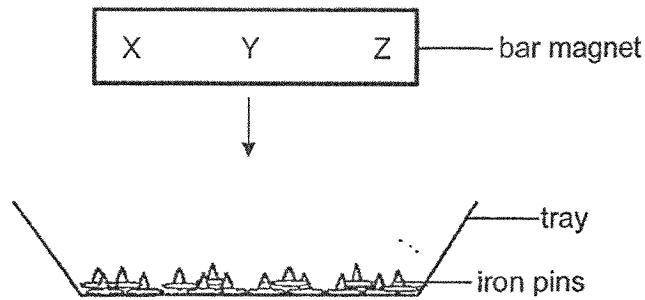

Which of the following shows the possible number of iron pins attracted to parts, X, Y and Z of the magnet?

Number of iron pins attracted			
	X	Y	Z
(1)	1	4	5
(2)	5	1	4
(3)	2	5	3
(4)	5	5	5

20 Study the diagram below.

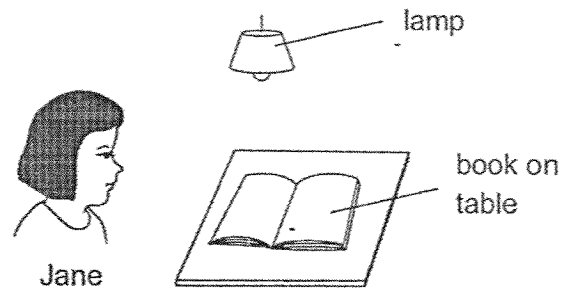

Which of the following explains why Jane can see the book on the table?

Key:



(1)

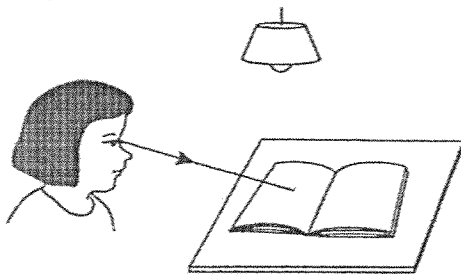

(2)

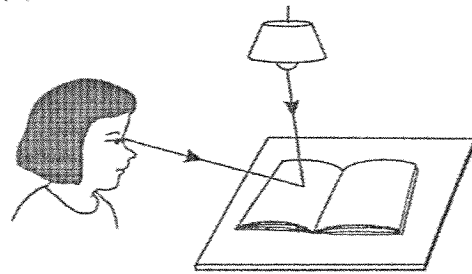

(3)

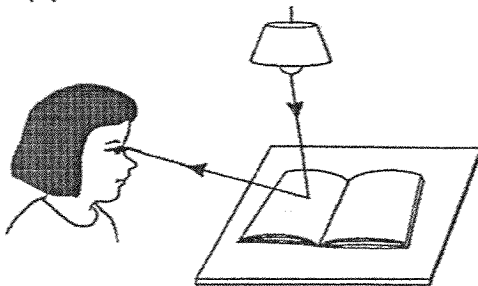

(4)

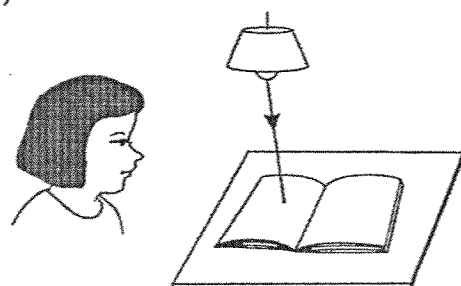

- 21 The diagram below shows the different positions of the shadow of a stick formed at different times, 8 a.m., 10 a.m., 2 p.m. and 5 p.m. of the day.

The Sun appears to be moving in the direction as shown by the arrow below from morning to evening.

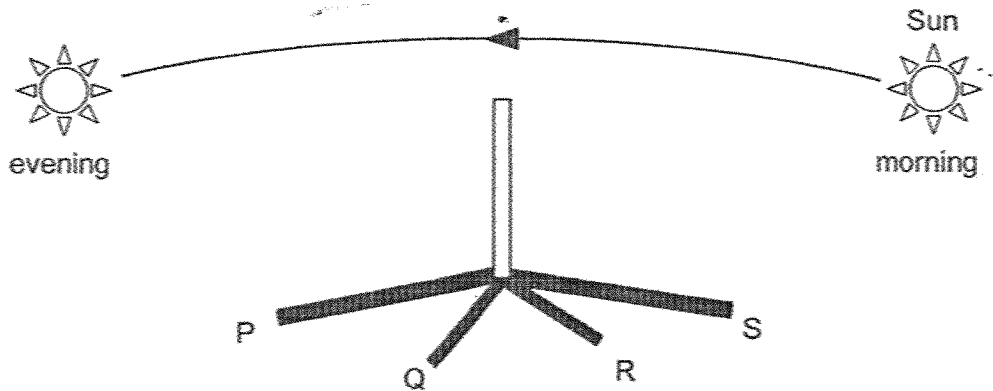

Which of the following positions is likely to be the shadow formed at 5 p.m. in the evening?

- (1) P
- (2) Q
- (3) R
- (4) S

22 An experiment was conducted to find out if light could pass through three sheets, A, B and C, made of different materials. The sheets were arranged in the two set-ups, X and Y, as shown below.

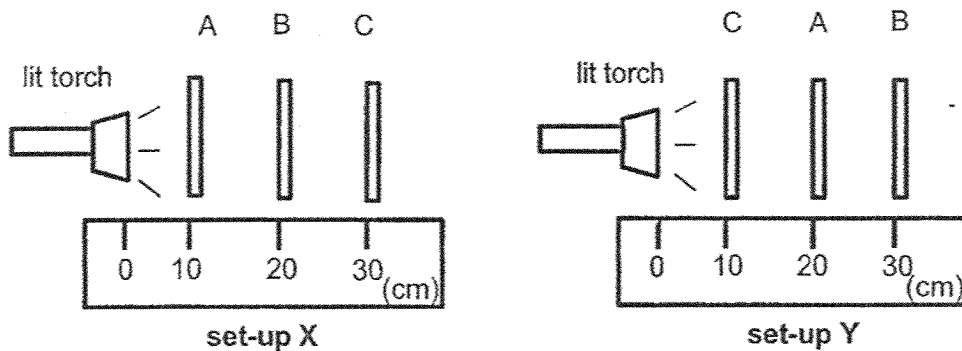

The maximum distance at which light could pass through the sheets in each set-up was measured and the results are shown in the graph below.

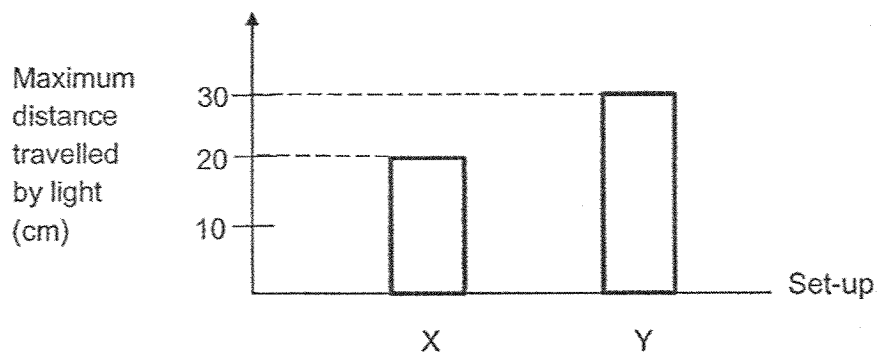

Which row correctly describes if light could pass through sheets A, B and C?

	Does the sheet allow light to pass through?		
	A	B	C
(1)	yes	yes	no
(2)	no	no	yes
(3)	yes	no	yes
(4)	no	yes	no

23 Which one of the following is **not** matter?

- (1) air
- (2) soil
- (3) water
- (4) lightning

24 The diagram below shows a small stone.

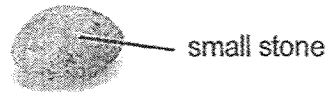

Which of the following can be used to measure the volume of the small stone?

(1)

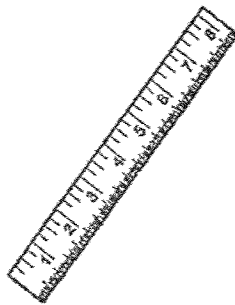

ruler

(2)

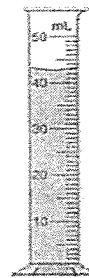

measuring cylinder with water

(3)

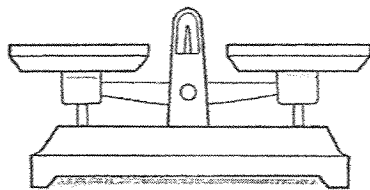

beam balance

(4)

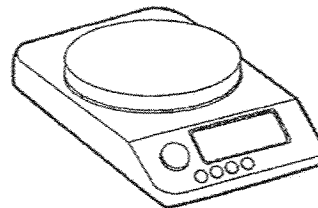

electronic balance

- 25 A bottle was filled with substance Y. It was then placed in different positions as shown in the diagram below.

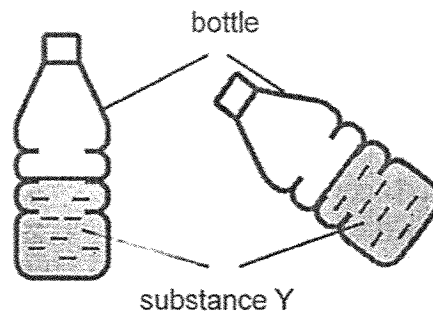

Which of the following statements is true about substance Y?

- (1) Substance Y is a gas.
  - (2) Substance Y is a solid.
  - (3) Substance Y is a liquid.
  - (4) Substance Y has no mass.
- 26 Which of the following about heat is true?
- (1) When an object loses heat, it contracts.
  - (2) Heat flows from a cooler place to a warmer place.
  - (3) When an object loses heat, its temperature increases.
  - (4) When an object gains heat, its temperature decreases.
- 27 Hot water at  $90\text{ }^{\circ}\text{C}$  is mixed with cold water at  $10\text{ }^{\circ}\text{C}$ .

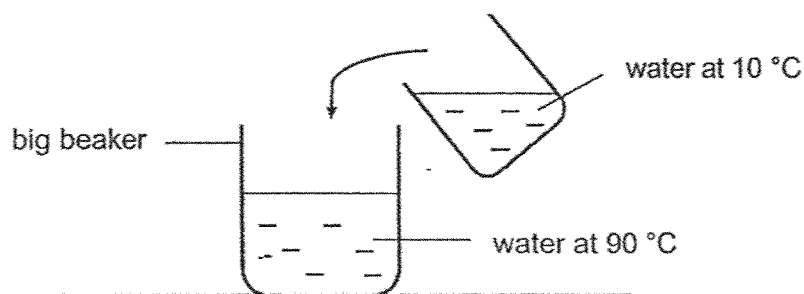

What is a possible final temperature of water in the big beaker?

- (1)  $10\text{ }^{\circ}\text{C}$
- (2)  $50\text{ }^{\circ}\text{C}$
- (3)  $90\text{ }^{\circ}\text{C}$
- (4)  $100\text{ }^{\circ}\text{C}$

- 28 Emily boiled some water and placed it in different containers made of materials W, X, Y and Z. She then measured the temperature of the water in each container over a period of time and recorded her results in the graph below.

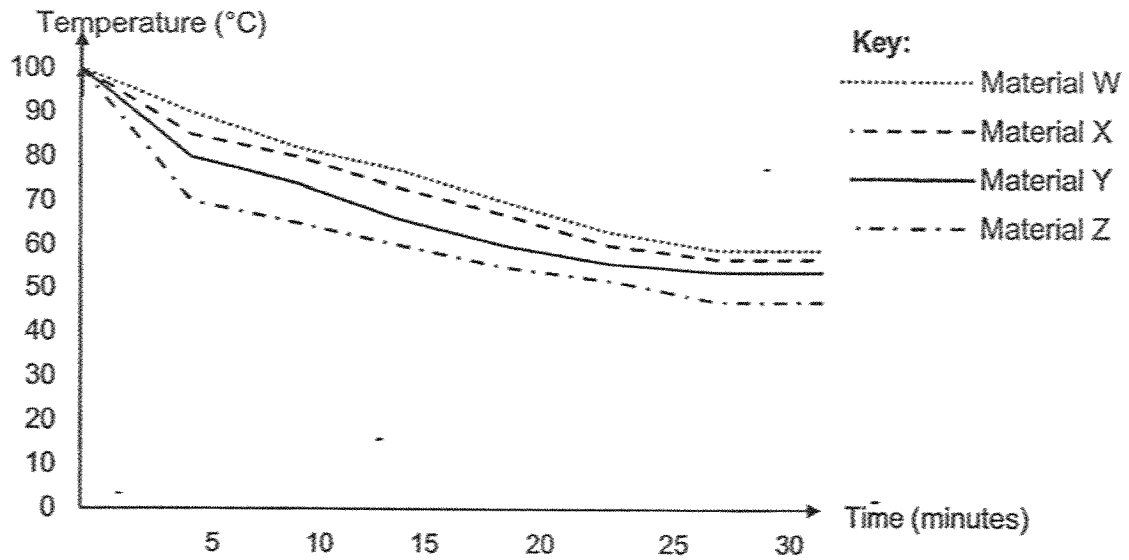

Based on the graph above, which material is the poorest conductor of heat?

- (1) W
- (2) X
- (3) Y
- (4) Z

Use the information below to answer Questions 29 and 30.

The diagram below shows a piece of cold butter on a warm toast. After half an hour, the piece of butter melted.

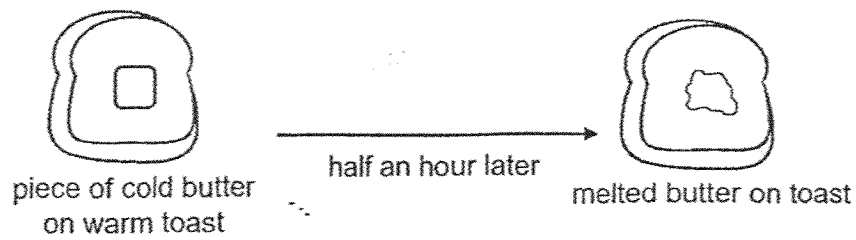

29 What is the change in state of matter when the butter melts?

- (1) Solid to liquid
- (2) Liquid to gas
- (3) Liquid to solid
- (4) Gas to liquid

30 Which of the following correctly explains why the piece of cold butter melted?

- (1) The cold butter lost heat to the warm toast.
- (2) The warm toast gained heat from the cold butter.
- (3) The cold butter gained heat from the warm toast.
- (4) The warm toast gained coldness from the cold butter.

End of Booklet A

(Go on to Booklet B)



**ST. HILDA'S PRIMARY SCHOOL  
END-OF-YEAR EXAMINATION, 2025**

**PRIMARY 4  
SCIENCE**

**Booklet B**

Name : \_\_\_\_\_ ( )      Class: Primary 4 / \_\_\_\_\_

Date: 22 October 2025

**Total Time for Booklets A and B: 1 hour 45 minutes**

**Parent's Signature:**

\_\_\_\_\_

**INSTRUCTIONS TO CANDIDATES**

1. Write your name, index number and class above.
2. Do not turn over this page until you are told to do so.
3. Follow all instructions carefully.
4. Answer all questions.
5. Use a pencil or dark blue or black ballpoint pen to write your answers in the space provided for each question.
6. Do not use correction fluid/tape.
7. Do not use highlighter on any part of your answers.

<b>Booklet</b>	<b>Maximum Marks</b>	<b>Marks Obtained</b>
<b>A</b>	<b>60</b>	
<b>B</b>	<b>40</b>	
<b>Total</b>	<b>100</b>	

This booklet consists of 13 printed pages.

For questions 31 to 40, write your answers in this booklet. The number of marks available is shown in brackets [ ] at the end of each question or part question.

(40 marks)

31 The diagram below shows some mushrooms.

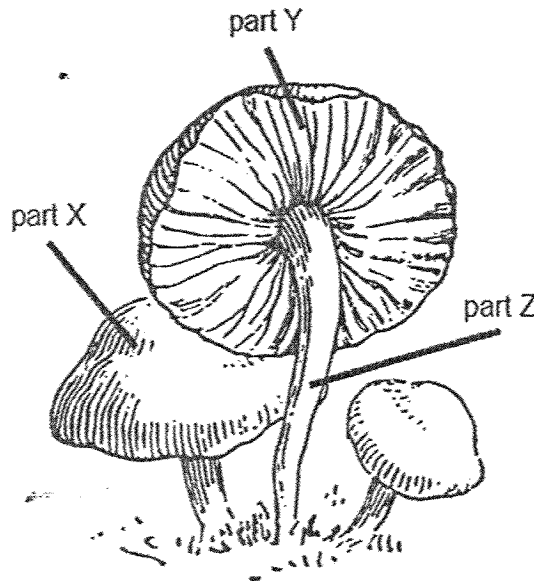

(a) At which part of the mushroom, X, Y or Z, are the spores found? [1]

\_\_\_\_\_

(b) Which of the following is true about fungi? Tick (✓) the correct answer. [1]

	Tick (✓)
All fungi are useful.	
Yeast is a type of fungi.	
Mould can make its own food.	
Mushrooms reproduce by spores.	

(Continues on next page)

SCORE	2
-------	---

Ruth observed some bracket fungi found on a rotten log. The bracket fungus is a type of fungi.

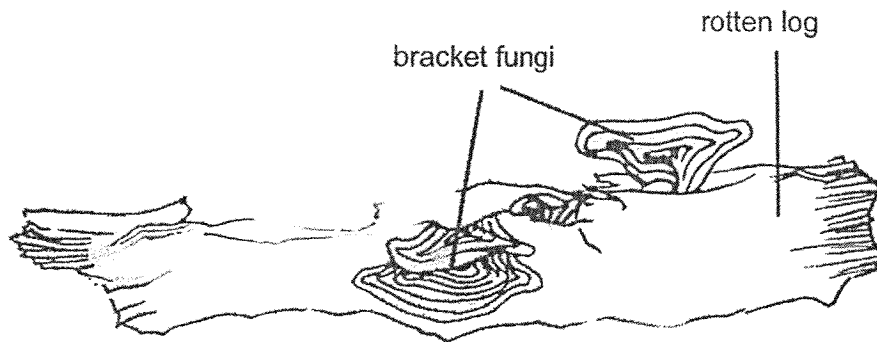

- (c) State where the bracket fungi get their food from. [1]

---

After a few days, Ruth returned to observe the bracket fungi. She observed that there were more of them on the log.

- (d) What characteristic of living things did the bracket fungi show? [1]

SCORE	2
-------	---

32 (a) Classify the following parts into the correct human systems. [3]

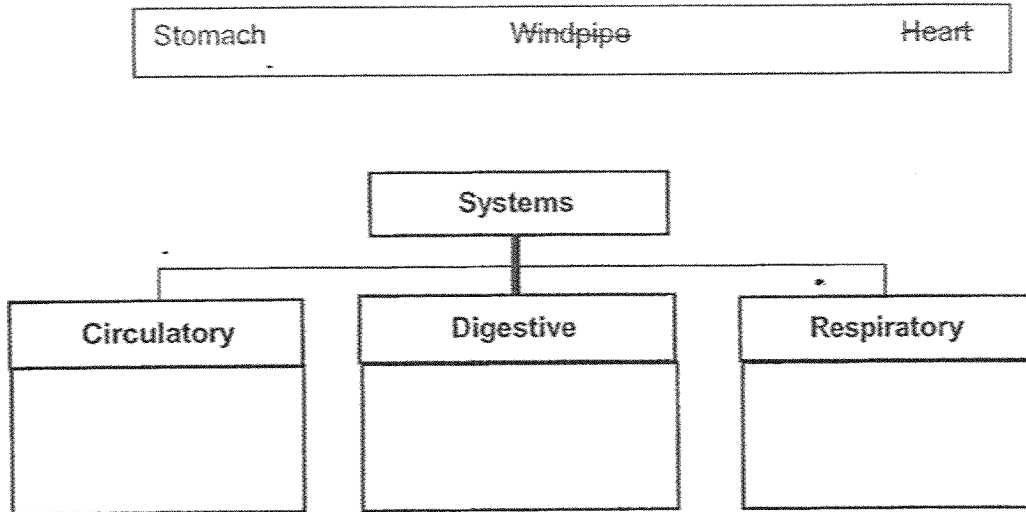

Ali set up the experiment below. He filled flask X and Y with equal amount of digestive juices. He then placed a piece of biscuit into flask X. He broke another similar biscuit into smaller pieces and placed them into flask Y. He then observed the amount of time it took for the biscuits of different sizes to be digested.

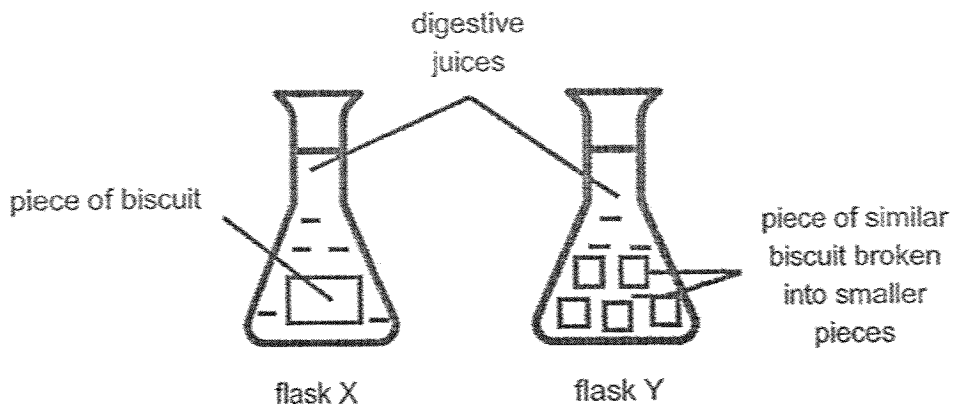

(b) State the aim of Ali's experiment. [1]

---



---

(c) Ali noticed that the biscuit broken into smaller pieces in flask Y were digested faster than flask X. Explain why. [1]

---



---

SCORE	5
-------	---

33. The diagram below shows two plants.

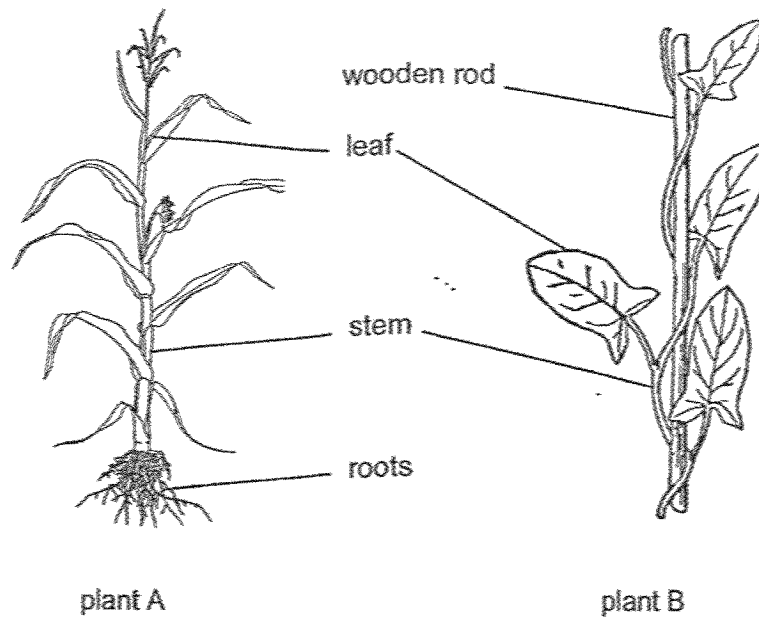

(a)(i) What is one difference between the stem of plant A and the stem of plant B? [1]

The stem of plant A is \_\_\_\_\_ than the stem of plant B.

(a)(ii) The roots of plant A absorb \_\_\_\_\_ from the soil. [1]

(b) Why does plant B need a wooden rod? [2]

---

---

---

SCORE	4
-------	---

34 Mrs Loh conducted an experiment in a dark room.

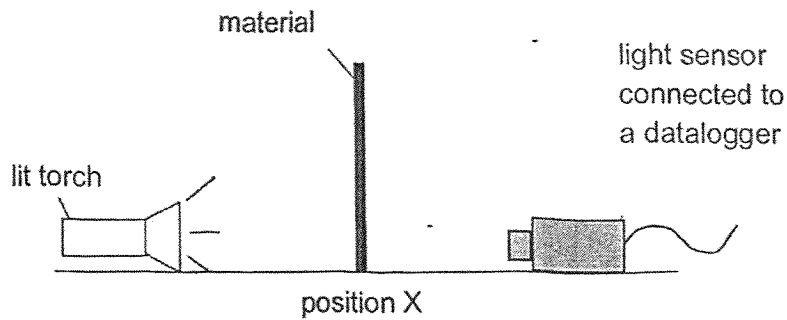

She placed materials, A, B and C, at position X, one at a time, and recorded the amount of light detected by the light sensor. She observed that when no material was placed at position X, the amount of light detected by the light sensor was 6000 units. Her results are shown below.

Materials	Amount of light detected by datalogger (units)
A	6000
B	0
C	800

(a) What are the variables that Mrs Loh should keep constant, changed and measured? Tick (✓) the correct answers. [2]

Variable	Constant	Changed	Measured
Type of material			
Amount of light detected			
Size of material			
Thickness of material			

(b) Which material, A, B or C, should be used to make the lens of a pair of spectacles? Explain your answer. [2]



---



---



---

SCORE	4
-------	---

35 Josiah set up an experiment to make an electromagnet as shown below.

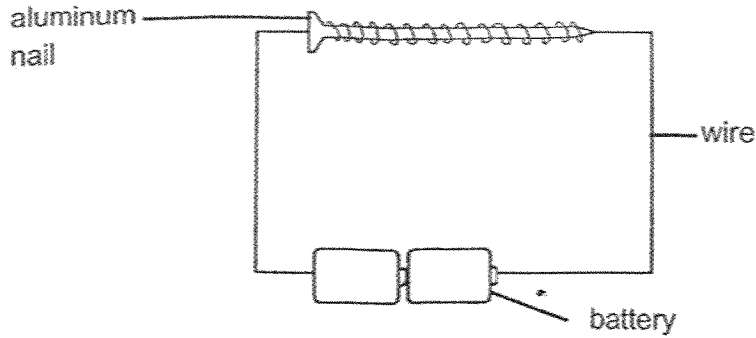

- (a) He used an aluminium nail for his set-up. However, he noticed that the aluminium nail could not attract any steel pins. Explain why. [2]

---



---

The diagram below shows a crane lifting a car using an electromagnet.

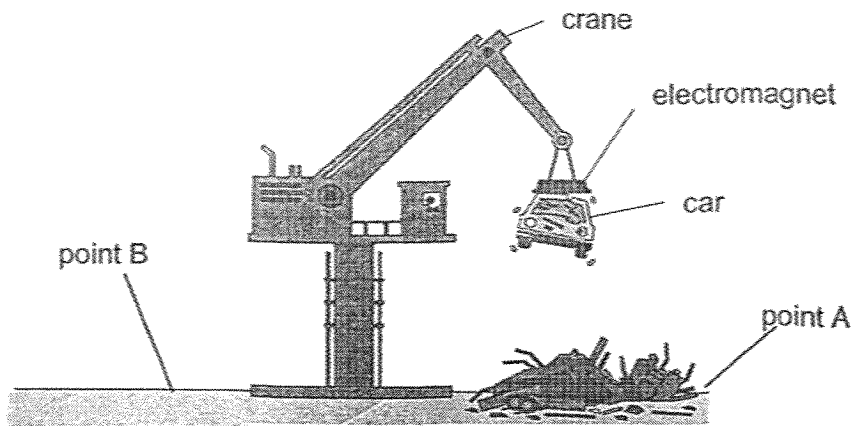

When the crane is switched on, the crane will lift the car up at point A and then move to point B. At point B, the crane is switched off and the car will be released.

- (b) Explain how the electromagnet was able to lift up the car at point A when the crane was switched on and then release it at point B when the crane was switched off? [2]

---



---



---

SCORE	4
-------	---

36 Study the diagrams below.

(a) Tick (✓) the sources of light.

[2]

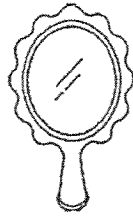

mirror



candle flame

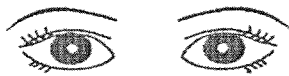

eyes

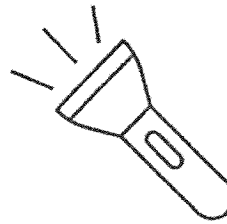

lit torch

(Continues on next page)

SCORE	2
-------	---

In a dark room, three sheets, A, B and C, made of different materials and shapes but of the same size were arranged randomly at position 1, 2 and 3 as shown below.

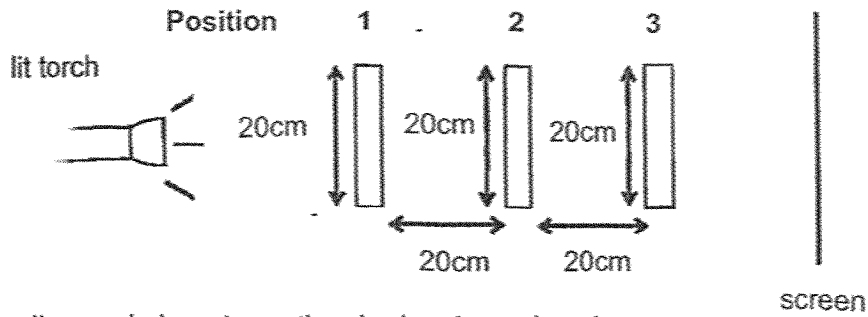

The diagram below shows the shadow formed on the screen.

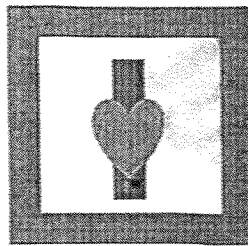

- (b) Based on the shadow formed on the screen, identify the position of the three sheets, A, B and C. [1]

Sheet	Shadow	Position (1, 2 or 3)
A		
B		
C		

- (c) Without moving the torch and screen, suggest one way to increase the size of the shadow formed by sheet A? [1]

SCORE	2
-------	---

37 Charles compared the mass of three fruits.

Study each of the diagrams below and circle the correct answers.

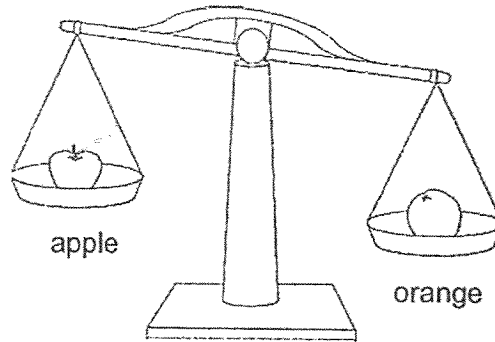

(a)(i) The orange ( *is heavier than / has the same mass as / is lighter than* ) the apple. [1]

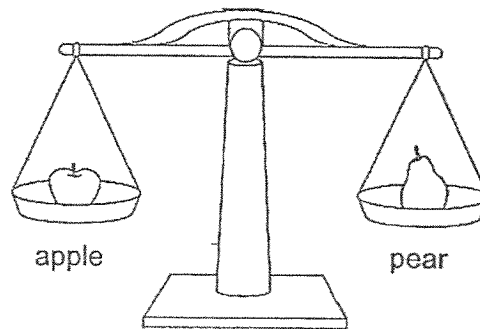

(a)(ii) The pear ( *is heavier than / has the same mass as / is lighter than* ) the apple. [1]

(b) State whether the following statements are true or false. Write "T" for True and "F" for false. [2]

	T / F
Shadow has no mass and does not occupy space.	
Two objects of the same volume can have different masses.	
A ball of clay does not have a definite shape because it can be reshaped.	
Water can take the shape of the container when it is poured in because water has no definite volume.	

SCORE	4
-------	---

- 38 Raj filled a syringe with air and some water as shown below. He sealed the nozzle and pushed the plunger in.

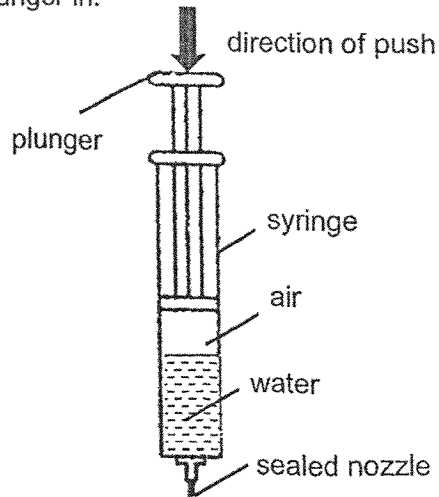

He noticed that the plunger was pushed in slightly.

- (a) Did air or the water allow the plunger to be pushed in? Explain your answer. [2]

---



---



---

A crow was seen dropping pebbles into a bottle of water in order to drink the water from the opening of the bottle.

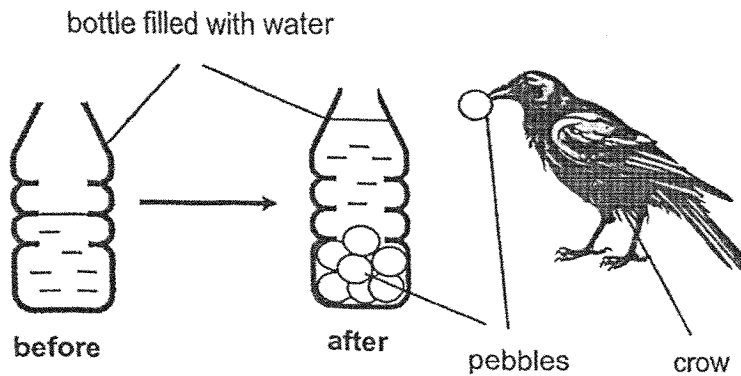

- (b) Explain how dropping the pebbles into the bottle will allow the crow to drink the water. [2]

---



---



---

SCORE	4
-------	---

39 The diagram below shows a metal pot on a stove.

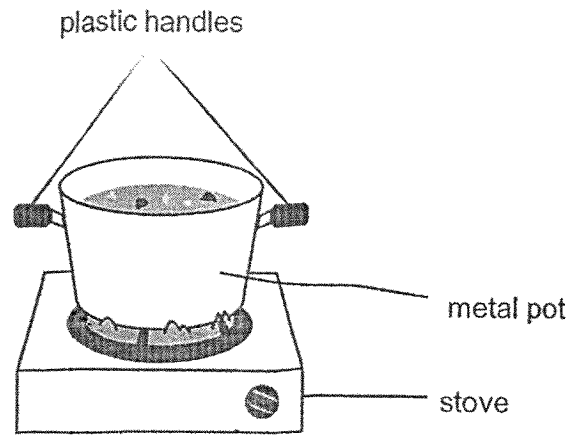

- (a)(i) The handles are made of plastic because it is a \_\_\_\_\_ [1]  
conductor of heat.
- (a)(ii) The pot is made of metal because it is a \_\_\_\_\_ conductor of [1]  
heat.

A polar bear's thick fur keeps it warm in the cold by trapping a layer of air between its skin and its surroundings.

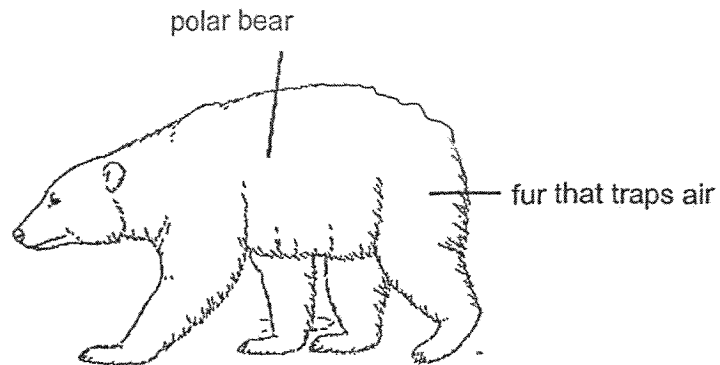

- (b) Explain how the trapped layer of air in the fur keeps the polar bear warm. [2]

---

---

---

SCORE	4
-------	---

- 40 Yusof had three rods of the same length but made of different materials X, Y and Z. He heated up the three rods for a fixed duration of time and then measured the length of the rods after heating. He recorded the results in the table below.

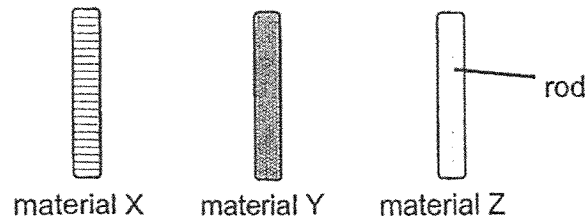

Material of rod	Original length of rod (cm)	Length of rod after heating (cm)
X	20	23
Y	20	21
Z	20	22

- (a) Which material, X, Y, or Z, expands the most? Explain your answer. [1]

---



---

Yusof was crossing a metal bridge when he noticed that there were some gaps at the two ends of the metal bridge.

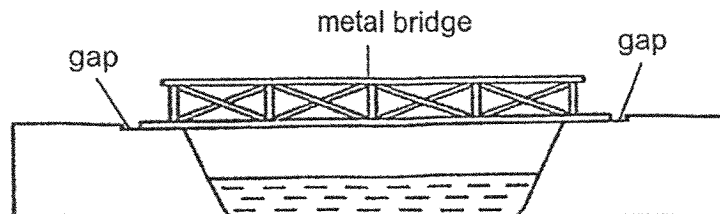

- (b) Explain why the gaps were needed at the two ends of the metal bridge on a hot day. [2]

---



---



---

END OF PAPER

SCORE	3
-------	---

[www.sgexam.com](http://www.sgexam.com)

**SCHOOL : ST HILDA'S PRIMARY SCHOOL**  
**LEVEL : PRIMARY 4**  
**SUBJECT : SCIENCE**  
**TERM : 2025 END OF YEAR EXAMINATION**

Q1	Q2	Q3	Q4	Q5	Q6	Q7	Q8	Q9	Q10
3	1	4	3	2	3	2	2	3	2
Q11	Q12	Q13	Q14	Q15	Q16	Q17	Q18	Q19	Q20
3	4	4	2	3	2	3	4	2	3
Q21	Q22	Q23	Q24	Q25	Q26	Q27	Q28	Q29	Q30
4	3	4	2	2	1	2	1	1	3

31(a)	Part Y																				
31(b)	Yeast is a useful fungi. ✓ Mushrooms reproduce by spores. ✓																				
31(c)	The rotten log / wood / dead tree trunk																				
31(d)	Living things can reproduce.																				
32(a)	<b>Systems</b> Circulatory → heart Digestive → stomach Respiratory → windpipe																				
32(b)	To find out if the <b>surface area of the biscuit in contact with digestive juices</b> affects the <b>rate of digestion</b> .																				
32(c)	The smaller biscuit pieces had a <b>larger surface area</b> in contact with the digestive juices.																				
33(ai)	Stronger																				
33(aii)	Water / mineral salt																				
33(b)	Plant B has a <b>weak stem</b> . The rod <b>provides support</b> for the stem to hold the leaves up so that the leaves can get <b>more light to make more food</b> .																				
34(a)	<table border="1"> <thead> <tr> <th>Variable</th><th>Constant</th><th>Changed</th><th>Measured</th></tr> </thead> <tbody> <tr> <td>Type of material</td><td></td><td>✓</td><td></td></tr> <tr> <td>Amount of light detected</td><td></td><td></td><td>✓</td></tr> <tr> <td>Size of material</td><td>✓</td><td></td><td></td></tr> <tr> <td>Thickness of material</td><td>✓</td><td></td><td></td></tr> </tbody> </table>	Variable	Constant	Changed	Measured	Type of material		✓		Amount of light detected			✓	Size of material	✓			Thickness of material	✓		
Variable	Constant	Changed	Measured																		
Type of material		✓																			
Amount of light detected			✓																		
Size of material	✓																				
Thickness of material	✓																				
34(b)	<b>C:</b> Material A <b>E:</b> The amount of light detected by the datalogger is the <b>greatest</b> .																				

	<b>R:</b> It allows the <b>most light to pass through / is transparent</b> . <b>U:</b> This will allow the user to <b>see clearly</b> when they wear the spectacles.
35(a)	Aluminium is a <b>non-magnetic material</b> so it <b>cannot be magnetised</b> .
35(b)	The car is made of <b>magnetic material</b> that can be <b>attracted by the electromagnet</b> at point A. When the crane moves to point B, the electromagnet <b>loses its magnetism / is demagnetised</b> , so the car will <b>not be attracted</b> and will fall.
36(a)	Candle flame Lit torch
36(b)	A – Position 1 B – Position 3 C – Position 2
36(c)	Move sheet A <b>nearer</b> to the torch.
37(ai)	The orange <b>is heavier than</b> the apple.
37(aii)	The pear <b>has the same mass as</b> the apple.
37(b)	<ul style="list-style-type: none"> <li>• Shadow has no mass and does not occupy space – <b>True</b></li> <li>• Two objects of the same volume can have different masses – <b>True</b></li> <li>• A ball of clay does not have a definite shape – <b>False</b></li> <li>• Water can take the shape of the container because water has no definite volume – <b>False</b></li> </ul>
38(a)	Air. Air <b>can be compressed</b> while water <b>cannot be compressed</b> .
38(b)	The pebble <b>occupies space</b> in the water. The pebbles will <b>increase the water level</b> , which allows the crow to drink.
39(ai)	Poor
39(aii)	Good
39(b)	Air (trapped in the fur) is a <b>poor conductor of heat</b> , so the polar bear will <b>lose heat slower</b> to the surroundings.
40(a)	<b>X</b> . The rod made of material X <b>increased the most in length</b> .
40(b)	On a hot day, the metal bridge will <b>gain heat from the surroundings and expand</b> . The gaps provide space for the bridge to expand, so the metal bridge will <b>not break</b> .