

Henry Park Primary School
Primary Four Science
2025 Weighted Assessment 1

Name: _____ () Class: 4 () Parent's Signature: _____

Booklet A (14 marks)

Marks: _____ / 25

For each question from 1 to 7, four options are given. One of them is the correct answer.
Make your choice (1, 2, 3 or 4) and write the answers in the boxes given below.

Q1	Q2	Q3	Q4	Q5	Q6	Q7

1 Which of the following animals is a reptile?

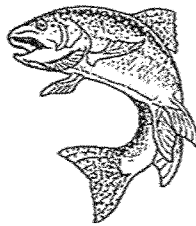

(1)

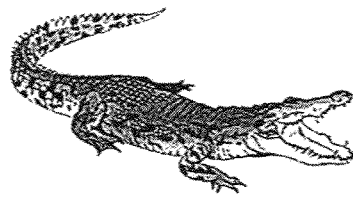

(2)



(3)

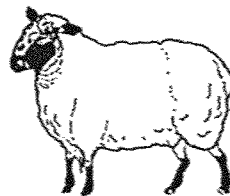

(4)

2 Which of the following are characteristics of insects?

- A They have six legs.
- B They have six body parts.
- C They have a hard outer covering.

- (1) A and B only
- (2) A and C only
- (3) B and C only
- (4) A, B and C

3 Which of the following animals have a 4-stage life cycle?

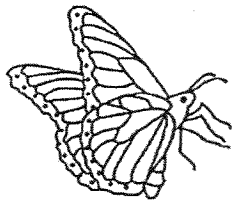

A



B

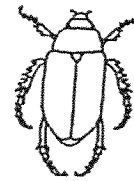

C

- (1) A and B only
- (2) B and C only
- (3) A and C only
- (4) A, B and C

4 Which part of the plant, P, Q, R, or S, helps the plant to make food?

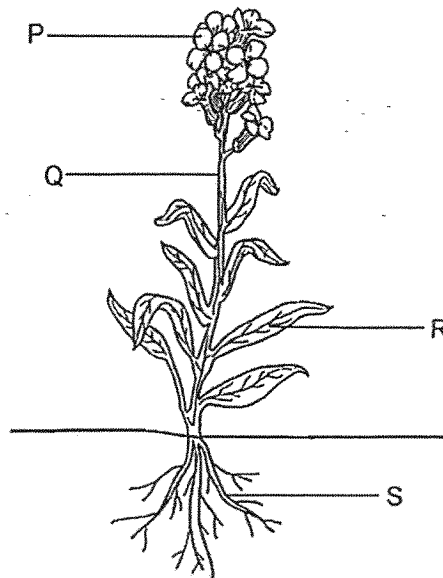

- (1) P
- (2) Q
- (3) R
- (4) S

5 Study the flow chart below.

Three animals have been classified based on their characteristics.

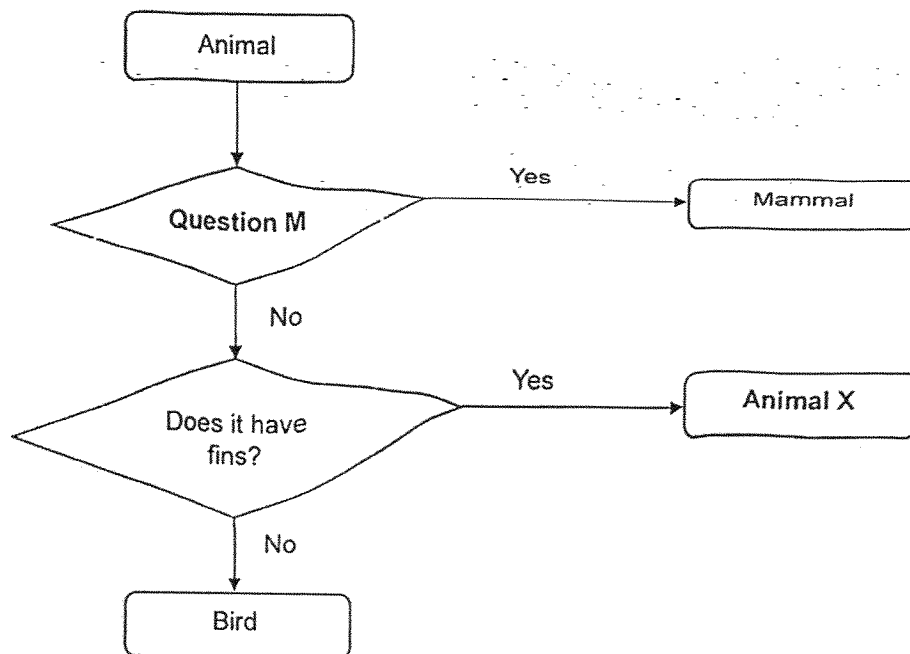

Based on the flowchart given, which of the following is correct?

	Question M	Animal X
(1)	Does it lay eggs?	Amphibian
(2)	Does it breathe through gills?	Reptile
(3)	Does it breathe through lungs?	Insect
(4)	Does it give birth to its young alive?	Fish

- 6 Mrs. Tan used a metal spoon to stir her hot Milo as shown below.

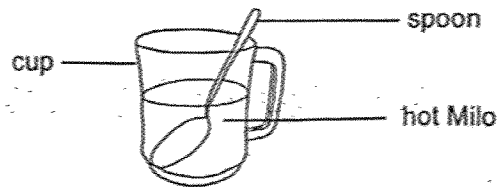

The spoon became hot after a while.

Which of the following explains this?

- (1) The spoon lost heat to the hot Milo.
- (2) The spoon gained heat from the cup.
- (3) The spoon gained heat from the hot Milo.
- (4) The spoon gained heat from the surrounding air.

7 The diagram shows a wooden ball and a plastic ball on both ends of a lever balance.

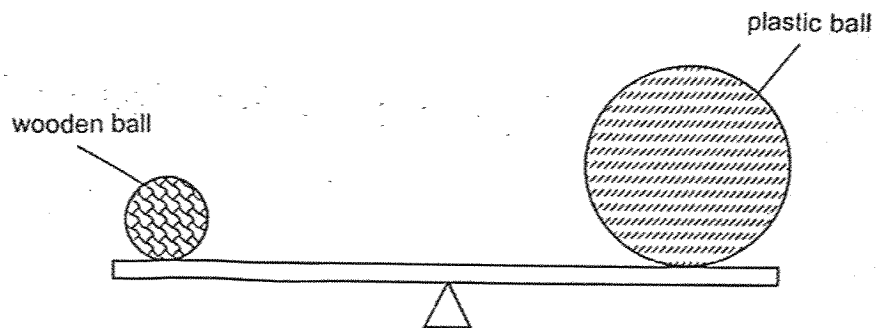

Based on the diagram, we can conclude that the wooden ball and the plastic ball have _____.

- (1) the same mass and volume
- (2) different mass and different volume
- (3) the same mass but different volume
- (4) different mass but the same volume

Henry Park Primary School
Primary Four Science
2025 Weighted Assessment 1

Name: _____ () Class: 4 _____

Booklet B (11 marks)

For questions 8 to 12, write your answers in the space provided.

The number of marks available is shown in brackets [] at the end of each question or part question.

8 Classify the following into matter and non-matter. [2]

heat	milk	pebble	shadow
------	------	--------	--------

Matter	Non-Matter

- 9 The diagram below shows a thermometer in a beaker of water in a room. The room temperature is 31°C.

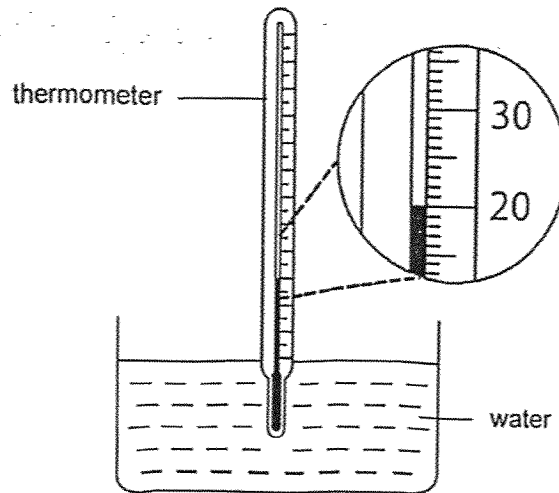

- (a) What is the reading on the thermometer? [1]

The beaker of water was left in the room for 2 hours.

- (b) State the temperature of the water after 2 hours. [1]

- (c) Give a reason for your answer in part (b). [1]

- 10 Maureen poured coloured water into each of the glass containers shown below until the water reached the same level. She observed the shape of the coloured water in each container.

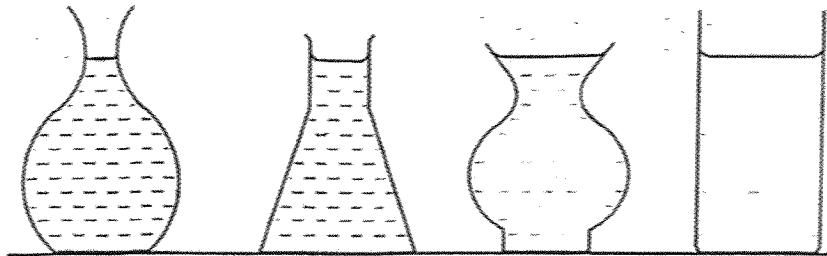

State two properties of liquids observed by Maureen.

[2]

- (i) _____
(ii) _____

- 11 Kiran placed a plant into a flask with water and placed it in her room as shown below. She observed the water level in the flask two hours later.

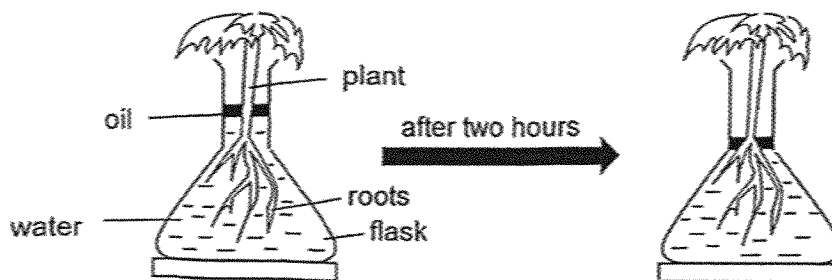

State what happened to the amount of water in the flask after two hours. Give a reason for your answer.

[2]

- 12 Jill carried out an experiment with some plasticine. She gently lowered a piece of plasticine into a beaker of water as shown below. X shows the water level after the plasticine is placed inside the beaker.

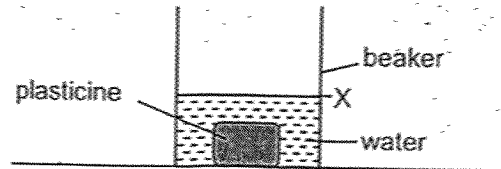

She took the plasticine out and reshaped it before gently lowering it back into the same beaker as shown in the diagram below. No water was spilled in the process.

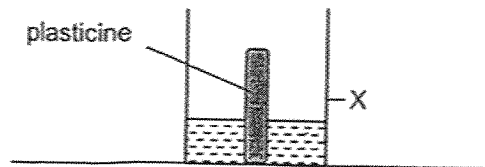

She observed that the water level dropped and concluded that the volume of plasticine has decreased.

Do you agree with her? Explain why.

[2]

End of Weighted Assessment 1

SCHOOL : HENRY PARK PRIMARY SCHOOL
LEVEL : PRIMARY 4
SUBJECT : SCIENCE
TERM : 2025 WEIGHTED ASSESSMENT 1

Q1	2
Q2	2
Q3	3
Q4	3
Q5	4
Q6	3
Q7	3
Q8	Matter – milk, pebble Non-Matter – heat, shadow
Q9	a) 20°C b) 31°C c) The water gained heat from the surrounding air until it reached the room temperature.
Q10	i) Liquids have a definite volume. ii) Liquids do not have a definite shape.
Q11	The amount of water decreased. The roots of the plant took in some water.
Q12	No. The water level dropped as only part of the plasticine is taking up space in the water.

www.sgexam.com