



Nan Hua Primary School
Primary 4 Science
Term 2 Weighted Assessment 2025

| Marks | |
|---------------|-------------|
| Section A: | / 10 |
| Section B: | / 10 |
| Total: | / 20 |

Name: _____ ()

Class: Primary 4S _____

Date: _____

Duration: 30 minutes

Parent's Signature

Answer all questions

Section A: (5 x 2 marks = 10 marks)

For each question from 1 to 5, four options are given. One of them is the correct answer. Make your choice (1, 2, 3 or 4) and write your answer in the brackets provided.

1 Ali wants to find the volume of a stone. He is given the items shown below.

(A)

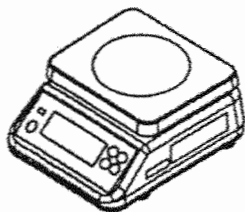

electronic balance

(B)

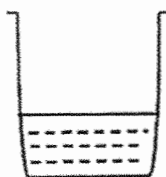

container of water

(C)



measuring cylinder

Which item(s) should Ali use to measure the volume of the stone?

- (1) A only
- (2) B only
- (3) B and C only
- (4) A, B and C

2 Which one of the following is not matter?

- (1) ice
- (2) oil
- (3) light
- (4) mushroom

()

3 Study the flow chart.

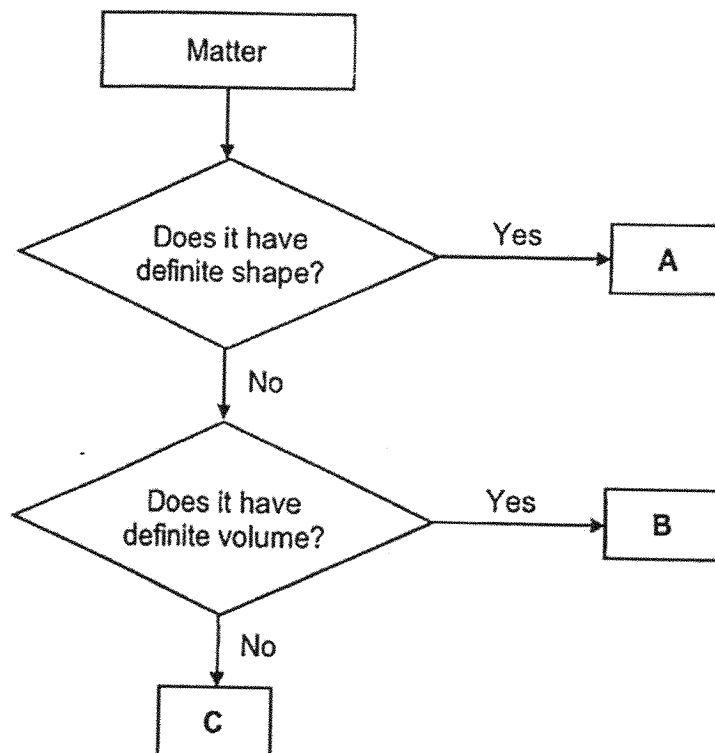

Which of the following correctly represents A, B and C?

| | A | B | C |
|-----|--------|--------|--------|
| (1) | air | milk | marble |
| (2) | milk | marble | air |
| (3) | marble | air | milk |
| (4) | marble | milk | air |

- 4 Object X and object Y were placed on a lever balance. The pans were balanced as shown.

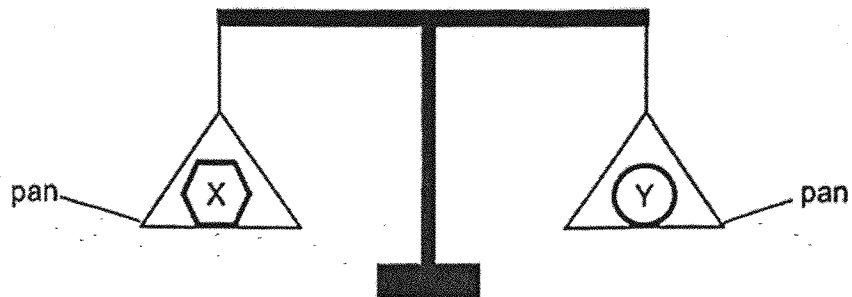

The pans were balanced because objects X and Y have _____.

- (1) equal mass
 - (2) equal volume
 - (3) definite shape
 - (4) definite volume ()
- 5 The diagram below shows a sealed metal box containing 160 cm³ of water and 80 cm³ of air at first. Then 20 cm³ of water and 20 cm³ of air were pumped in.

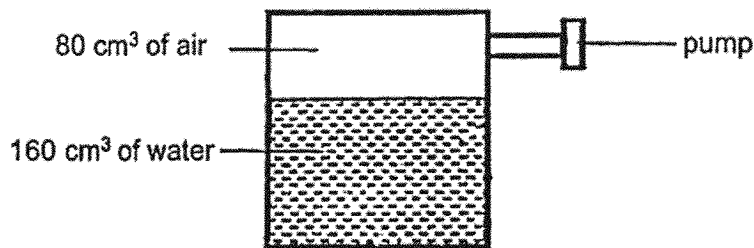

How would the final volume and mass of water and air in the box change?

| | Volume of water | Volume of air | Mass of water | Mass of air |
|-----|-----------------|-----------------|---------------|-------------|
| (1) | decrease | remain the same | decrease | increase |
| (2) | increase | increase | increase | increase |
| (3) | increase | decrease | increase | decrease |
| (4) | increase | decrease | increase | increase |

()

Section B: Structured questions (10 marks)

For questions 6 to 8, write your answers in the space provided. The number of marks available is shown in brackets [] at the end of each question or part question.

6 (a) State what matter is.

[1]

Susan filled a container to its brim with 150 cm^3 of pebbles as shown below.

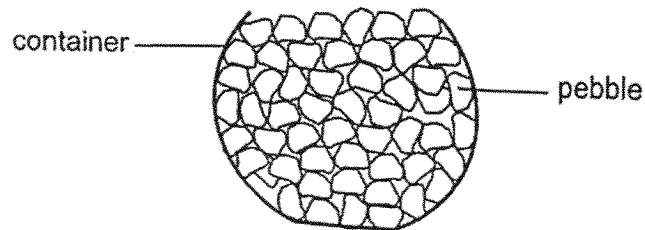

(b) Identify the state(s) of matter found in the container.

[1]

(c) Tick (✓) the box that shows the most likely volume of the container.

[1]

| Volume of Container | Tick (✓) the correct volume |
|------------------------------|-------------------------------|
| Less than 150 cm^3 | |
| Equals to 150 cm^3 | |
| More than 150 cm^3 | |

| | |
|-------|---|
| SCORE | 3 |
|-------|---|

(Go on to the next page)

- 7 Sam put a piece of plasticine into a beaker of water. The water level of the beaker rose to 300 ml. He took the plasticine out of the beaker and cut it into four smaller pieces. The four smaller pieces were then put back into the beaker of water.

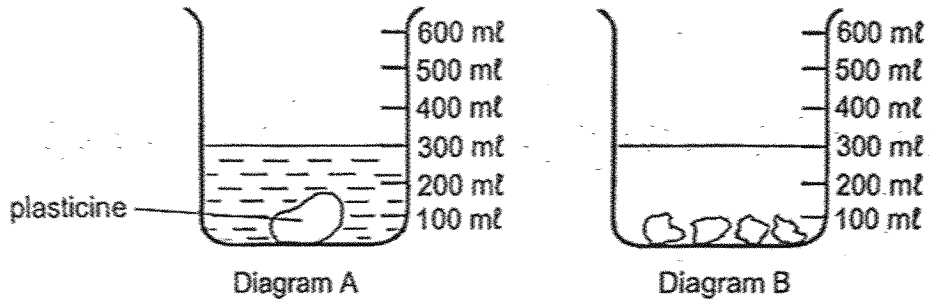

- (a) Draw a line in Diagram B to show the water level after the four smaller pieces of plasticine were put back into the beaker of water. [1]

Sam conducted another experiment. He put two objects, P and Q, of different sizes into two identical empty beakers. He then poured water into both beakers to the same level as shown below.

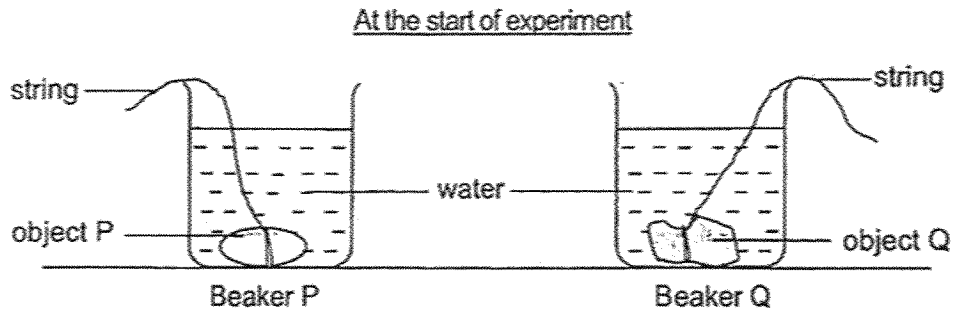

- (b) Without using any other apparatus, what could Sam do to find out which object has a bigger volume? [1]

- (c) Based on your answer in (b), what observation would Sam make if object P has a bigger volume? [1]

| | |
|-------|---|
| SCORE | 3 |
|-------|---|

(Go on to the next page)

- 8 Ravi pushed a deflated balloon into a plastic bottle and folded the edge of the balloon over the opening of the plastic bottle.

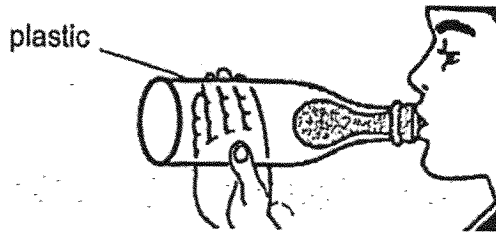

- (a) When he blew the balloon, he found it difficult, and he could only inflate the balloon a little. Explain why. [1]

- (b) Ravi then made some holes at the side of the plastic bottle. He realised that it was easier to blow the deflated balloon. Explain why it was easier to blow the balloon. [2]

- (c) Ravi was curious to find out if the size of the bottle affects the size of the inflated balloon.

Put a tick (✓) in the boxes below to show the variable(s) that Ravi must keep the same to conduct a fair test. [1]

| Variable | Keep the same (✓) |
|--------------------------|-------------------|
| Size of bottle | |
| Size of inflated balloon | |
| Size of deflated balloon | |

End of Paper

| | |
|-------|---|
| SCORE | 4 |
|-------|---|

SCHOOL : NAN HUA PRIMARY SCHOOL
LEVEL : PRIMARY 4
SUBJECT : SCIENCE
TERM : 2025 WEIGHTED ASSESSMENT 2

| 1 | 3 | | | | | | | | |
|-------------------------------|--|---------------------|-------------------------------|-------------------------------|--|-------------------------------|--|-------------------------------|---|
| 2 | 3 | | | | | | | | |
| 3 | 4 | | | | | | | | |
| 4 | 1 | | | | | | | | |
| 5 | 4 | | | | | | | | |
| 6a | Matter is anything that has mass and occupies space . | | | | | | | | |
| 6b | solid and gas | | | | | | | | |
| 6c | <table border="1"> <thead> <tr> <th>Volume of Container</th> <th>Tick (✓) the correct volume</th> </tr> </thead> <tbody> <tr> <td>Less than 150 cm³</td> <td></td> </tr> <tr> <td>Equals to 150 cm³</td> <td></td> </tr> <tr> <td>More than 150 cm³</td> <td style="text-align: center;">✓</td> </tr> </tbody> </table> | Volume of Container | Tick (✓) the correct volume | Less than 150 cm ³ | | Equals to 150 cm ³ | | More than 150 cm ³ | ✓ |
| Volume of Container | Tick (✓) the correct volume | | | | | | | | |
| Less than 150 cm ³ | | | | | | | | | |
| Equals to 150 cm ³ | | | | | | | | | |
| More than 150 cm ³ | ✓ | | | | | | | | |
| 7a | Draw a line at 300 ml. | | | | | | | | |
| 7b | Remove both objects and check which beaker has less water. | | | | | | | | |
| 7c | The water level in beaker P was lower. | | | | | | | | |
| 8a | There is air in the bottle and air occupies space. | | | | | | | | |
| 8b | The air in bottle can escape through the holes. So balloon can inflate as it can occupy the space previously occupied by the air that escaped. | | | | | | | | |
| 8c | <table border="1"> <thead> <tr> <th>Variable</th> <th>Keep the same (✓)</th> </tr> </thead> <tbody> <tr> <td>Size of bottle</td> <td></td> </tr> <tr> <td>Size of inflated balloon</td> <td></td> </tr> <tr> <td>Size of deflated balloon</td> <td style="text-align: center;">✓</td> </tr> </tbody> </table> | Variable | Keep the same (✓) | Size of bottle | | Size of inflated balloon | | Size of deflated balloon | ✓ |
| Variable | Keep the same (✓) | | | | | | | | |
| Size of bottle | | | | | | | | | |
| Size of inflated balloon | | | | | | | | | |
| Size of deflated balloon | ✓ | | | | | | | | |

www.sgexam.com