



**NANYANG PRIMARY SCHOOL  
END-OF-YEAR EXAMINATION  
2025**

**PRIMARY 5**

**SCIENCE  
(BOOKLET A)**

Total Time for Booklets A and B: 1 hour 45 minutes

Additional materials: Optical Answer Sheet (OAS)

**INSTRUCTIONS TO CANDIDATES**

1. Write your name and index number in the space provided.
2. Do not turn over this page until you are told to do so.
3. Follow all instructions carefully.
4. Answer all questions.
5. Use a 2B pencil to shade your answers on the Optical Answer Sheet (OAS).

Name: \_\_\_\_\_ (      )

Class: Primary 5 (      )

This booklet consists of 21 printed pages and 0 blank page(s).

Section A: Multiple Choice Questions [60 marks]

1. The diagrams below show parts of the human reproductive system.

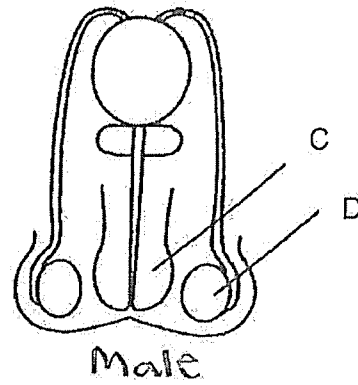
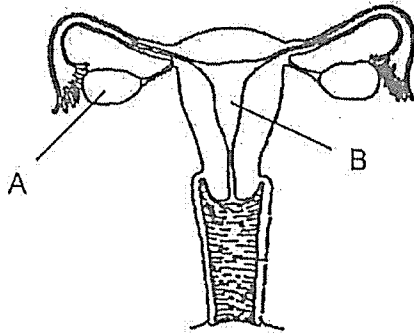

In which of the parts, A, B, C or D, does a fertilised egg develop into a baby?

- (1) A
- (2) B
- (3) C
- (4) D

2. Study the information in the table below.

	Parts where the cells are contained in	
	Human System	Plant System
Female reproductive cell	E	G
Male reproductive cell	F	H

Which of the following correctly identifies E, F, G and H?

	E	F	G	H
(1)	testes	ovaries	style	stigma
(2)	testes	ovaries	ovules	anther
(3)	ovaries	testes	ovules	anther
(4)	ovaries	testes	stigma	style

3. Jenny has a plant in her garden that produces brightly-coloured flowers. She removed the petals of one of the flowers. A section of this flower is shown below.

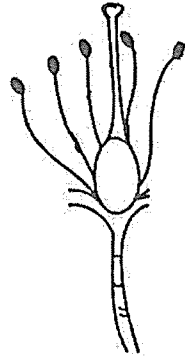

Flower without petals

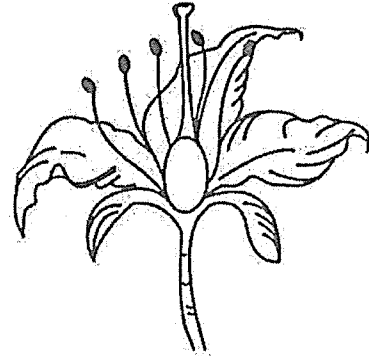

Flower with petals

She observed that the flower without petals took a longer time to be developed into a fruit as compared to the flower with petals.

Which one of the following statements about the flower without petals best explains Jenny's observation?

- (1) The anthers produced lesser pollen grains.
- (2) The stigma was unable to catch the pollen grains in the wind.
- (3) The pollinators were less attracted to the flower to carry out pollination.
- (4) The pollinators were less attracted to the flower to carry out germination.

Refer to the diagrams and information below to answer Questions 4 and 5.

Cayden removed the food carrying tubes from a tree as shown in the diagram below.

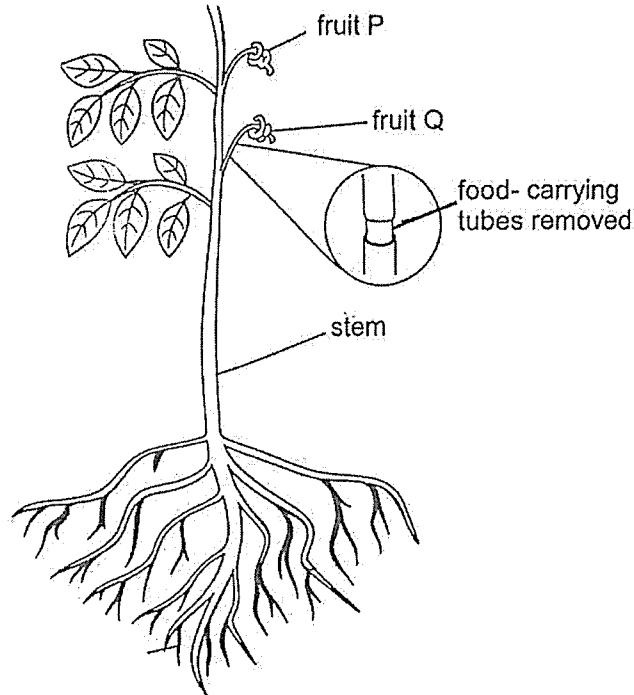

After two weeks, she noticed that only fruit P became bigger.

4. Which of the following explains why only fruit P became bigger?
- (1) Fruit P was able to make more food than fruit Q.
  - (2) Water taken in by the roots was transported to fruit P only.
  - (3) Food made by the leaves was transported to fruit P but not fruit Q.
  - (4) Water-carrying tubes transported more water to fruit Q than to fruit P.
5. Which of the following are possible observations of the whole plant after a few weeks?
- (1) The leaves withered.
  - (2) The tree continues to grow well.
  - (3) The roots does not get enough food and shrank.
  - (4) Fruit Q does not get enough water and dried up. ✗

6. Which of the following correctly shows the function of the nose and the lungs?

	Function of Nose	Function of Lungs
(1)	moistens the air	pumps air around the body
(2)	has tiny hairs to filter the air	allows for gaseous exchange
(3)	carbon dioxide is removed from the blood	moistens the air
(4)	oxygen is removed from the blood	allows for gaseous exchange

7. Which of the following correctly shows the comparison of oxygen and carbon dioxide in the air that we breathe?

- (1) There is a higher amount of oxygen in exhaled air than in inhaled air.
- (2) There is a lower amount of carbon dioxide in inhaled air than in exhaled air.
- (3) The amount of oxygen in inhaled and exhaled air remains the same.
- (4) The amount of carbon dioxide in inhaled and exhaled air remains the same.

8. Ahmad drew the diagram below to represent blood flow in some parts of the body.

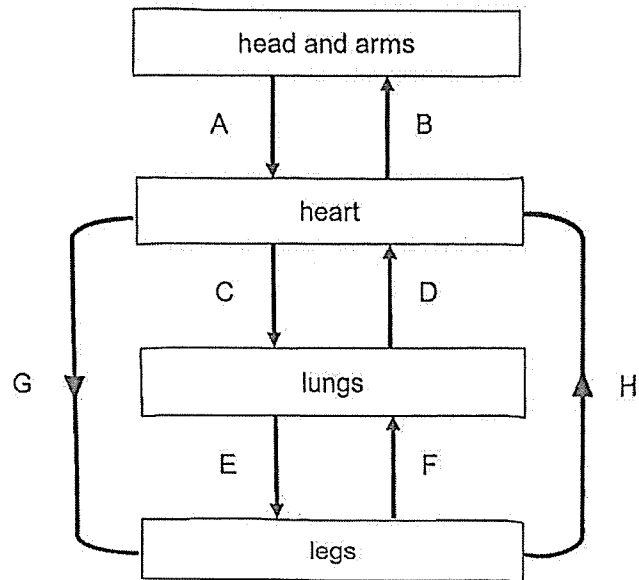

Which of the arrows are wrongly drawn?

- (1) A and C
  - (2) B and D
  - (3) E and F
  - (4) G and H
9. Which of the following is the correct function of the human circulatory system?
- (1) protects organs in the body
  - (2) absorbs water from undigested food
  - (3) takes in oxygen from the surrounding into the body
  - (4) transports waste materials away from different parts of the body for removal

10. The diagram below shows the processes taking place in organs M and P, which are parts of the human digestive system.

Process	M	P
Water is absorbed	Yes	No
Digestive juice is produced	No	No
Food is broken into smaller pieces	No	No

Which of the following correctly identifies organs M and P?

	M	P
(1)	large intestine	gullet
(2)	large intestine	mouth
(3)	small intestine	mouth
(4)	small intestine	gullet

11. Jenny set up two identical beakers, Q and R, with the same amount of digestive juice and the same mass of meat in each beaker as shown in the diagram below.

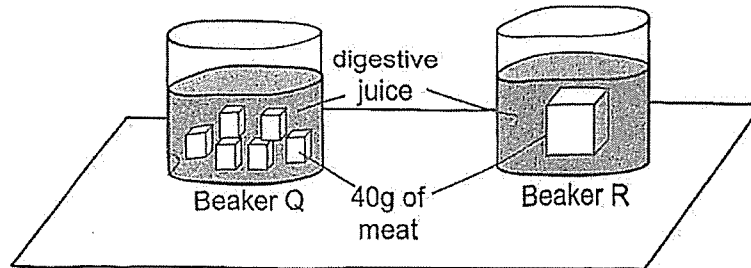

Four hours later, Jenny weighed the mass of the remaining meat in each beaker. While the mass of meat in both beakers decreased, she observed that the total mass of meat in beaker Q is less than the mass of meat in beaker R.

Based on her observations, she concluded her investigation by making the following statements:

- A No digestion took place in beaker R.
- B More digestion took place in beaker Q.
- C Smaller pieces of food help to speed up digestion.
- D The mass of food in each beaker at the start affected the rate of digestion.

Which of the statements are correct?

- (1) A and B only
  - (2) A and D only
  - (3) B and C only
  - (4) C and D only
12. Which group of living things has a four-stage life cycle?

- (1) butterfly, frog, mosquito
- (2) frog, grasshopper, cockroach
- (3) butterfly, mealworm beetle, mosquito
- (4) cockroach, grasshopper, mealworm beetle

13. The diagram below shows the life cycle of animal X.

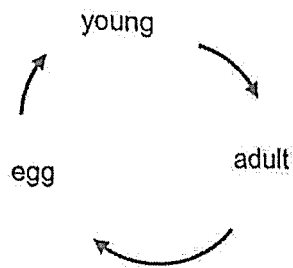

The graph below shows the number of weeks animal X remains in each stage of its life cycle.

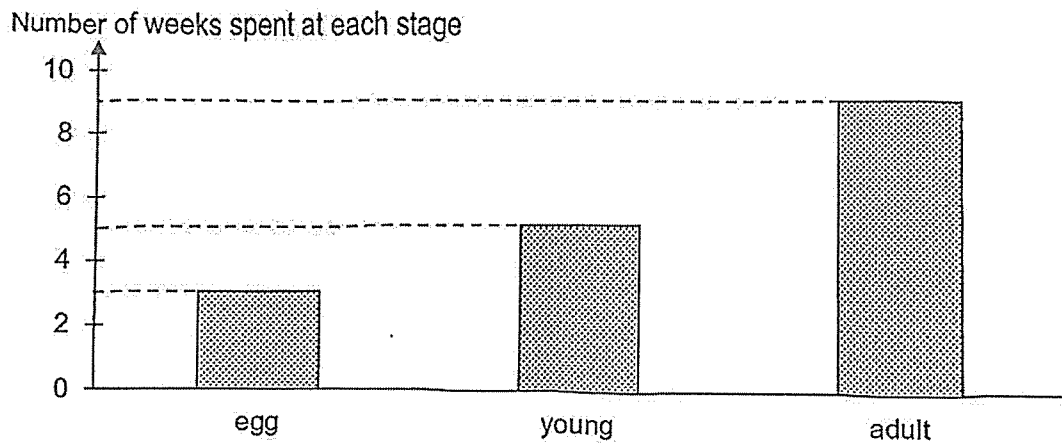

Based on the graph, which statement about the life cycle of animal X is correct?

- (1) Animal X is a mosquito.
- (2) The animal spends fewer weeks as a young than as an adult.
- (3) The animal takes 5 weeks to become an adult after the egg is laid.
- (4) After the young hatches from the egg, it takes 17 weeks to become an adult.

14. Which of the following correctly shows the life cycle of a plant?

(1)

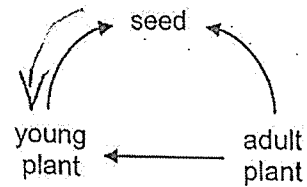

(2)

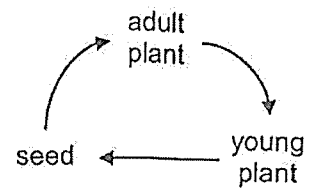

(3)

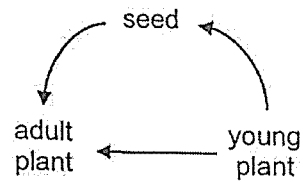

(4)

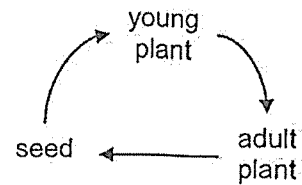

15. The table below shows the freezing and boiling point of three substances, X, Y and Z.

Substance	Freezing point (°C)	Boiling point (°C)
X	13	105
Y	22	48
Z	105	210

Based on the table above, which of the following statements is correct?

- (1) X is a solid at 27°C.
- (2) X and Y are liquids at 20°C.
- (3) Y and Z are solids at 130°C.
- (4) X and Y are gases at 120°C.

16. In the diagram below, A, B, C and D represent the different processes that result in a change in state of water.

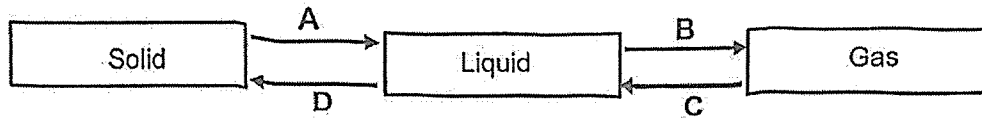

Which of the following processes correctly represent A, B, C and D?

	A	B	C	D
(1)	Melting	Boiling	Evaporation	Freezing
(2)	Freezing	Evaporation	Condensation	Melting
(3)	Melting	Boiling	Condensation	Freezing
(4)	Freezing <del>X</del>	Evaporation	Boiling	Melting

17. Ali poured an equal amount of water at different temperatures into 2 identical cups, A and B. He covered the cups with identical lids and left them in a room at 29°C. The diagrams below show what Ali observed after 10 minutes.

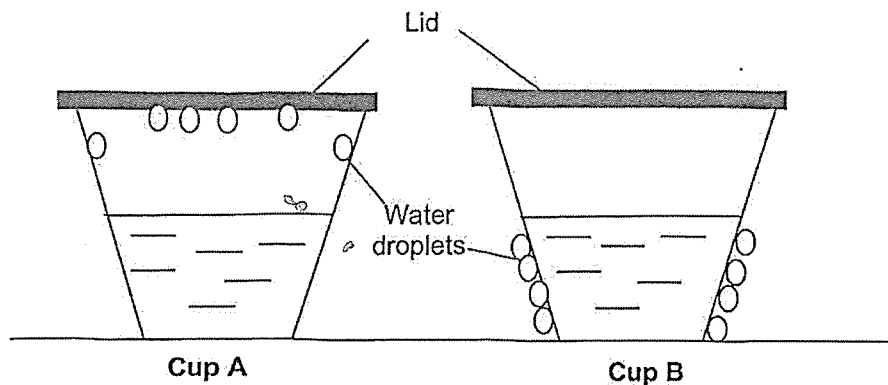

Which of the following shows the most likely temperature of water in each cup?

	Temperature of water in cup A (°C)	Temperature of water in cup B (°C)
(1)	10	80
(2)	10	10
(3)	80	10
(4)	80	80

18. Study the diagram below.

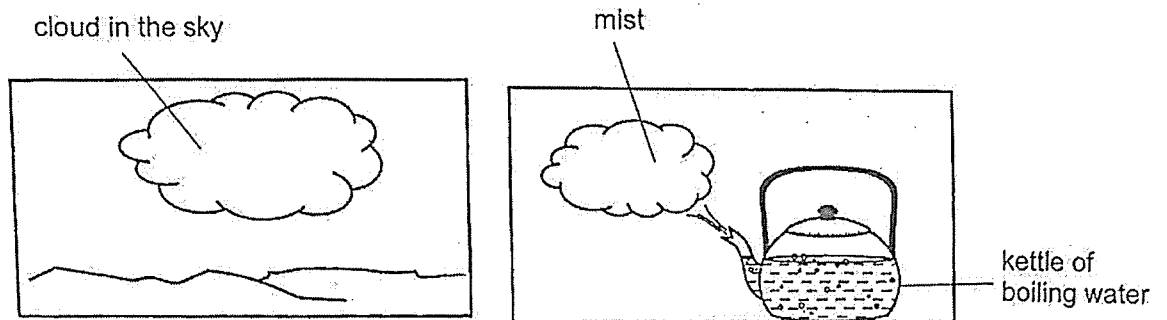

In what ways are the cloud in the sky and the mist formed around the spout of the kettle of boiling water similar?

- A Both are in liquid state.
- B Both are of the same temperature.
- C Both are formed by water gaining heat from the surrounding air.
- D Both are formed by water vapour losing heat to the surrounding air.

- (1) A and B only
- (2) A and D only
- (3) B and C only
- (4) A, C and D only

19. A large amount of fertilizer from a vegetable farm and animal waste from an animal farm flows into a nearby river at point X. A factory nearby would also dump their toxic waste into the nearby river. The arrow shows the direction in which the river flows. It was observed that the presence of fertilizer and animal waste turned the water cloudy.

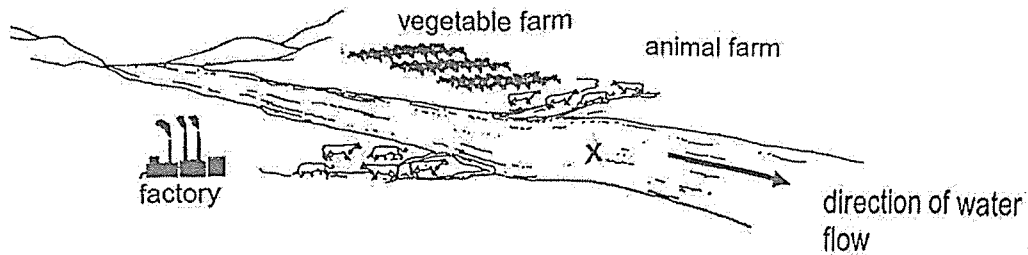

Which of the following graphs best represents the effect of fertilizer, animal waste and toxic waste on the amount of fishes in the river?

(1)

Amount of fishes

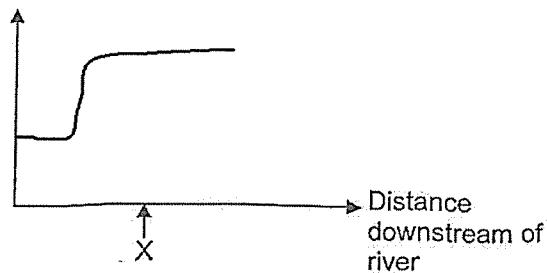

(2)

Amount of fishes

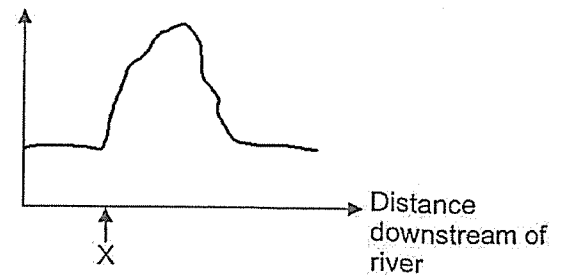

(3)

Amount of fishes

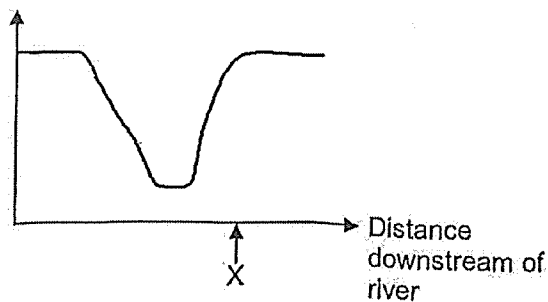

(4)

Amount of fishes

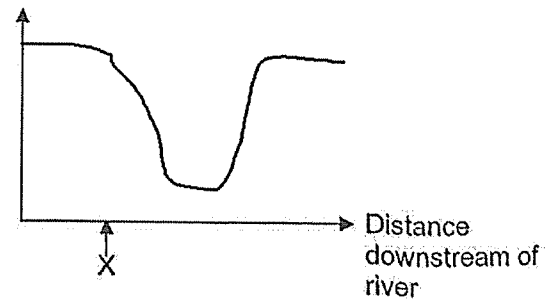

20. Which of the following activities can cause water pollution?

- A Using rainwater to wash the toilet.
- B Watering plants with water from washing rice.
- C Littering and dumping of waste into canals and rivers.
- D Spraying insecticide over the water in drains and ponds.

- (1) A and C only
- (2) C and D only
- (3) A, B and D only
- (4) B, C and D only

21. Lucian set up four circuits using identical batteries and bulbs as shown. All the circuit components are in working condition.

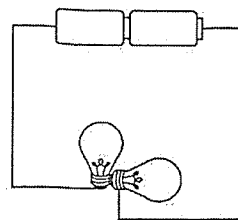

Circuit A

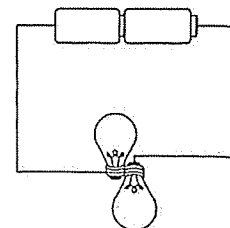

Circuit B

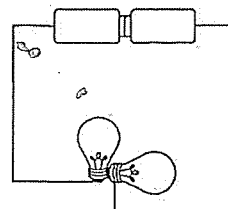

Circuit C

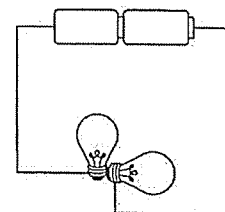

Circuit D

In which circuit would both bulbs light up?

- (1) Circuit A
- (2) Circuit B
- (3) Circuit C
- (4) Circuit D

22. Connie set up the electric circuit as shown below. All the electrical components are working. She observed that only bulb U lit up.

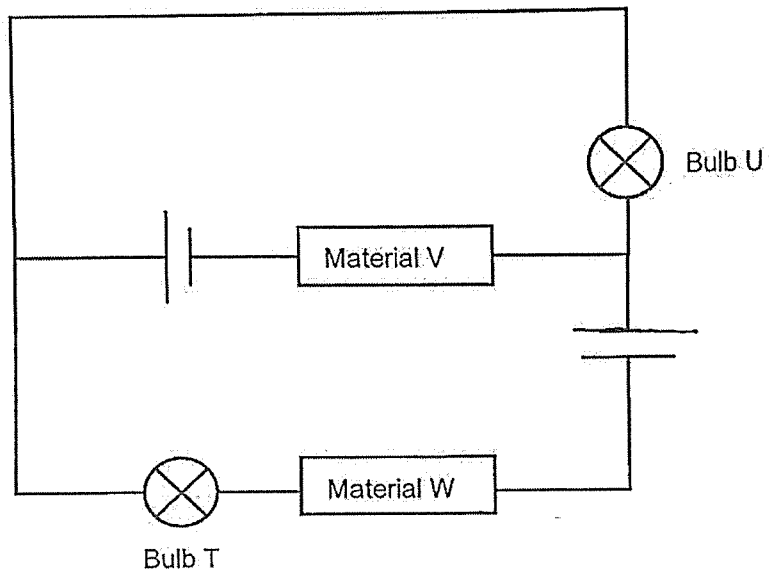

Which of the following is correct?

	Material V	Material W
(1)	Copper	Iron
(2)	Copper	Cardboard
(3)	Cardboard	Copper
(4)	Cardboard	Iron

Refer to the diagram below to answer Questions 23 and 24.

The diagram below shows a wire loop game which requires players to guide a loop along a wire. When the loop touches the metal maze, the bulb will light up.

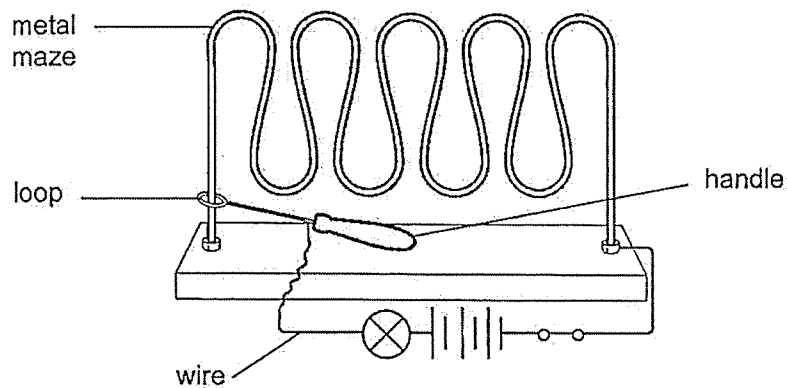

23. Which statement(s) is/are correct?

- A When the loop touches the metal maze, a closed circuit is formed.
- B The wire, loop and handle are made of electrical conductors.

- (1) A only
- (2) B only
- (3) Both A and B
- (4) Neither A nor B

24. Which statement(s) shows unsafe ways to play the wire loop game?

- P Use wires that are not insulated.
- Q Hold only the handle to play the game.
- R Touch the metal maze with wet hands.

- (1) Q only
- (2) P and R only
- (3) Q and R only
- (4) P, Q and R

25. Which of the following practices will help to conserve electricity?

- (1) Overload a socket with many plugs.
- (2) Use an air-conditioner instead of a fan.
- (3) Switch off the lights when leaving a room.
- (4) Choose electrical appliances with less green ticks.

26. Study the flowchart below.

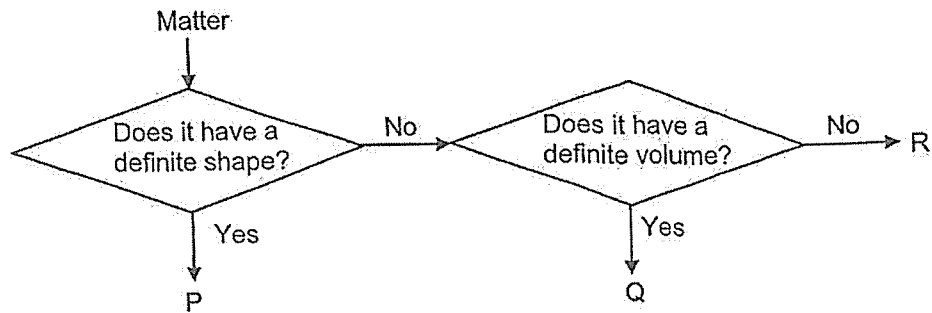

Which of the following best represents Q?

- (1) eraser
- (2) oxygen
- (3) football
- (4) orange juice

27. Jaya pumped more air into a basketball. The diagram below shows her observations of how the size and shape of the basketball did not change.

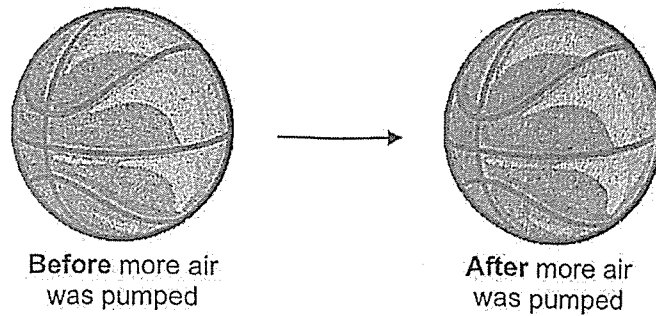

Which of the following best explains her observations?

- (1) Air has mass.
  - (2) Air takes up space.
  - (3) Air can be compressed.
  - (4) Air has a definite shape.
28. The device below measures the oxygen levels and pulse rate. In this device, light from the light source reflects off a person's finger into a light sensor. The light ray is shown in the diagram below.

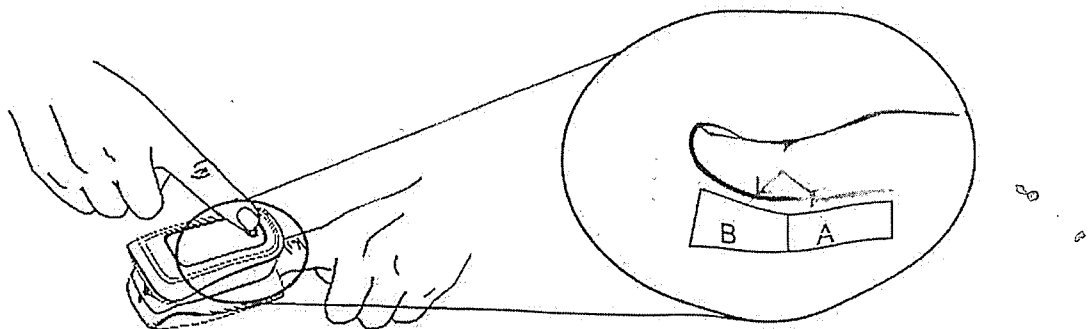

Based on the diagram, which statement is **not** correct?

- (1) Light can be reflected.
- (2) Light travels in straight lines.
- (3) A is the light source and B is the light sensor.
- (4) B is the light source and A is the light sensor.

29. Nora stood under a lamp as shown below.

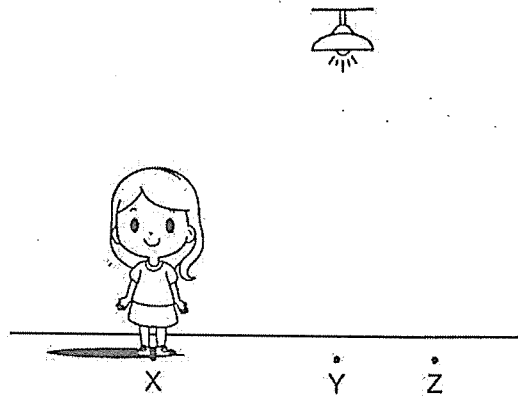

She walked in a straight line from position X to position Y, and then to position Z.  
Which graph shows how the length of her shadow changed during this time?

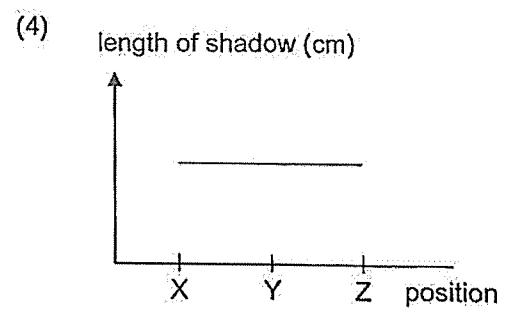
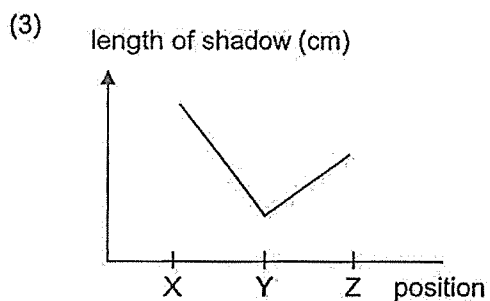
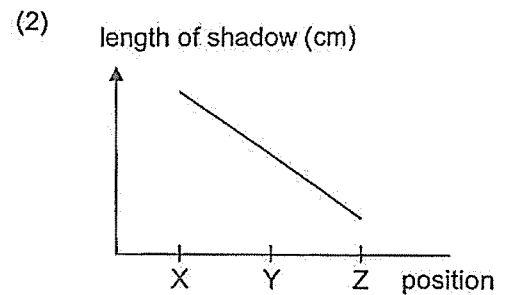
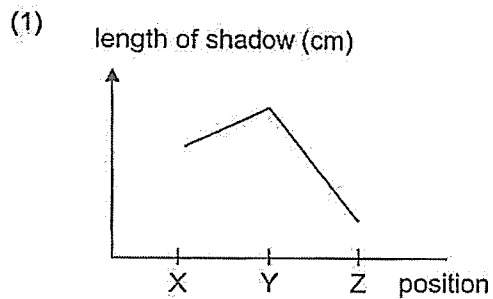

30. The diagram below shows Kumar holding a metal plate in one hand and a wooden plate in the other.

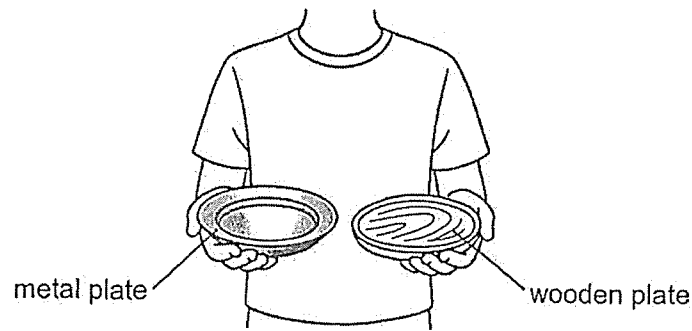

He noticed that the metal plate felt cold but not the wooden plate. If both plates were in the same room for the same duration, why did the metal plate feel cold while the wooden plate did not?

- (1) The temperature of the metal plate is higher than Kumar's hand.
- (2) The metal plate lost more heat to Kumar's hand than the wooden plate did.
- (3) The metal plate gained more heat from Kumar's hand than the wooden plate did.
- (4) The wooden plate gained more heat from Kumar's hand than the metal plate did.

8 . 8

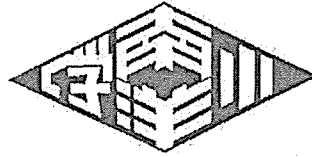

NANYANG PRIMARY SCHOOL  
END-OF-YEAR EXAMINATION  
2025

PRIMARY 5  
SCIENCE  
(BOOKLET B)

Total Time for Booklets A and B: 1 hour 45 minutes

**INSTRUCTIONS TO CANDIDATES**

1. Write your name and index number in the space provided.
2. Do not turn over this page until you are told to do so.
3. Follow all instructions carefully.
4. Answer all questions.
5. Write your answers in this booklet.

Name: \_\_\_\_\_ (       )

Class: Primary 5 (       )

Parent's Signature: \_\_\_\_\_

Please sign and return the examination paper the next day. **Any queries should be raised at the time when the paper is returned.**

Booklet A	/ 60
Booklet B	/ 40
Total	/ 100

This booklet consists of 13 printed pages and 0 blank page(s).

Section B: Open-Ended Questions [40 marks]

31. The diagram shows the fruits and seeds of different plants.

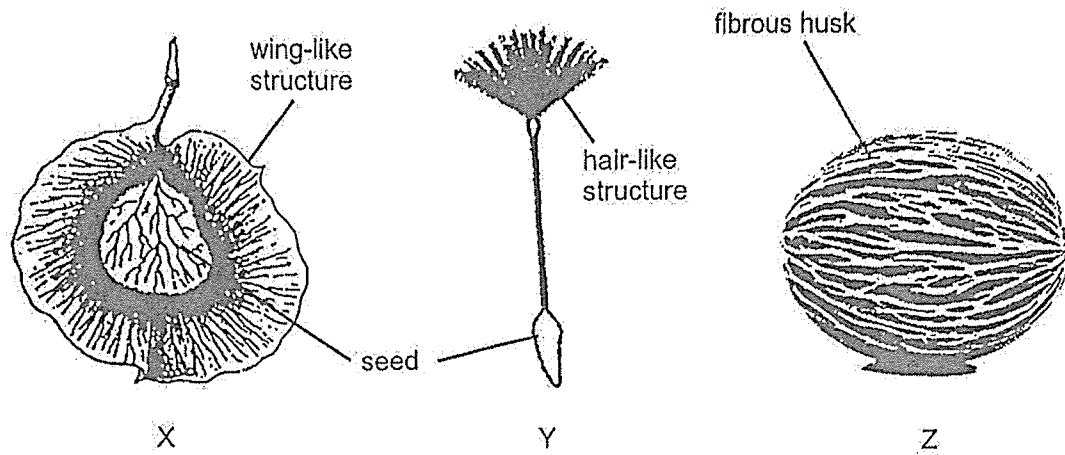

(a) Based only on the observable characteristics of the fruits and seeds above, which one is most likely dispersed by water? Explain your answer. [2]

---

---

---

(b) What is the disadvantage for the dispersal method of fruit Y? [1]

---

---

Study the diagram below.

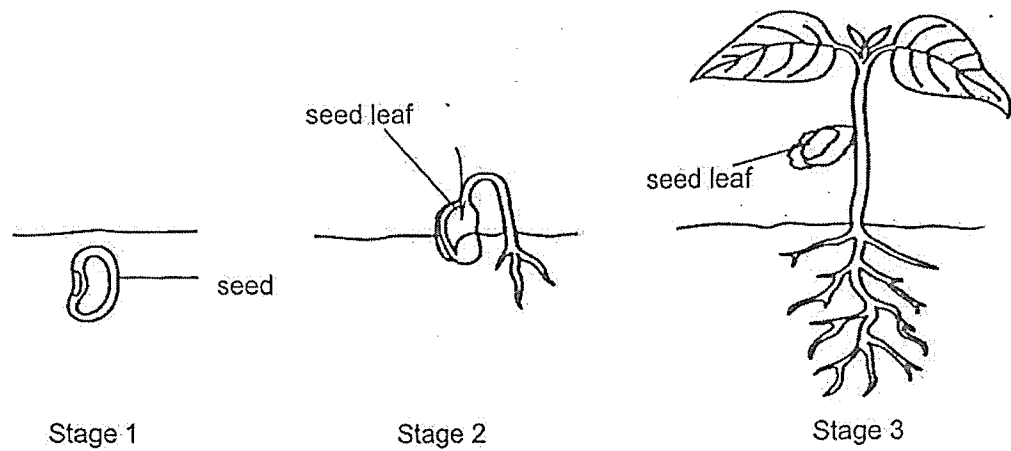

- (c) State all the conditions needed for the seed to germinate from stage 1 to stage 2. [1]

---

- (d) The seed leaf in stage 3 is observed to be much smaller than in stage 2. Give a reason for the observation. [1]

---

---

32. Herman went for a jog in the park. He measured his heart rate throughout the jog. The graph below shows his heart rate over a period of time.

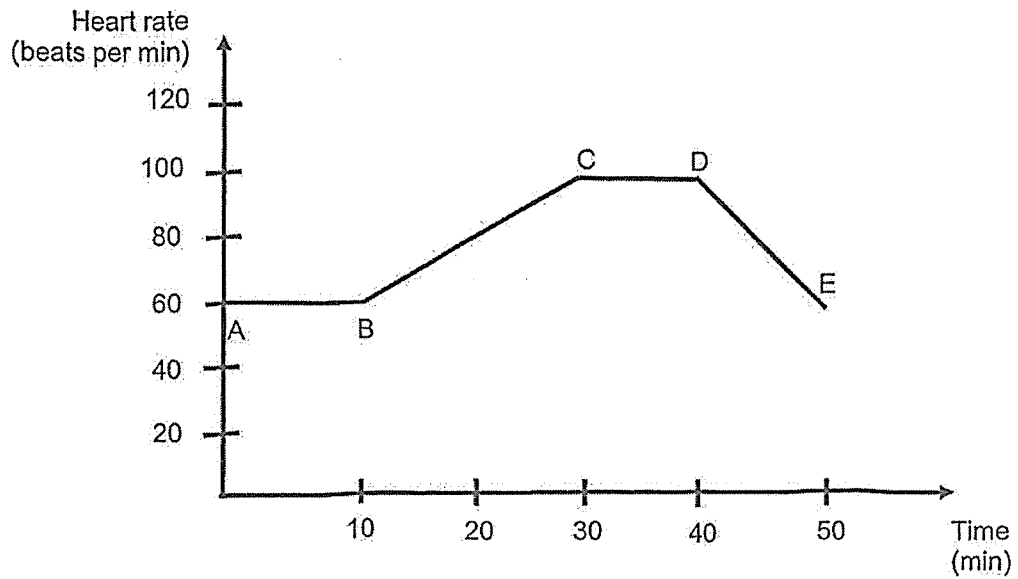

- (a) What is Herman's heart rate when he is at rest? [1]  
 \_\_\_\_\_ beats per min.
- (b) Identify the point at which Herman [1]  
 (i) started running:  
 Point \_\_\_\_\_  
 (ii) stopped running:  
 Point \_\_\_\_\_
- (c) Describe and explain the change in Herman's heart rate when he stopped running. [2]

---



---



---



---

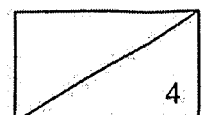

33. The table below shows the amount of undigested food in the different parts of the digestive system.

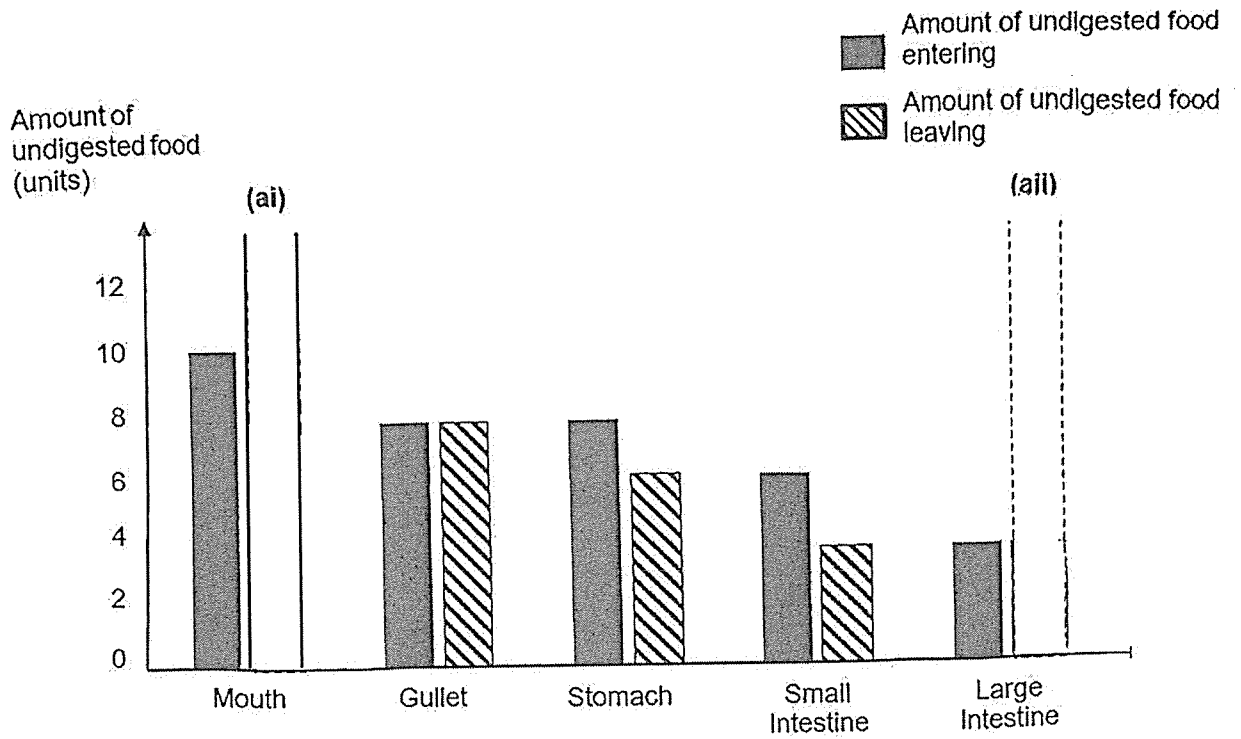

(a) Using the space within the dotted lines of the diagram above, draw two bars to complete the graph which best represent the following: [1]

- (i) Amount of undigested food leaving the mouth.
- (ii) Amount of undigested food leaving the large intestine.

(b) State two functions of the small intestine. [2]

- (i) \_\_\_\_\_
- (ii) \_\_\_\_\_

(c) Why does the amount of undigested food entering and leaving the gullet remain the same? [1]

\_\_\_\_\_

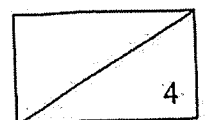

34. Animal X lives on land and only its young are found on the leaves of plants. The adult of animal X feeds on other insects to survive. When animal X is found on the plants in a farm, farmers will have more damaged plants.

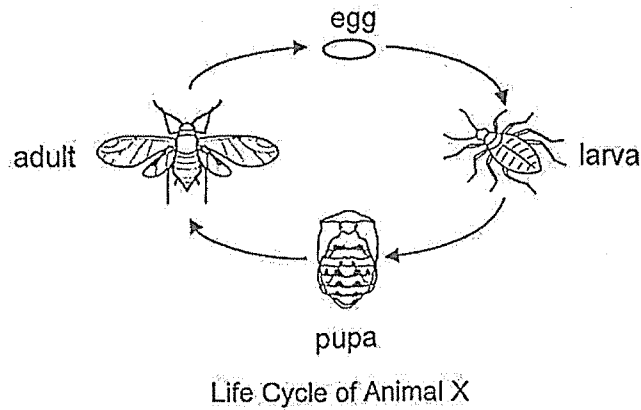

In 2025, farmers sprayed substance Q on the leaves of plants to reduce the amount of damaged plants. When substance Q is eaten, only the young of animal X is affected.

- (a) State the stage of the life cycle affected by substance Q. Give a reason for your answer. [1]

---



---

- (b) Complete the line graph below to show how the number of animal X will change over time after the farmers sprayed substance Q on the leaves of plants in 2025. [1]

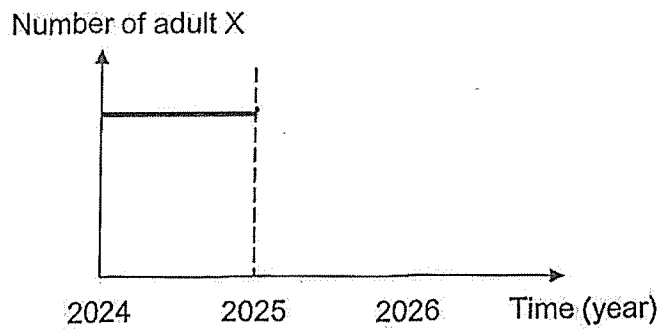

- (c) State one similarity and one difference between the life cycle of animal X and the life cycle of a grasshopper. [2]

(i) Similarity:

---



---

(ii) Difference:

---



---

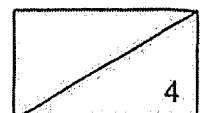

35. Alima wanted to find out if the amount of water affects the height of a plant after two weeks. She prepared four pots of seeds, as shown in the table below.

	Pot D	Pot E	Pot F	Pot G
Mass of soil (g)	200	500	200	500
Type of seeds	Seed X	Seed Y	Seed Y	Seed Y
Amount of water (ml)	50	50	100	100

- (a) Which two pots of seeds should Alima use for the experiment to be a fair test? [1]

- (b) Which of the following apparatus should Alima use to accurately measure the height of the plant? Put a tick (✓) in the correct box. [1]

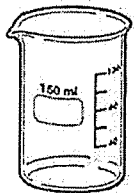
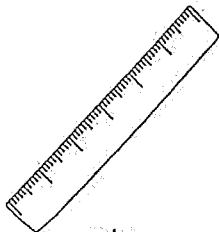
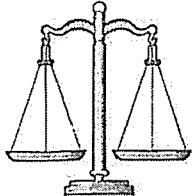
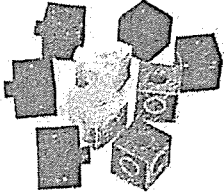
 beaker	 ruler	 weighing balance	 1cm unit cubes
<input type="checkbox"/>	<input type="checkbox"/>	<input type="checkbox"/>	<input type="checkbox"/>

Alima carried out her experiment using the appropriate pots of plants. She watered one pot with 50ml of water daily and the other pot with 100 ml of water daily.

Her results are shown below.

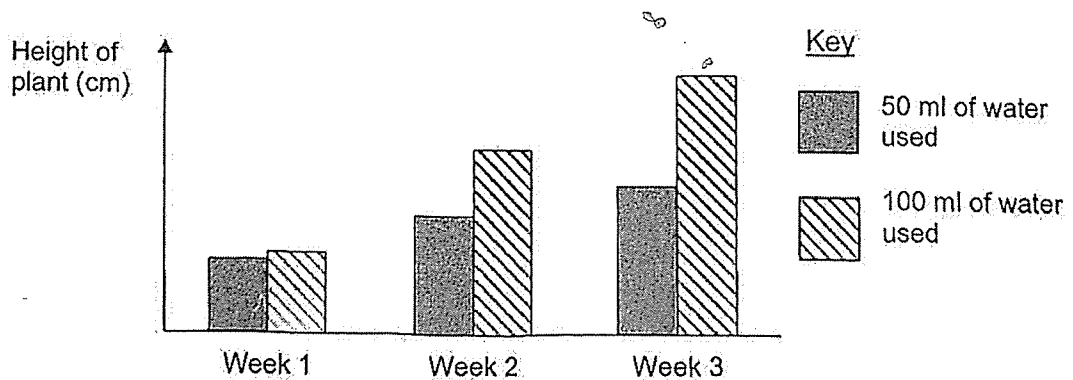

- (c) State what Alima can conclude from her results. [1]

36. Shanti has two containers, X and Y, as shown below.

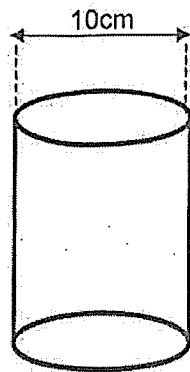

Container X

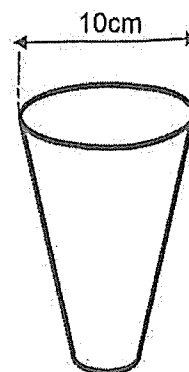

Container Y

She filled the containers with 500ml of water each. She left the containers on a table in the same room for two days and then measured the amount of water left in the containers after two days.

(a) Why did Shanti use the same amount of water at the start of the experiment? [1]

---

---

(b) Which container would have more water left in it after two days? Explain your answer. [2]

---

---

---

(c) State another way in which the rate of evaporation of the water can be increased [1]

---

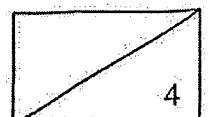

37. John put together the set-up below.

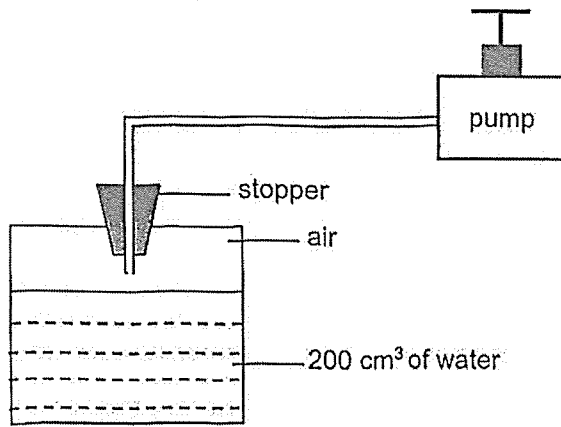

The container has a capacity of 300 cm<sup>3</sup>.

(a) 1) What is the volume of air in the container? [1]

\_\_\_\_\_ cm<sup>3</sup>

Using the pump, 50 cm<sup>3</sup> of water was added into the container.

(a) What is the final volume of air in the container? Explain your answer. [2]

---



---



---

To release the water in the container, a small hole was made at the bottom of the container and water started dripping out slowly.

(b) Without changing the hole or adding another hole, what can John do to increase the rate of water dripping out of the container? [1]

---



---

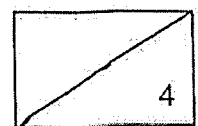

38. Liam conducted an experiment using two beakers, F and G. The table below shows the conditions in both beakers.

Beaker	Temperature of water at the start (°C)	Volume of water (ml)
F	80	500
G	80	180

Liam wanted to cook an egg by leaving it in the beaker of hot water.

- (a) In which beaker would the egg cook faster? Give a reason for your answer. [2]

---



---

Liam conducted another experiment using 2 beakers made of identical materials, J and K. The beakers are completely filled with water. He placed a lid made of different materials on beakers J and K. After 3 minutes, he measured the temperature of water in both beakers and recorded it in the table below.

Beaker	Temperature of water at the start (°C)	Volume of water (ml)	Temperature of water at the end (°C)
J	80	200	45
K	80	200	20

- (b) Suggest a possible material for the lid covering beaker K. Explain your answer. [2]

---



---



---

39. Mei Mei made an electromagnet as shown in the diagram below.

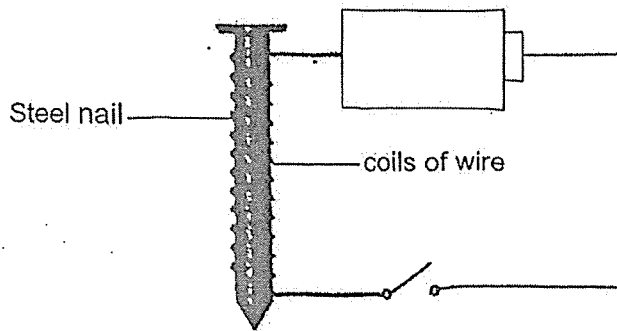

- (a) State one way, Mei Mei can increase the strength of the electromagnet without using other materials. [1]

---

The diagram below shows a car park barrier which uses an electromagnet to operate. When there is no car in front of the barrier, the switch is open and the barrier is in the position shown in the diagram below.

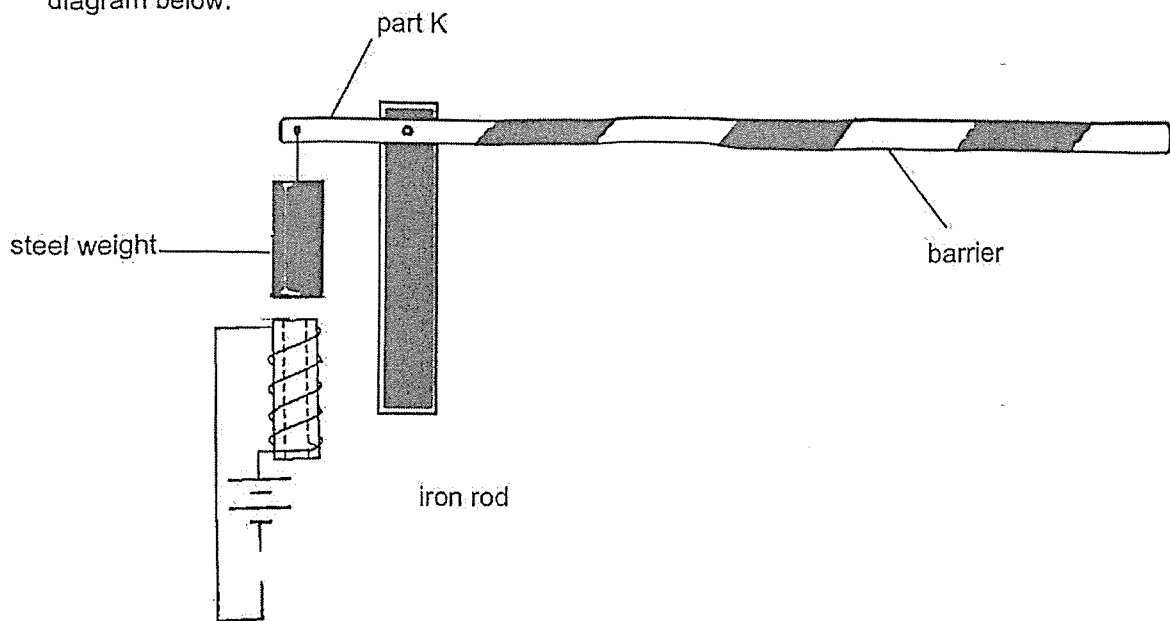

- (b) Based on the diagram above, explain clearly how the electromagnet helps to lift the barrier when the car approaches. [2]

---



---



---

40. Harold bought a toy microwave as shown in diagram 1. The electric circuit of the microwave contained a motor to spin the plate, bulb P and bulb Q as shown in diagram 2. Bulbs P and Q are identical bulbs. All the circuit components are in working condition.

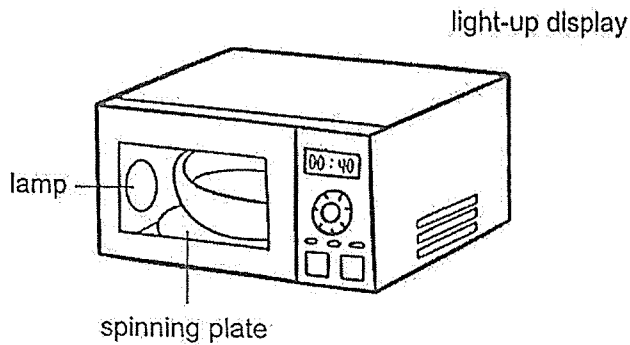

Diagram 1

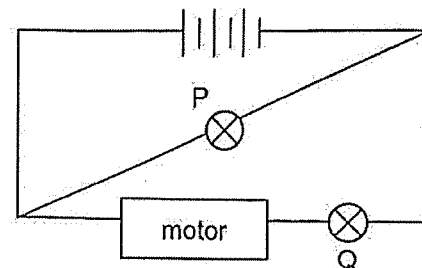

Diagram 2

When the motor for the spinning plate stopped working, the lamp no longer lit up but the light-up display could still work.

- (a) Identify the bulb used for the lamp and light-up display respectively. [1]

Lamp: Bulb \_\_\_\_\_

Light-up display: Bulb \_\_\_\_\_

- (b) Give a reason why the bulb for the light-up display could still work when the motor stopped working. [1]

---



---

Harold replaced the motor with bulb R. Bulb R is identical to bulbs P and Q, and in working condition.

- (c) Describe and compare the brightness of bulbs P, Q and R. [1]

---



---

(Go on to the next page)

(Continued from previous page)

Harold wants to rearrange the circuit such that all the bulbs have the same brightness.

(d) Draw the circuit diagram of the rearranged circuit by including the following:

[2]

- 3 battery
- 3 bulbs
- wires

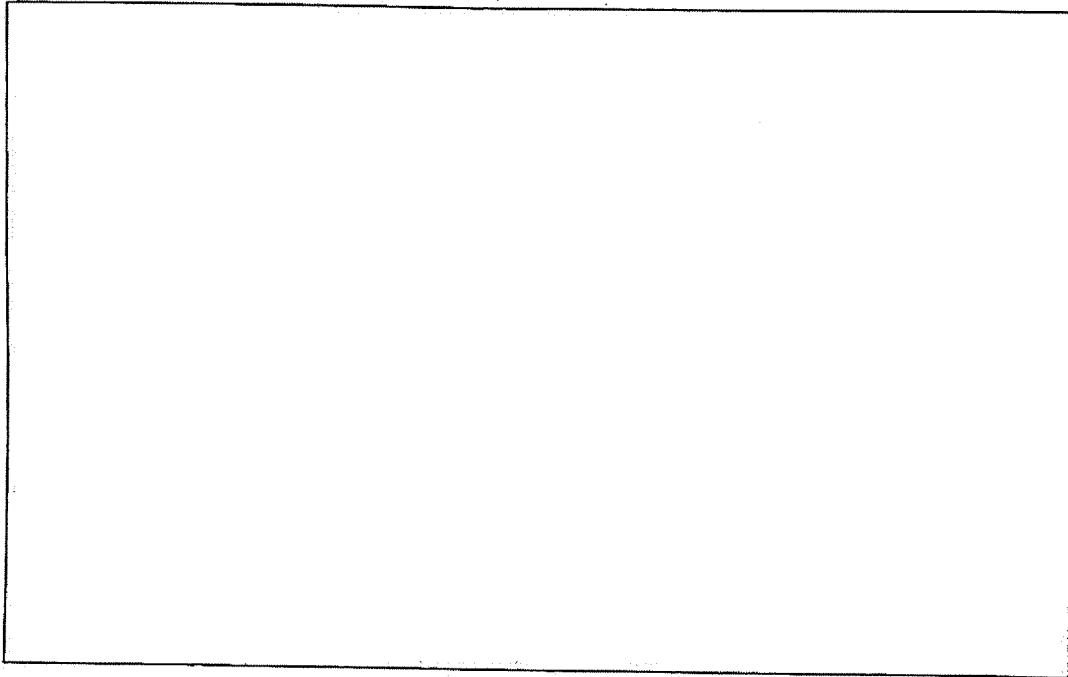

8

**SCHOOL : NANYANG PRIMARY SCHOOL**  
**LEVEL : PRIMARY 5**  
**SUBJECT : SCIENCE**  
**TERM : 2025 END OF YEAR EXAMINATION**

Q1	Q2	Q3	Q4	Q5	Q6	Q7	Q8	Q9	Q10
2	3	3	3	2	2	2	3	4	1
Q11	Q12	Q13	Q14	Q15	Q16	Q17	Q18	Q19	Q20
3	3	2	4	4	3	3	2	4	2
Q21	Q22	Q23	Q24	Q25	Q26	Q27	Q28	Q29	Q30
1	2	1	2	3	4	3	4	3	3

31(a)	Z. It has fibrous husk that traps air and allows it to float on water.
31(b)	Fruit Y is dependent on the availability of wind for dispersal.
31(c)	Warmth / suitable temperature, oxygen / air and water.
31(d)	Food in the seed leaf had been used up.
32(a)	60 beats per minute (bpm).
32(b)(i)	Point B
32(b)(ii)	Point D
32(c)	His heart rate decreased. His heart pumped blood slower / pumped less blood as less oxygen and digested food is needed.
33(a)	<p>Amount of undigested food (units)</p> <p>Legend:          ■ Amount of undigested food entering          ▨ Amount of undigested food leaving</p> <p>ai) Lower than black bar for mouth but same height as gullet.          aii) Same as black bar for large intestine.</p>

33(b)(i)	Absorb digested food into the bloodstream.
33(b)(ii)	Breaks down food into simpler substance.
33(c)	No digestion took place.
34(a)	Larva stage. The larva will feed / eat substance Q on the leaves.
34(b)	<p>Number of adult X</p> <p>2024      2025      2026      Time (year)</p>
34(c)(i)	Similarity: The life cycle of the grasshopper and organism X are entirely on land.
34(c)(ii)	Difference: Grasshopper has a 3-staged life cycle while organism X has a 4-staged life cycle. / Grasshopper has young that resemble the adult while organism X's young does not resemble the adult.
35(a)	Pot E and Pot G
35(b)	Ruler
35(c)	More water causes plants to grow faster / taller.
36(a)	To ensure that the result of her experiment is affected only by the change in the exposed surface area of the water and not any other factors.
36(b)	Container Y. The exposed surface area of water decreased over time so the rate of evaporation decreased.
36(c)	Place a fan near the containers / Place the containers in a location of higher temperature.
37(a)(i)	$100 \text{ cm}^3$
37(a)(ii)	$50 \text{ cm}^3$ . The added water took up the space previously occupied by the air. Air can be compressed.
37(b)	Remove the stopper / Pump more air into the container.
38(a)	F. F has a greater volume of water so it has more heat to cook the egg.
38(b)	Metal / steel / iron. The temperature of water in K decrease faster. Metal is a good / better conductor of heat so the lid conduct / lose heat faster to the surrounding.

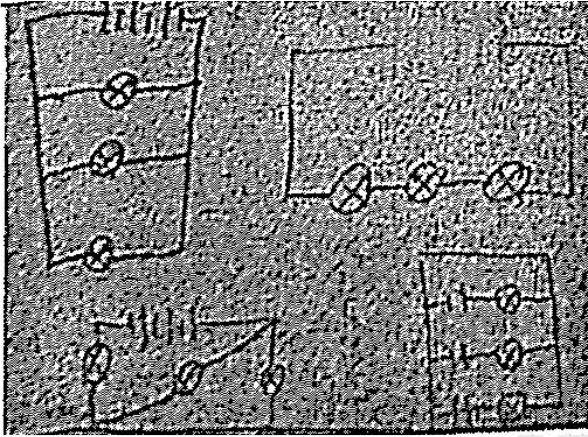
39(a)	Increase the number of coils of wire around the steel nail.
39(b)	When the switch is closed, a closed circuit is formed. Iron rod becomes magnetised and attracts the steel weight. This pulls part K down, lifting barrier.
40(a)	Lamp: Bulb Q. Light-up display: Bulb P.
40(b)	The bulb for light-up display is arranged in parallel to the motor and electricity could still pass through.
40(c)	Bulb P was brighter than bulb Q and R. Bulb Q and R have the same brightness.
40(d)	

[www.sgexam.com](http://www.sgexam.com)