

Red Swastika School
Primary 5 Science 2025
Class Test 1

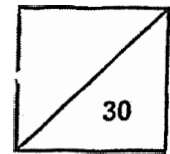

Name: _____ () Parent's Signature: _____

Class: Pr. 5 _____ Date: _____

Total time for sections A and B: 45 minutes

Section A: Multiple – Choice Questions (9 x 2 = 18 marks)

Choose the most suitable answer and shade its number in the OAS provided.

1. Study the classification chart below.

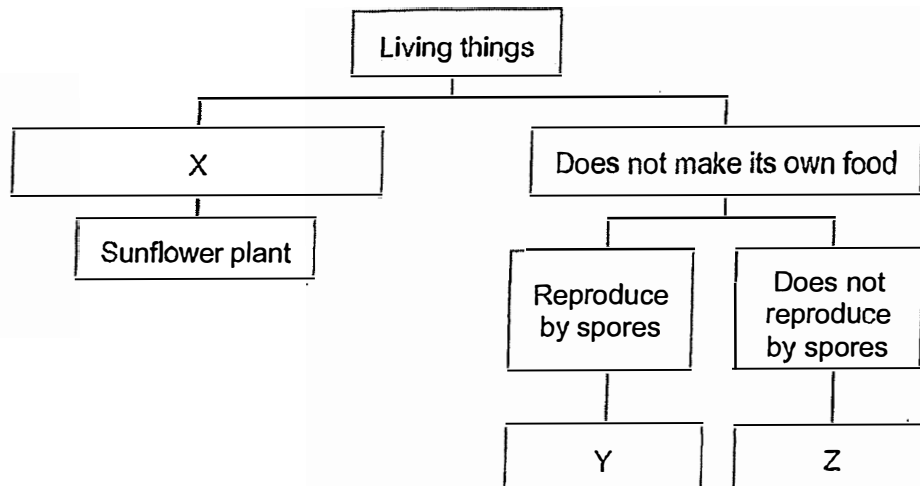

Which of the following best describes X, Y and Z?

	X	Y	Z
(1)	Makes its own food	mushroom	elephant
(2)	Makes its own food	bird's nest fern	mushroom
(3)	Does not produce flowers	mushroom	bird's nest fern
(4)	Does not produce flowers	bird's nest fern	elephant

2. The diagram below shows the human digestive system.

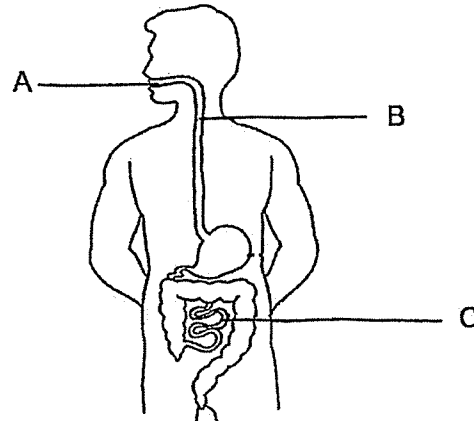

Which of the following best describes the changes in the amount of undigested food as it leaves parts A, B and C?

	A	B	C
(1)	No change	Increases	Decreases
(2)	No change	No change	Increases
(3)	Decreases	Increases	Increases
(4)	Decreases	No change	Decreases

3. The diagrams below show parts of the human and plant reproductive system.

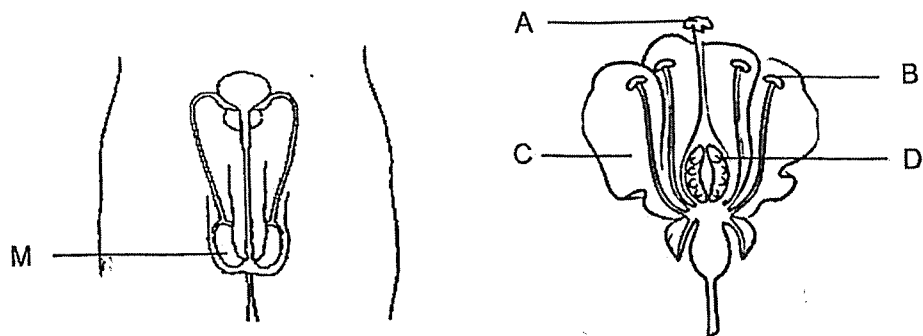

Which part of the plant reproductive system is similar in function to part M in the human reproductive system?

- (1) A
- (2) B
- (3) C
- (4) D

4. John found the following fruit below.

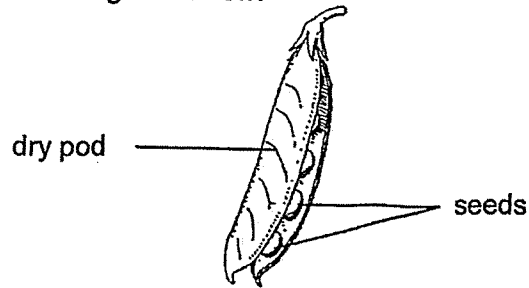

He made some statements about the fruit.

- A: The seeds are dispersed by wind.
- B: The seeds are dispersed by animals.
- C: The fruit of this plant develops from the ovary.
- D: The flower of this plant contains many ovules.

Which of the statements above are correct?

- (1) A and B
- (2) A and D
- (3) B and C
- (4) C and D

5. The diagram below shows the location of some adult plants, A, B and C, and their young.

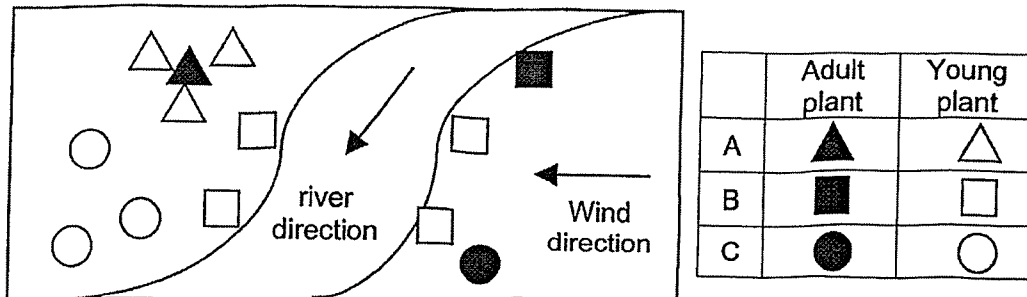

Based on the diagram above, how are the seeds of plants A, B and C dispersed?

	A	B	C
(1)	Water	Explosive action	Wind
(2)	Wind	Water	Explosive action
(3)	Explosive action	Water	Wind
(4)	Explosive action	Wind	Water

6. The table below shows the melting and boiling point of substance P.

Substance	Melting point (°C)	Boiling point (°C)
P	30	120

Which of the following shows the correct state of substance P at 15°C and 130°C?

	State at 15°C	State at 130°C
(1)	Solid	Gas
(2)	Solid	Liquid
(3)	Liquid	Solid
(4)	Liquid	Gas

7. Faris heated some ice cubes in a beaker. After a while, he stopped the heating and recorded the temperature change of the ice cubes in the graph below.

Temperature change of the ice cubes (°C)

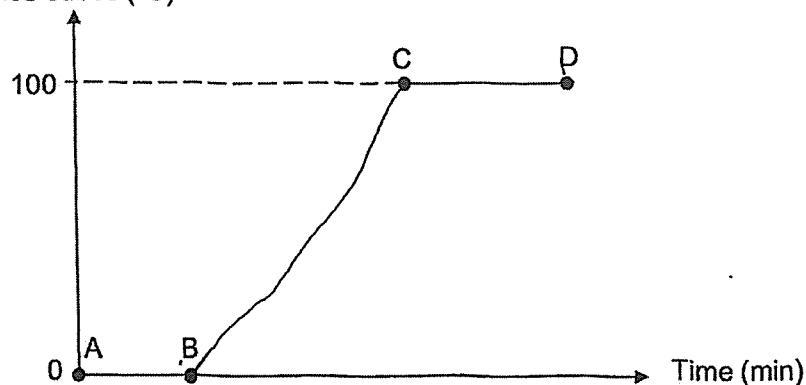

Which of the following statements is true?

- (1) There is no heat gain from A to B.
- (2) The ice starts melting from B to C.
- (3) No water evaporates from B to C.
- (4) There is a mixture of liquid and gas from C to D.

8. Dave has an inflatable water raft which can be used in a swimming pool as shown below.

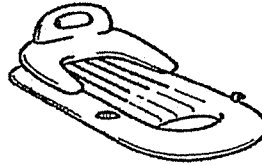

The table below shows the properties of four materials M, N, O and P.

Material	Is it waterproof?	Is it flexible?
M	No	Yes
N	No	No
O	Yes	Yes
P	Yes	No

Which of the material above is suitable for making the inflatable water raft?

- (1) M
 - (2) N
 - (3) O
 - (4) P
9. Sarah had a bar magnet and two rods, D and E, as shown below. She brought the north pole of the bar magnet near the ends of both rods and recorded her observations in a table.

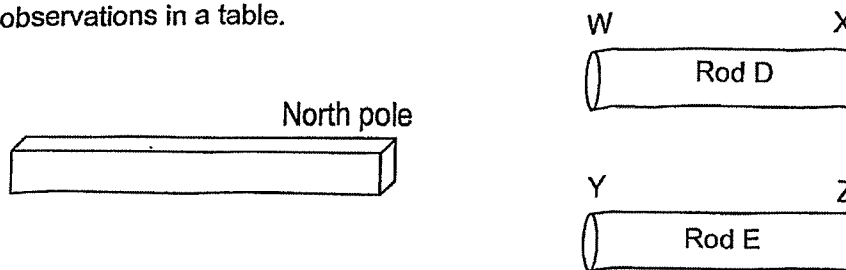

	Observations of end of rod			
	W	X	Y	Z
When North pole of the bar magnet was brought near	repel	attract	attract	attract

Based on the results in the table, which statement is correct about both rods?

- (1) Both D and E are magnets.
- (2) Both D and E are made of non-magnetic materials.
- (3) D is a magnetic material and E is a magnet.
- (4) D is a magnet and E is a magnetic material.

Section B: Open-Ended Questions (12 marks)
Answer all the questions in the space provided.

10. Observe flower A in the diagram below.

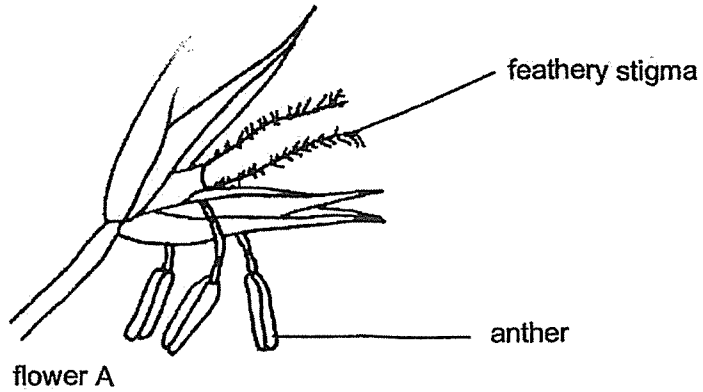

(a) What is the method of pollination for flower A? Explain how the characteristic of the flower part helps flower A to pollinate better. (2m)

The maps below show the location of two plants, B and C, on an island, three years apart. Plant B is observed to grow more healthily than plant C.

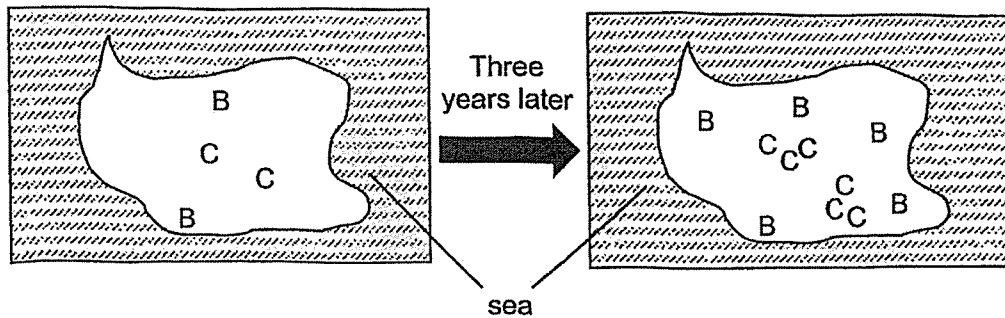

(b) Based on the maps above, explain why plant B was able to grow better than plant C. (2m)

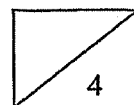

11. The diagram below shows two rooms in Andy's house, which are separated by a clear glass door. Andy was in room A, with the air conditioner turned on at 18°C. The temperature in room B was at 32°C.

After a while, Andy noticed tiny water droplets on the clear glass door as shown below.

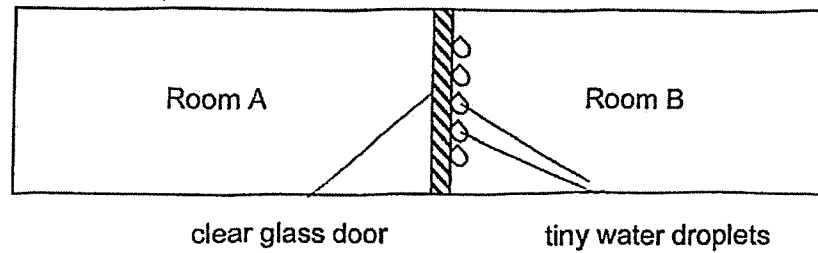

- (a) State the process that led to the formation of tiny water droplets. (1m)

- (b) Explain how the water droplets were formed on the clear glass door. (2m)

To reduce the amount of water droplets on the clear glass door, Andy decided to increase the temperature of room A.

- (c) Explain why increasing the temperature of room A will lead to less water droplets forming on the clear glass door. (1m)

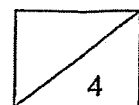

12. Natalie set up the experiment as shown below. When the switch to the circuit was closed, the iron rod moved towards the steel nail, forming an angle X.

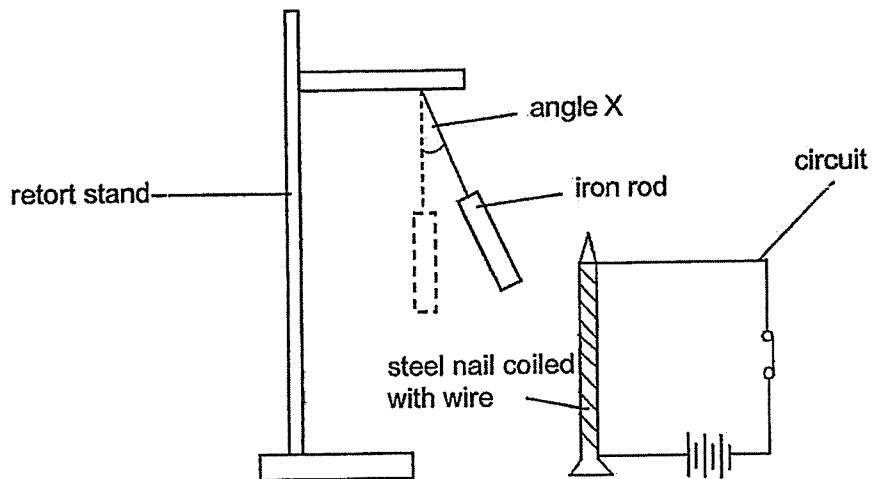

- (a) Which property of the iron rod allowed it to be attracted to the steel nail? (1m)

- (b) Without changing the position of the retort stand or the circuit, what can Natalie do to increase the angle X? (1m)

- (c) What will be the value of angle X if Natalie changes the iron rod to an aluminium rod? Explain your answer. (2m)

End of Paper 😊
Please check your answers.

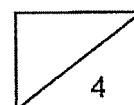

SCHOOL : RED SWASTIKA PRIMARY SCHOOL
LEVEL : PRIMARY 5
SUBJECT : SCIENCE
TERM : 2025 WEIGHTED ASSESSMENT 1

Q1	Q2	Q3	Q4	Q5	Q6	Q7	Q8	Q9	
1	4	2	4	3	1	4	3	4	

10(a)	<p>Flower A is pollinated by wind.</p> <p>It has a feathery stigma, which increases the surface area to trap pollen grains.</p> <p>OR</p> <p>It has anthers hanging out of the flowers so that more pollen grains can be carried away by the wind.</p>
10(b)	<p>Plant B's young plants grow further away from the parent plant. This leads to less competition for sunlight, water, mineral salts and space.</p>
11(a)	<p>Condensation</p>
11(b)	<p>The hot water vapour in room B came into contact with the cooler surface of the clear glass door. The water vapour lost heat and condensed into tiny water droplet.</p>
11(c)	<p>As the temperature of the room increases, the clear glass door gets warmer and there is less condensation.</p>
12(a)	<p>The iron nail is magnetic. / The iron is made of magnetic material.</p>
12(b)	<p>She can increase the number of coils wire around the steel nail</p> <p>OR</p> <p>She can increase the number of batteries in the circuit.</p>
12(c)	<p>Angle X will be 0°. Aluminium is a non-magnetic material so it will not be attracted by the steel nails.</p>

www.sgexam.com