



ROSYTH SCHOOL
2025 PRELIMINARY EXAMINATION
MATHEMATICS
PRIMARY 6
PAPER 1

Name: _____

Register No. _____

Class: Pr 6 -__

Date: 26 August 2025

Parent's Signature: _____

Total Time for Booklets A and B: 1 hour

BOOKLET A

Instructions to Pupils:

1. Do not turn over this page until you are told to do so.
2. Follow all instructions carefully.
3. Answer all questions.
4. Use a 2B pencil to shade your answers on the Optical Answer Sheet (OAS).
5. The use of calculators is **NOT** allowed.

Section	Maximum Mark	Marks Obtained
Paper 1 (Booklet A)	20	

* This booklet consists of **8** pages (including this cover page).

Questions 1 to 10 carry 1 mark each. Questions 11 to 15 carry 2 marks each.
For each question, four options are given. One of them is the correct answer.
Make your choice (1, 2, 3 or 4). Shade the oval (1, 2, 3 or 4) on the Optical Answer Sheet.

All diagrams in this paper are not drawn to scale unless stated otherwise.

(20 marks)

1. In the number 56.78, which digit is in the tens place?

- (1) 5
- (2) 6
- (3) 7
- (4) 8

2. Find the value of $6 - 2a + 5$ when $a = 2$.

- (1) 7
- (2) 13
- (3) 3
- (4) 15

3. There are 60 members in Art Club. 48 of the members are adults and the rest are children. What is the ratio of the number of children to the number of adults?

- (1) 1 : 4
- (2) 1 : 5
- (3) 4 : 1
- (4) 5 : 4

4. Ali paid \$135 for 9 swimming lessons.
At this rate, how much will he pay for 20 swimming lessons?

- (1) \$45
- (2) \$60.75
- (3) \$300
- (4) \$2700

5. Find the value of 30 kg 45 g + 9 kg 6 g.

- (1) 3951 g
- (2) 30 951 g
- (3) 39 051 g
- (4) 39 456 g

6. The figure below is not drawn to scale. Find the area of triangle ACD.

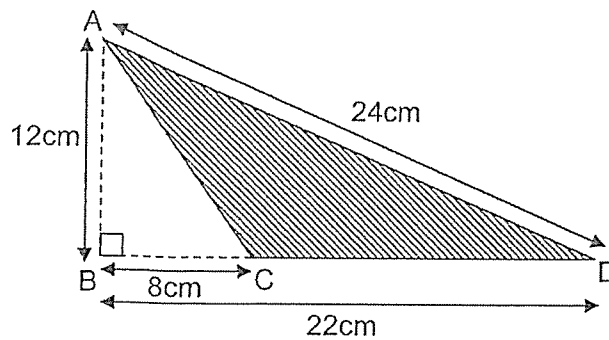

- (1) 48 cm²
- (2) 84 cm²
- (3) 132 cm²
- (4) 144 cm²

7. The figure shows a square-base pyramid.

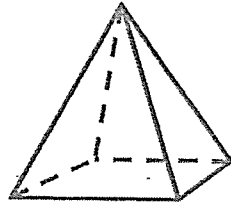

Which of the following is **not** a net of the pyramid?

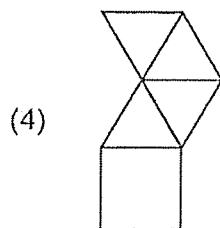
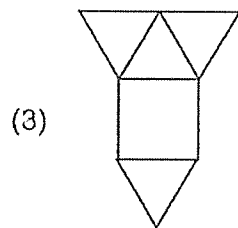
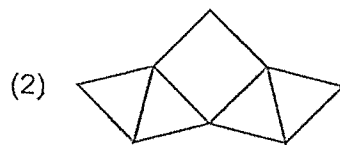
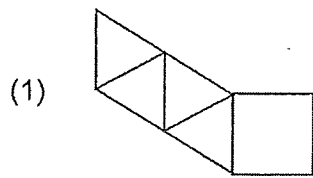

8. The sum of 4 numbers is 1008. One of the numbers is 198. What is the average of the other 3 numbers?

- (1) 54
- (2) 252
- (3) 270
- (4) 336

9. Each figure below is made up of 4 identical squares and 2 isosceles triangles. Which one has a line of symmetry?

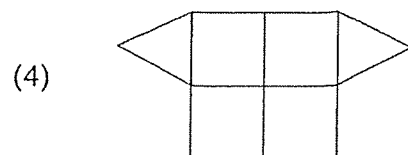
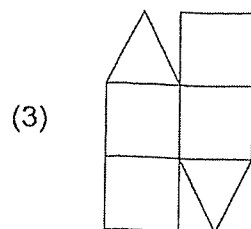
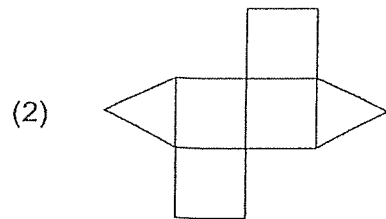
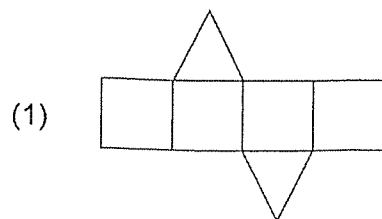

Use the information below to answer the Questions 10 and 11.

Kelly, Raju and Jon borrowed some books from the library to read. Figure 1 shows the number of books borrowed in May. Figure 2 shows the number of books borrowed in June.

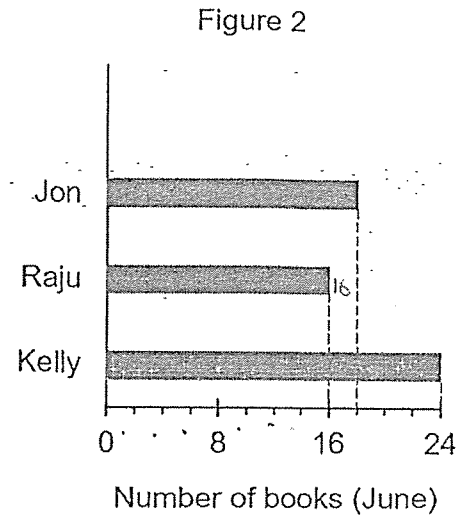
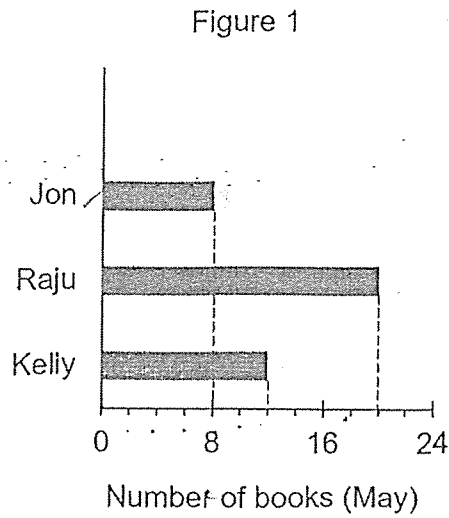

10. What was the total number of books borrowed by Jon in May and June?

- (1) 16
- (2) 18
- (3) 24
- (4) 26

11. How many more books were borrowed in June than in May?

- (1) 16
- (2) 18
- (3) 40
- (4) 58

12. In the number line, what is the value represented by A?

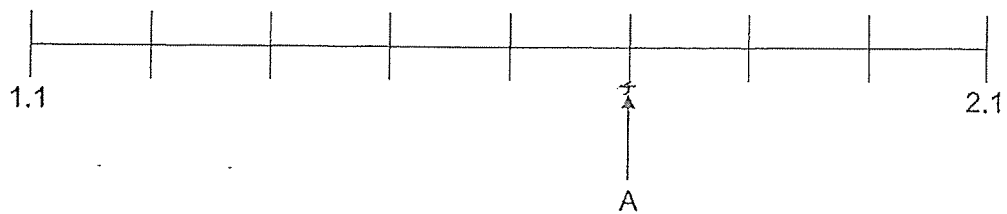

- (1) 1.225
 (2) 1.250
 (3) 1.725
 (4) 1.750
13. Mrs Tan had two pieces of ribbons of different lengths. She cut 60 cm from each ribbon. Then she had $\frac{3}{5}$ of the first ribbon left and $\frac{1}{4}$ of the second ribbon left. What was the total length of the two ribbons at first?
- (1) 150 cm
 (2) 230 cm
 (3) 300 cm
 (4) 460 cm
14. At a florist, there was an equal number of lilies, orchids and tulips. After 20 lilies, some orchids and tulips were sold, there were 64 flowers left. There were twice as many lilies left as orchids. The number of orchids left was 8 more than the number of tulips left. How many lilies were there at first?
- (1) 28
 (2) 36
 (3) 48
 (4) 56

(Go on to the next page)

15. The figure below is formed using 2 identical squares, 2 identical large equilateral triangles and 2 identical small equilateral triangles. The length of the square is 4 cm.

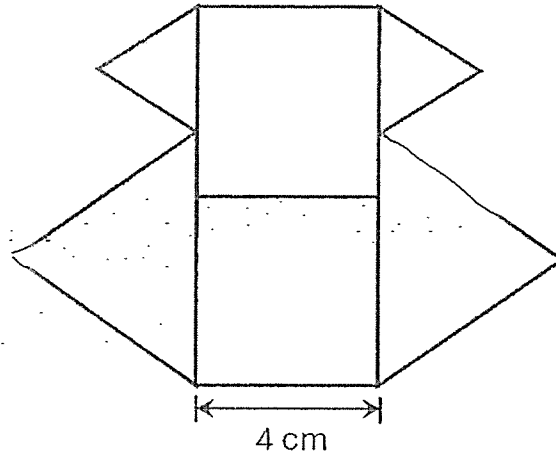

What is the perimeter of the figure?

- (1) 20 cm
- (2) 24 cm
- (3) 40 cm
- (4) 60 cm



ROSYTH SCHOOL
2025 PRELIMINARY EXAMINATION
MATHEMATICS
PRIMARY 6
PAPER 1

Name: _____

Register No. _____

Class: Pr 6 -

Date: 26 August 2025

Parent's Signature: _____

Total Time for Booklets A and B : 1 hour

BOOKLET B

Instructions to Pupils:

1. Do not turn over this page until you are told to do so.
2. Follow all instructions carefully.
3. Answer all questions.
4. Use a dark blue or black ballpoint pen to write your answers in the space provided for each question.
5. Do not use correction fluid/tape or highlighters.
6. The use of calculator is **NOT** allowed.

Section	Maximum Mark	Marks Obtained
Paper 1 (Booklet B)	25	

* This booklet consists of 10 pages (including this cover page).

Questions 16 to 20 carry 1 mark each. Write your answers in the spaces provided. For questions which require units, give your answers in the units stated.

Do not write
in this space

All diagrams in this paper are not drawn to scale unless stated otherwise.

(5 marks)

16. Find the value of $5 + 8 \div (7 - 3) \times 11$.

Ans: _____

17. The table below shows the number of pets each student keeps at home.

Number of pets per student	0	1	2	3
Number of students	62	50	25	10

How many students keep at least 2 pets at home?

Ans: _____

18. The cost of a bag is increased from \$40 to \$50. What is the percentage increase in the cost of the bag?

Ans: _____ %

19. Mr Tan was at work from 6.45 a.m. to 3.35 p.m. How long did he spend at work?

Do not write in this space

Ans: _____ h _____ min

20. PR, TR and SQ are straight lines. Find $\angle PQS$.

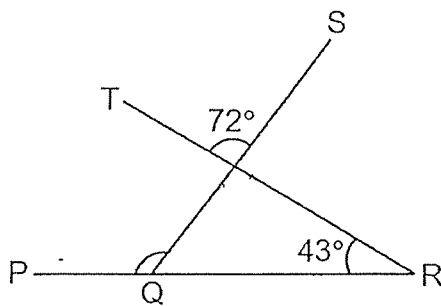

Ans: _____ °

Questions 21 to 30 carry 2 marks each. Show your workings clearly in the space provided for each question and write your answers in the spaces provided. For questions which require units, give your answers in the units stated.

Do not write in this space

All diagrams in this paper are not drawn to scale unless stated otherwise.

(20 marks)

21. (a) Write down all the common factors of 16 and 24.

Ans: (a) _____

(b) Find the sum of ^{all} the common factors of 16 and 24.

(b) _____

22. The square grid below shows the positions of points A, B, C, D and E.

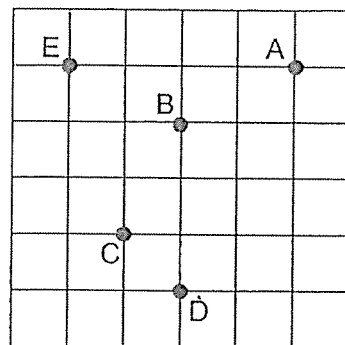

(a) Point _____ is south-east of point _____.

(b) Point _____ is east of point _____.

23. The chairs in a school hall were arranged in rows. Each row had the same number of chairs. Xiao Ming sat on one of the chairs. There were 8 chairs to his right and 9 chairs to his left. There were 6 rows in front of him and 5 rows of chairs behind him. How many chairs were there in the school hall?

Do not write
in this space

Ans: _____

24. Mary had a bag of flour. She used $\frac{1}{4}$ of it to bake some muffins and $\frac{2}{5}$ of the remainder to bake some pies. She had $\frac{1}{5}$ kg of flour left. What was the amount of flour she had at first?

Ans: _____ kg

25. Thiran and Nick had some erasers each. After Thiran gave $\frac{1}{5}$ of his erasers to Nick, the ratio of Nick's new number of erasers to Thiran's remaining number of erasers is 3 : 1. Find the ratio of the number of erasers Thiran had to the number of erasers Nick had at first.

Do not write
in this space

Ans: _____

26. The table below shows the number of points that a customer could earn from the amount spent at a shop.

Amount Spent (\$)	Number of Points Earned
Every \$10 spent	100 points

- (a) Hakim spent \$98 at the shop. How many points did he earn?

Ans: (a) _____

- (b) A voucher worth \$5 is given for every 1000 points earned. Amy received three \$5 vouchers at the shop. What was the minimum amount of money she had spent to earn these vouchers?

Ans: (b) \$ _____

27. The solid below is made up of 9 cubes. The front view is shown.

Do not write in this space

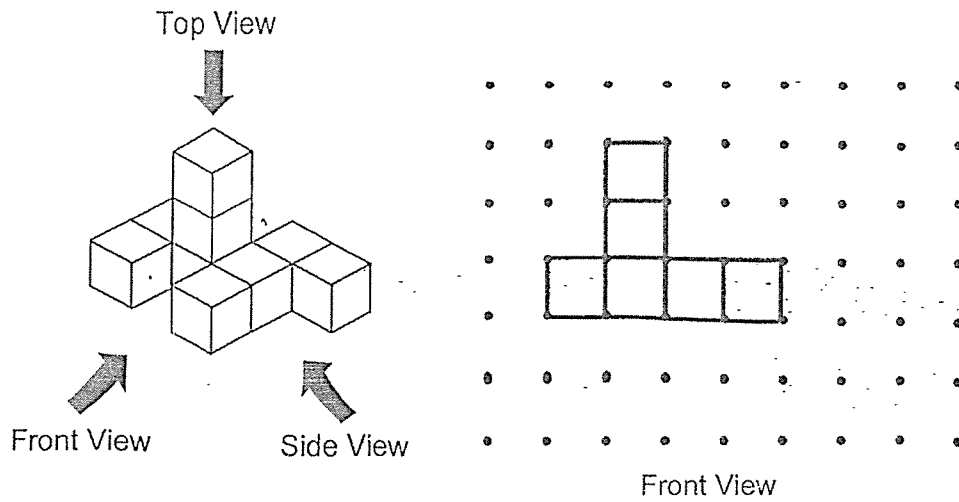

(a) Draw the top view of the solid on the grid.

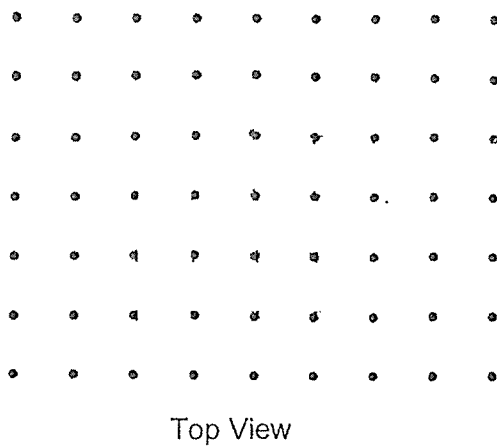

(b) What is the maximum number of unit cubes that can be added without changing the front view and side view of the solid?

Ans: (b) _____



28. The square grid shows line AB.

Do not write
in this space

- (a) AB is one side of a triangle with $\angle ABC = 90^\circ$ and the length of BC is half of the length of AB. Draw triangle ABC.
- (b) AB is also the side of a rhombus ABDE. Draw rhombus ABDE.

Use a pencil to draw your diagrams and label them clearly.

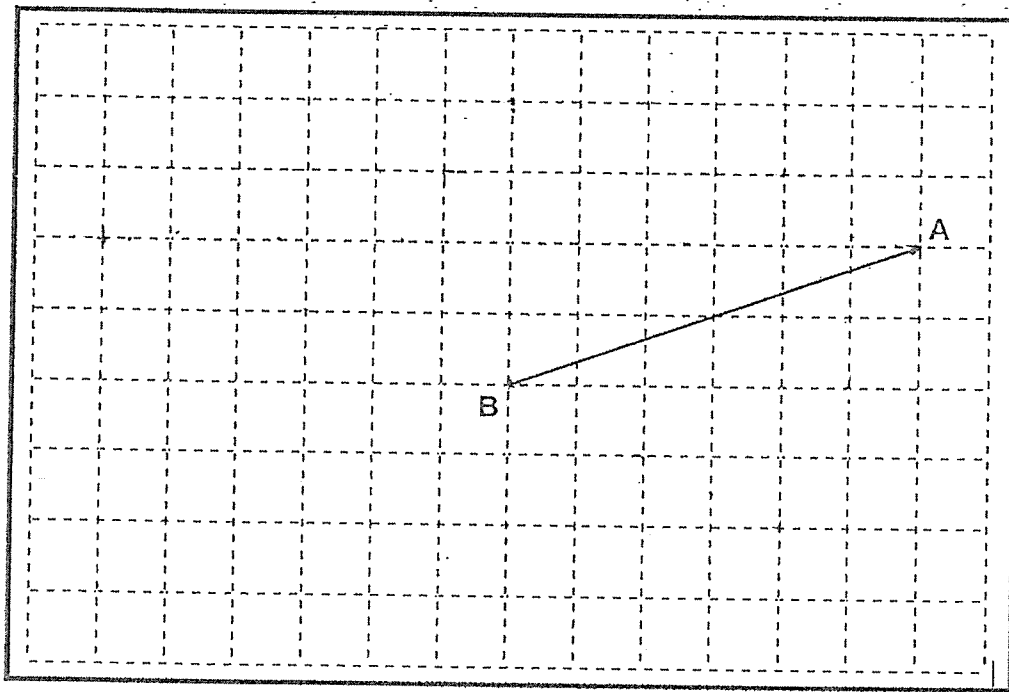

29. EFGH is a parallelogram and HGRS is a rhombus. FS is a straight line. Find $\angle GRS$.

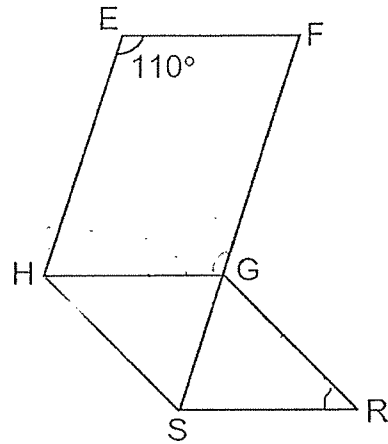

Do not write
in this space

Ans: _____ $^\circ$



30. The figure below is formed by 3 identical semi-circles. XY is a straight line of 30 cm. Find the area of the figure. Leave your answer in terms of π . Do not write in this space

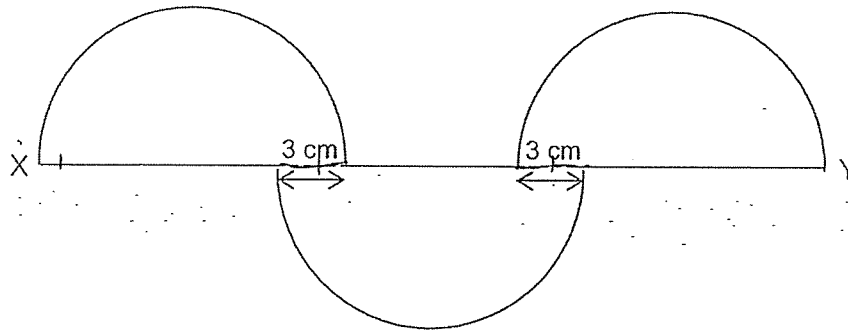

Ans: _____ cm²

End of paper
Have you checked your work?



ROSYTH SCHOOL
2025 PRELIMINARY EXAMINATION
MATHEMATICS
PRIMARY 6
PAPER 2

Name: _____

Register No. _____

Class: Pr 6 _____

Date: 26 August 2025

Parent's Signature: _____

Time: 1 h 30 min

Instructions to Pupils:

1. Do not turn over this page until you are told to do so.
2. Follow all instructions carefully.
3. Answer all questions.
4. Use a dark blue or black ballpoint pen to write your answers in the space provided for each question.
5. The use of an approved calculator is allowed.
6. Do not use correction fluid/tape.
7. Do not use highlighters on any part of your answers.

Questions	Maximum Mark	Marks Obtained
Q 1 to 5	10	
Q 6 to 17	45	

Section	Maximum Mark	Marks Obtained
Paper 1	45	
Paper 2	55	
Total	100	

* This booklet consists of 17 pages (including this cover page)

Questions 1 to 5 carry 2 marks each. Show your working clearly in the space provided for each question and write your answers in the spaces provided. For questions which require units, give your answers in the units stated.

(10 marks)

All diagrams in this paper are not drawn to scale unless stated otherwise.

Do not write
in this space

1. The table shows the ages of 3 children.

Name	Age (years old)
Sally	w
Mandy	$(w + 2)$
Rick	$(w + 4)$

The sum of the 3 children are 30 years old. How old is the eldest child?

Ans: _____

2. At 10 45, Siti started cycling at 24 km/h from her home to a park, 12 km away from her home. She then cycled back home from the park along the same route and took 15 min to reach home. What was Siti's average speed for the whole journey?

Ans: _____ km/h

3. The figure below is formed by overlapping a square BGFE and a rectangle ABCD. AEF is a straight line. The area of the square is 100 cm^2 . Point C is the centre of the square and E is the mid-point of DC. Find the unshaded area of the figure.

Do not write
in this space

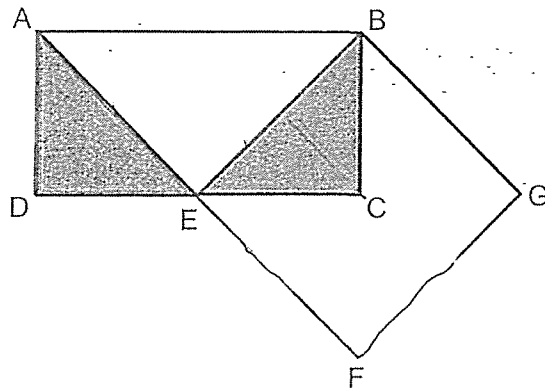

Ans: _____ cm^2



4. ABCD is a trapezium. AB is parallel to DC and XY is a straight line. Find $\angle CDY$.

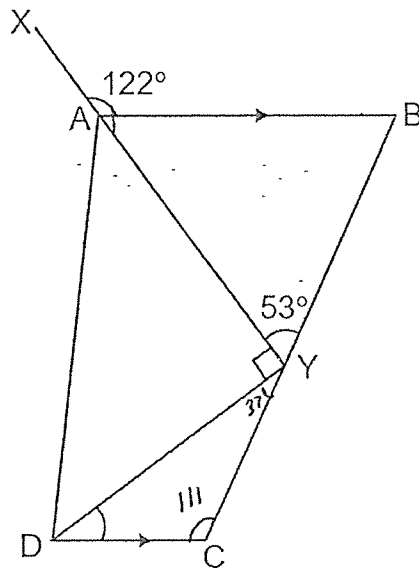

Do not write
in this space

Ans: _____^o

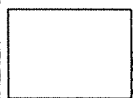

5. Some boxes were used to pack 504 plates. Each box contained either 8 big plates or 12 small plates. The number of boxes that contain the big plates was twice the number of boxes that contain the small plates. What was the number of boxes used to pack all the small plates?

Do not write
in this space

Ans: _____

For Questions 6 to 17, show your working clearly in the space provided for each question and write your answers in the spaces provided. The number of marks available is shown in brackets [] at the end of each question or part-question. For questions which require units, give your answers in the units stated.
(45 marks)

Do not write
in this space

6. Tom had some amount of money. He spent \$105 on some markers and spent $\frac{1}{5}$ of the remaining money on some pens. The rest of the money was spent on some notebooks. The amount of money spent on the notebooks was $\frac{1}{2}$ of the total amount of money he had at first. How much money did he have at first?

Ans: _____ [3]

7. Ali baked some cookies. He filled 2 types of cookie tins, large tins and small tins with the cookies he baked. He filled 2 large tins and 7 small tins with 5 kg 100 g of cookies. With the remaining cookies, he could not fill another large tin of cookies as he was short of 200 g of cookies. Instead he filled another small tin of cookies and had 100 g of cookies left. How many kilograms of cookies did he bake?

Do not write
in this space

Ans: _____ [3]

8. The bar graph below shows the ticket prices for the museums. The pie chart shows the number of tickets sold on a Sunday by each museum. The number of tickets sold by the Science Museum is twice the number of tickets sold by the Art Museum. The Toy Museum sold half of the total number of tickets sold on Sunday.

Do not write in this space

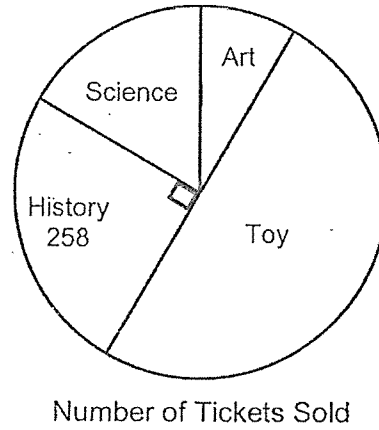
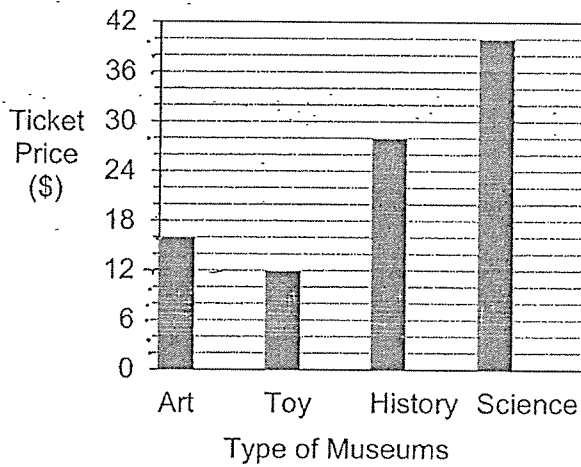

- (a) How many tickets were sold by the Art Museum?

Ans: (a) _____ [1]

- (b) Which museum collected the most money from the sale of the tickets?
What was the amount of money?

Ans: (b) Museum _____ [1]

Amount _____ [1]

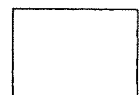

9. Two rectangular tanks are shown below. $\frac{2}{3}$ of Tank A and $\frac{1}{2}$ of Tank B were filled with water at first.

Do not write in this space

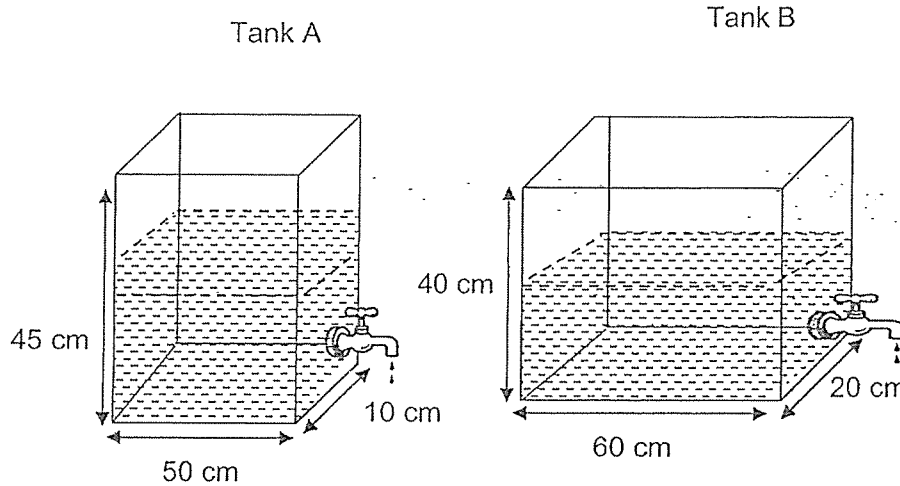

Water from both taps were then turned on at the same time. Water from both taps flowed out at the same rate of 1 litre per minute. What was the height of the water level in tank B when the water in tank A was emptied out?

Ans: _____ [3]

10. MZY is an isosceles triangle, where $YZ = YM$. WX is parallel to ZY and ZN is a straight line. $\angle ZYM = 132^\circ$ and $\angle XYN = 97^\circ$.

Do not write
in this space

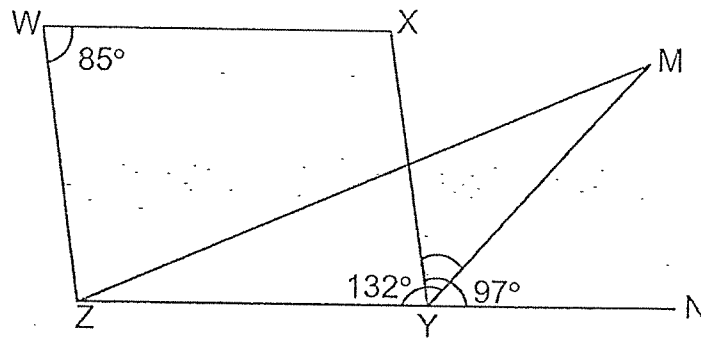

- (a) Find $\angle XYM$.

Ans: (a) _____ [2]

- (b) Circle the words that describe WXYZ in the statement: [1]

WXYZ (is / is not) a parallelogram because WZ (is / is not) parallel to XY.

11. Alice had 580 stickers and Karen had 20 stickers. Then both of them bought an equal number of stickers. As a result, Alice had 5 times as many stickers as Karen.

Do not write in this space

(a) How many stickers did Karen have after she bought the stickers?

Ans: (a) _____ [2]

(b) How many more stickers would Karen need to buy to have twice the number of stickers as Alice?

Ans: (b) _____ [2]



12. Mdm Siti had a box of beads. 65% of the beads were plastic beads and the rest were glass beads. Mdm Siti added 288 plastic beads and glass beads into the box.
In the end, 75% of the beads in the box were plastic beads and the number of glass beads was twice the number of glass beads at first.
- (a) What is the ratio of the number of plastic beads Mdm Siti had at first to the number of plastic beads Mdm Siti had in the end?

Do not write
in this space

Ans: (a) _____ [2]

- (b) How many glass beads did Mdm Siti add into the box?

Ans: (b) _____ [2]

13. The graph below shows the number of cakes baked by Oven A and Oven B. There was an order for 540 cakes to be baked. In the first 30 minutes, cakes were baked in both Oven A and Oven B. Then, Oven A broke down. In the next 2 hours, only Oven B continued to bake cakes at the same rate.

Do not write in this space

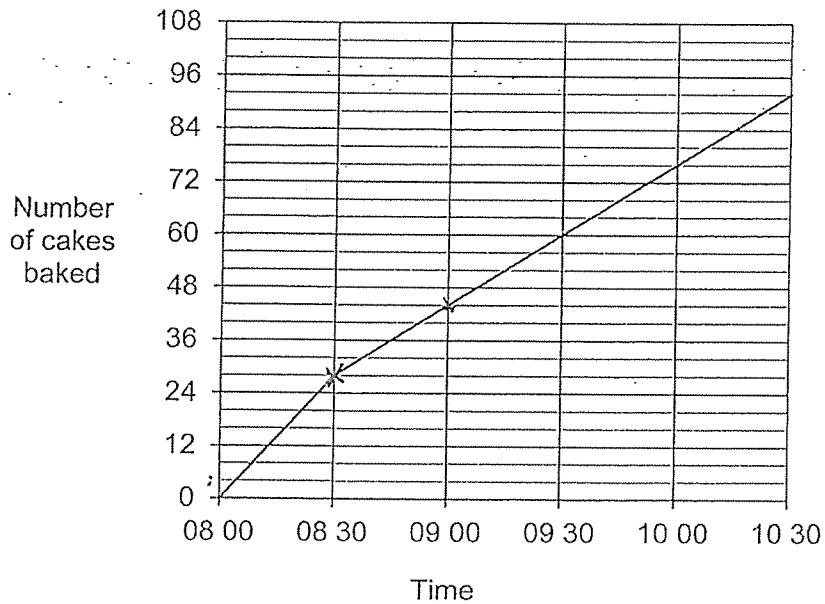

- (a) How many cakes could Oven A bake in one hour?

Ans: (a) _____ [2]

- (b) At what time would Oven B complete the order of baking the 540 cakes?

Ans: (b) _____ [2]



14. There are 7 small identical rectangles in a large rectangle ABCD as shown. The length of each small rectangle is 6 cm. What is the total area of the shaded parts?

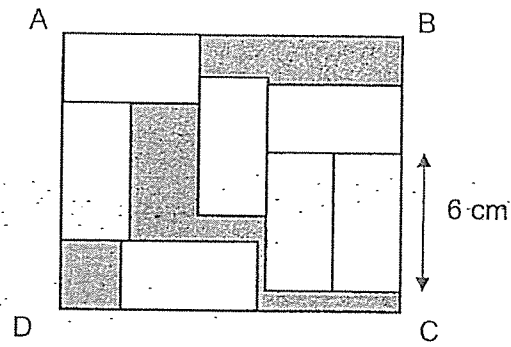

Do not write
in this space

Ans: _____ [4]



15. ABCD is a square and ABR is an equilateral triangle. BD is a straight line and is parallel to RP.

Do not write in this space

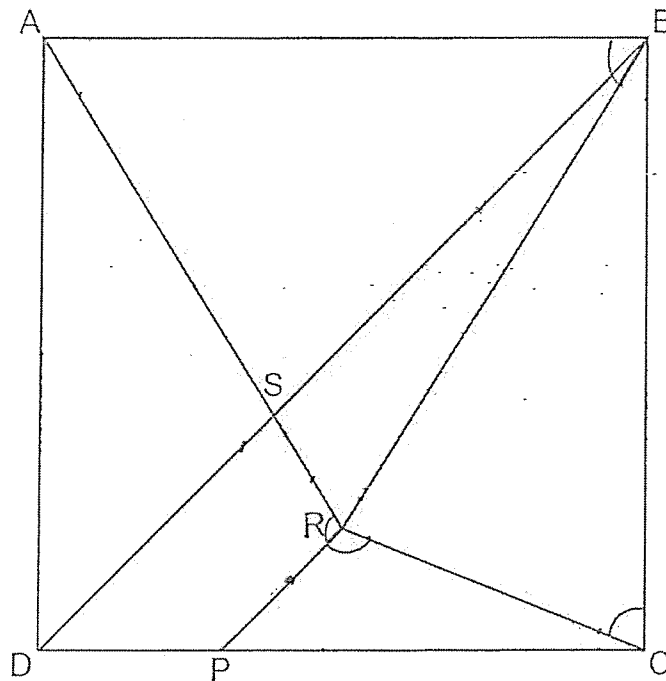

- (a) Find $\angle BCR$.

Ans: (a) _____ [2]

- (b) Find $\angle CRP$.

Ans: (b) _____ [2]



16. The first four figures of a pattern are shown below.

Do not write
in this space

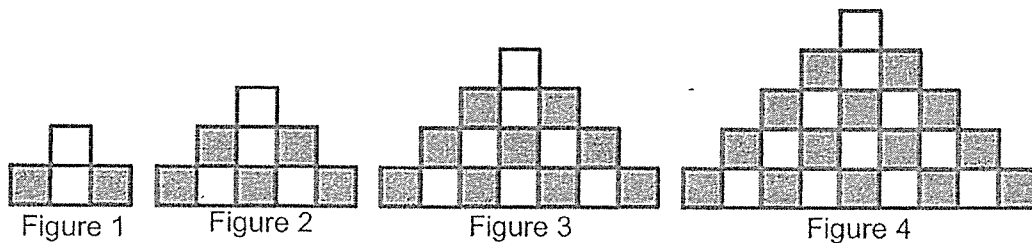

- (a) The table shows the number of white and grey squares used for the first four figures. Complete the table for Figure 5.

Figure Number	1	2	3	4	5
Number of white squares	2	4	7	11	
Number of grey squares	2	5	9	14	
Total number of squares	4	9	16	25	

[1]

- (b) A figure in the pattern has 144 squares in total. What is the figure number?

Ans: (b) _____ [1]

- (c) Another figure in the pattern has 30 more grey squares than white squares. How many white squares are there in this figure?

Ans: (c) _____ [3]



17. Michael bought 17 packets of muffins and 5 boxes of tarts as presents. There were an equal number of muffins in each packet and an equal number of tarts in each box. The number of tarts in one box is 9 more than the number of muffins in one packet. 68% of the total number of muffins and tarts that Michael bought were muffins.

Do not write
in this space

- (a) How many muffins did Michael buy altogether?

Ans: (a) _____ [4]

- (b) Find the ratio of the number of muffins in one packet to the number of tarts in one box. Give your answer in the simplest form.

Ans: (b) _____ [1]

End of paper
Have you checked your work?

SCHOOL : ROSYTH PRIMARY SCHOOL

LEVEL : PRIMARY 6

SUBJECT : MATH

TERM : 2025 PRELIM EXAM

BOOKLET A

Q1	Q2	Q3	Q4	Q5	Q6	Q7	Q8	Q9	Q10
1	1	1	3	3	2	1	3	4	4
Q11	Q12	Q13	Q14	Q15					
2	3	2	4	3					

BOOKLET B

Q16	$5 + 8 \div (7 - 3) \times 11 = 5 + 8 \div 4 \times 11 = 5 + 2 \times 11 = 5 + 22 = 27.$ ANS : 27
Q17	$25 + 10 = 35.$ ANS : 35
Q18	$\frac{50-40}{40} = \frac{10}{40} \times 100\% = 25\%.$ ANS : 25%
Q19	$8 \text{ hours} + 50 \text{ minutes} \rightarrow 8 \text{ Hours } 50 \text{ minutes}$ <p style="text-align: center;"> ----- ----- </p> <p>6.45 a.m. 2.45 p.m. 3.35 p.m. ANS : 8 h 50 min</p>
Q20	$\angle PQR = 72^\circ + 43^\circ = 115^\circ$ ANS : 115°
Q21	$24 = \underline{1} \times 24 = \underline{2} \times 12 = 3 \times \underline{8} = \underline{4} \times 6,$ $16 = \underline{1} \times 16 = \underline{2} \times \underline{8} = \underline{4} \times 4,$ Sum of common factors = $1 + 2 + 4 + 8 = 15$ ANS: (a) 1, 2, 4, 8 (b) 15
Q22	(a) Point <u>D</u> is south-east of point <u>C</u> . (b) Point <u>A</u> is east of point <u>E</u> . ANS : (a) D, C (b) A, E
Q23	There were $(8 + 1 + 9) \times (6 + 5 + 1) = 18 \times 12 = 216.$ ANS : 216 chairs

Q24	<p>Fraction of flour left = $\left(1 - \frac{1}{4}\right) \times \left(1 - \frac{2}{5}\right) = \frac{3}{4} \times \frac{3}{5} = \frac{9}{20}$, $\frac{9}{20} \rightarrow \frac{1}{5}$ kg, $1 \rightarrow \frac{1}{5} \times \frac{20}{9} = \frac{4}{9}$ kg.</p> <p style="text-align: right;">ANS : $\frac{4}{9}$ kg</p>												
Q25	<p>Working backwards,</p> <table style="width: 100%; border-collapse: collapse;"> <thead> <tr> <th style="text-align: left; border-bottom: 1px solid black;">Ratio of number of eraser</th> <th style="text-align: center; border-bottom: 1px solid black;">Thiran</th> <th style="text-align: center; border-bottom: 1px solid black;">Nick</th> </tr> </thead> <tbody> <tr> <td>At the end (1: 3 \rightarrow)</td> <td style="text-align: center;">4</td> <td style="text-align: center;">12</td> </tr> <tr> <td>Erasers Transfer</td> <td style="text-align: center;">1</td> <td style="text-align: center;">-1</td> </tr> <tr> <td>At first</td> <td style="text-align: center;">5</td> <td style="text-align: center;">11</td> </tr> </tbody> </table> <p style="text-align: right;">ANS : 5 : 11</p>	Ratio of number of eraser	Thiran	Nick	At the end (1: 3 \rightarrow)	4	12	Erasers Transfer	1	-1	At first	5	11
Ratio of number of eraser	Thiran	Nick											
At the end (1: 3 \rightarrow)	4	12											
Erasers Transfer	1	-1											
At first	5	11											
Q26	<p>(a) $98 \div 10 = 9$ R 8, $9 \times 100 = 900$. (b) Minimum amount of money spent $= 3 \times 1000 \div 100 \times \\$10 = \\$300$</p> <p style="text-align: right;">ANS : (a) 900 (b) \$300</p>												
Q27	<p>(a) Top view:</p> <div style="text-align: center;"> </div> <p>(b) Minimum number of unit cubes can be added without changing the front view and side view of the solid is 5 as shown.</p> <div style="display: flex; justify-content: space-around;"> <div style="text-align: center;"> </div> <div style="text-align: center;"> </div> </div> <p style="text-align: right;">ANS : (a) See figure (b) 5</p>												

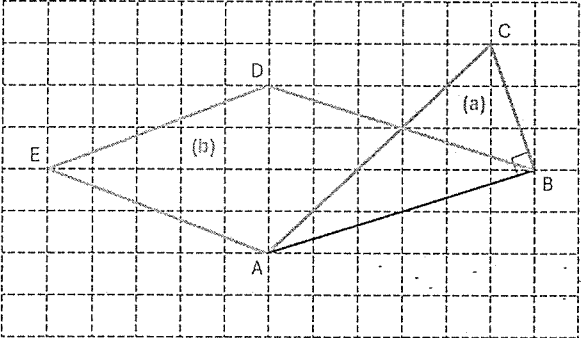
Q28	 <p>ANS : (a), (b) See figure</p>
Q29	<p>From parallelogram EFGH, $\angle FGH = \angle FEH = 110^\circ$. From rhombus HGRS, $\angle RGS = \angle SRG = \angle FGH = (180^\circ - 2 \times 70^\circ) \div 2 = 40^\circ$</p> <p>ANS : 40°</p>
Q30	<p>Radius of the semi-circle = $(30 + 3 + 3) \div 6 = 36 \div 6 = 6$. Area of the figure = $1.5 \times \pi \times 6^2 = 1.5 \times 36\pi = 54\pi \text{ cm}^2$.</p> <p>ANS : $(54\pi) \text{ cm}^2$</p>

PAPER 2

Q1	<p>$w + (w + 2) + (w + 4) = 3w + 6 = 30 \Rightarrow 3w = 30 - 6 = 24$, $\therefore w = 24 \div 3 = 8$, and hence, $w + 4 = 8 + 4 = 12$.</p> <p>ANS : 12 years old</p>
Q2	<p>Total distance cycles = $12 \times 2 = 24 \text{ km}$. Total time taken = $12 \div 24 + 15 \div 60 = 0.5 + 0.25 = 0.75 \text{ hours}$. Average speed for the whole journey = $24 \div 0.75 = 32 \text{ km/h}$.</p> <p>ANS : 32 km/h</p>
Q3	<p>Area of triangle BCE = $\frac{1}{4} \times 10^2 = 25 \text{ cm}^2$. \therefore Unshaded area of the figure = $5 \times 25 = 125 \text{ cm}^2$.</p> <p>ANS : 125 cm^2</p>
Q4	<p>In triangle ABY, $\angle BAY = 180^\circ - 122^\circ = 58^\circ$, and, $\angle ABY = 180^\circ - 58^\circ - 53^\circ = 69^\circ$. On straight line BYC, $\angle DYC = 180^\circ - 90^\circ - 53^\circ = 37^\circ$, and, Since AB // DC, $\angle DCY = 180^\circ - 69^\circ = 111^\circ$. Hence, in triangle DCY, $\angle YDC = 180^\circ - 111^\circ - 37^\circ = 32^\circ$.</p> <p>ANS : 32°</p>

Q5	<p>For a group of 2 boxes containing 8 big plates each and 1 box containing 12 small plates, the total number of plates = $2 \times 8 + 1 \times 12 = 28$.</p> <p>Number of boxes containing small plates = $504 \div 28 = 18$.</p> <p>ANS: 18</p>
Q6	<p>$3u = 105$, $u = 105 \div 3 = 35$</p> <p>Tom has $35 \times 8 = 280$ at first.</p> <p>ANS: \$280</p>
Q7	<p>Difference in weight of cookies in a large tin and a small tin = $200 + 100 = 300g$.</p> <p>Weight in a small tin = $\frac{5100 - 2 \times 300}{2 + 7} = \frac{5100 - 600}{9} = \frac{4500}{9} = 500g$.</p> <p>Remaining cookies weigh $500 + 100 = 600g$.</p> <p>Total weight of cookies baked = $5100 + 600 = 5700g = 5.7kg$.</p> <p>ANS: 5.7 kg</p>
Q8	<p>(a) Number of Art Museum tickets sold = $258 \div 3 = 86$.</p> <p>(b) Art Museum: $86 \times 16 = 1376$ Science Museum: $172 \times 40 = 6880$ History Museum: $258 \times 28 = 7224$ Toy Museum: $516 \times 12 = 6192$ History Museum collected the most money = \$7,224.</p> <p>ANS: (a) 86 (b) Museum History, Amount \$7,224</p>
Q9	<p>Tank A</p> <p>Volume of water at first = $50 \times 10 \times 45 \times \frac{2}{3} = 15000 \text{ cm}^3 = 15l$.</p> <p>Tank B</p> <p>Volume of water at first = $60 \times 20 \times 40 \times \frac{1}{2} = 24000 \text{ cm}^3 = 24l$.</p> <p>Volume of water left = $24 - 15 = 9l$.</p> <p>Height of water level = $9000 \div (60 \times 20) = 7.5 \text{ cm}$.</p> <p>ANS: 7.5 cm</p>
Q10	<p>(a) $\angle XYM = 132^\circ + 97^\circ - 180^\circ = 49^\circ$</p> <p>(b) $\angle XYZ = 180^\circ - 97^\circ = 83^\circ$ $\angle XWZ = 85^\circ$ $\angle XYZ \neq \angle XWZ$</p>

	<p>Hence, WXYZ is not a parallelogram because WZ is not parallel to XY.</p> <p>ANS: (a) 49° (b) is not, is not</p>
Q11	<p>(a) Difference in stickers Alice and Karen had remains the same after both bought an equal number of stickers.</p> $5u - u = 4u = 580 - 20 = 560$ $u = 560 \div 4 = 140$ <p>In the end, Karen had = 140 stickers.</p> <p>(b) Number of stickers Karen needs = $140 \times 5 \times 2 - 140 = 140 \times 9 = 1260$</p> <p>ANS: (a) 140 (b) 1260</p>
Q12	<p>(a) $65\% : (100\% - 65\%) = 65\% : 35\% = 13 : 7$ $75\% : (100\% - 75\%) = 75\% : 25\% = 3 : 1 = 42 : 14$ Ratio of plastic beads Mdm Siti had at first to the number of plastic beads she had in the end = 13 : 42.</p> <p>(b) Beads Mdm Siti had: At First \rightarrow Plastic $13u$, Glass $7u$, Total $20u$ At the end \rightarrow Plastic $42u$, Glass $14u$, Total $56u$ Total number of beads added = $56u - 20u = 36u = 288$ $u = 288 \div 36 = 8$ Glass beads added = $14u - 7u = 7u = 7 \times 8 = 56$ Mdm Siti added 56 glass beads into the box.</p> <p>ANS: (a) 13 : 42 (b) 56</p>
Q13	<p>(a) Combine baking rate of Oven A and B = $28 \div \frac{1}{2} = 56$ Baking rate of Oven B alone = $(92 - 28) \div 2 = 64 \div 2 = 32$ Baking rate of Oven A alone = $56 - 32 = 24$</p> <p>(b) Remaining = $540 - 92 = 448$ $448 \div 32 = 14$ hours 14 hours after 10 30 is 00 30 the next day morning.</p> <p>ANS: (a) 24 (b) 00 30</p>

Q14 Length of small rectangle = 6 cm, and its width = $6 \div 2 = 3$ cm.
 Length of big rectangle = $6 + 3 + 6 = 15$ cm,
 and its width = $3 + 6 + 3 = 12$ cm.
 \therefore Total area of the shaded parts = $15 \times 12 - 7 \times 6 \times 3 = 54 \text{ cm}^2$.
 ANS : 54 cm^2

Q15 (a) $\angle ABR = 60^\circ$ (angle of equilateral triangle).
 $\angle CBR = 90^\circ - 60^\circ = 30^\circ$ (right angle of a square).
 $\therefore \angle BRC = (180^\circ - 30^\circ) \div 2 = 75^\circ$ (base angle of isosceles triangle).
 (b) $\angle BDC = 45^\circ$ (base angle of right-angled isosceles triangle).
 $\angle RPC = \angle BDC = 45^\circ$ (corresponding angles, $BD \parallel RP$).
 $\angle BCR = \angle BRC = 75^\circ$ (base angle of isosceles triangle).
 $\angle RCP = 90^\circ - 75^\circ = 15^\circ$ (right angle of a square).
 $\therefore \angle RPC = 180^\circ - 45^\circ - 15^\circ = 120^\circ$ (angle sum of a triangle).
 ANS : (a) 75°
 (b) 120°

Q16 (a)

Figure Number	1	2	3	4	5
Number of white squares	2	4	7	11	16
Number of grey squares	2	5	9	14	20
Total number of squares	4	9	16	25	36
Difference between the number of grey and white squares	0	1	2	3	4

In Figure 5, number of white squares = $11 + 5 = \underline{16}$,
 number of grey squares = $14 + 6 = \underline{20}$,
 Total number of squares = $16 + 20 = \underline{36}$.

(b) The figure number = $\sqrt{144} - 1 = 11$.

(c) \therefore The figure number is $30 + 1 = 31$.
 The number of white squares Ans : (a) 16, 20, 36
 = $1 + (1 + 2 + 3 + 4 + \dots + 30 + 31)$ (b) Figure 11
 = $1 + 0.5 \times 31 \times 32 = 1 + 496 = 497$. (c) 497

Q17

- (a) Assume the number of muffins in each packet is u .
Then, the number of tarts in each box is $(u + 9)$.

Description	Muffins	Tarts
Number of packets	17	5
Quantity per packet	u	$u + 9$
Total number of muffins / tarts bought	$17u$	$5u + 45$
	68%	32%

$$\therefore 17u : (5u + 45) = 68\% : 32\% = 17 : 8 = 17u : 8u,$$

$$\Rightarrow 8u = 5u + 45, 3u = 45, u = 15.$$

$$\text{Total number of muffins bought} = 17u = 17 \times 15 = 255.$$

- (b) Ratio of number of muffins in one packet to the number of tarts in one packet = $u : (u + 9) = 15 : (15 + 9)$
 $= 15 : 24 = 5 : 8.$

ANS: (a) 255

(b) 5 : 8

www.sgexam.com