

NANYANG PRIMARY SCHOOL

**MID-YEAR PRACTICE
2025**

PRIMARY 6

**MATHEMATICS
PAPER 1
(BOOKLET A)**

Total Duration for Booklets A and B: 1 hour

Additional materials: Optical Answer Sheet (OAS)

INSTRUCTIONS TO PUPILS

1. Do not turn over this page until you are told to do so.
2. Follow all instructions carefully.
3. Answer all questions.
4. Shade your answers in the Optical Answer Sheet (OAS) provided.
5. The use of calculators is **NOT** allowed.

Name: _____ ()

Class: Primary 6 ()

Questions 1 to 10 carry 1 mark each. Questions 11 to 15 carry 2 marks each.
For each question, four options are given. One of them is the correct answer.
Make your choice (1, 2, 3 or 4) and shade your answer on the Optical Answer Sheet.
(20 marks)

1. In the number line below, what is the value of Y?

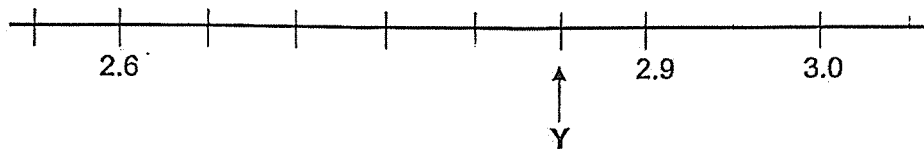

- (1) 2.85
- (2) 2.8
- (3) 2.75
- (4) 2.7

2 Find the value of $\frac{5}{6} \div \frac{1}{4}$.

- (1) $\frac{10}{3}$
- (2) $\frac{5}{24}$
- (3) $\frac{3}{10}$
- (4) $\frac{24}{5}$

3 Which of the following is the same as 25% of 20%?

(1) $\frac{1}{4} \times \frac{1}{5}$

(2) $\frac{3}{4} \times \frac{1}{5}$

(3) $\frac{1}{4} \times \frac{4}{5}$

(4) $\frac{3}{4} \times \frac{4}{5}$

4 The square grid below shows Triangle P. What type of triangle is Triangle P?

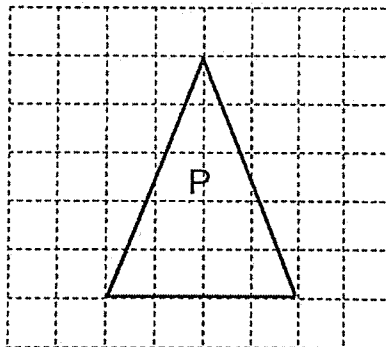

(1) Obtuse-angled triangle

(2) Right-angled triangle

(3) Equilateral triangle

(4) Isosceles triangle

5 In the square grid below, which shape is a rhombus?

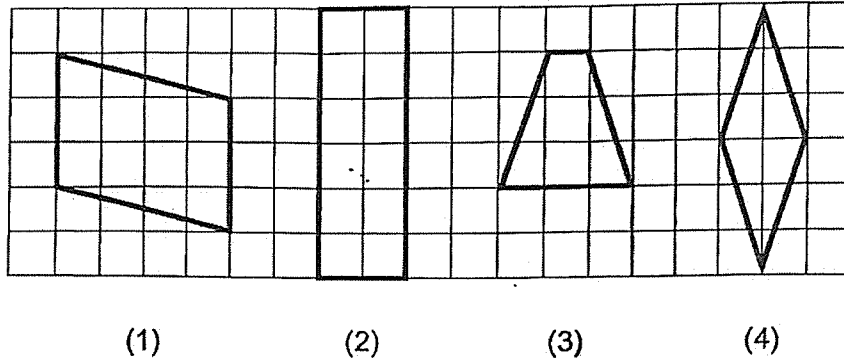

6 What is the area of triangle ABC as shown in the figure?

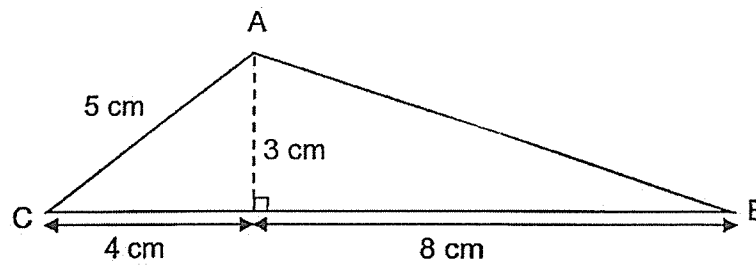

- (1) 18 cm^2
- (2) 20 cm^2
- (3) 30 cm^2
- (4) 36 cm^2

7 What is the area of a circle with diameter 60 cm?
(Take $\pi = 3.14$)

- (1) 94.2 cm²
- (2) 188.4 cm²
- (3) 2826 cm²
- (4) 11 304 cm²

- 8 Which of the following is likely to be the length of an approved scientific calculator for PSLE?

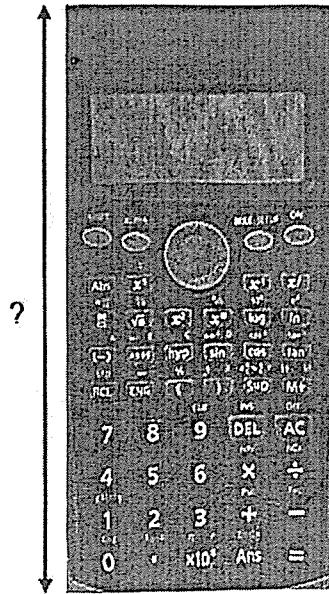

- (1) 0.018 m
- (2) 0.18 m
- (3) 1.8 m
- (4) 18 m

Use the information below to answer questions 9 and 10.

The bar graph below shows the number of cars sold from June to September.

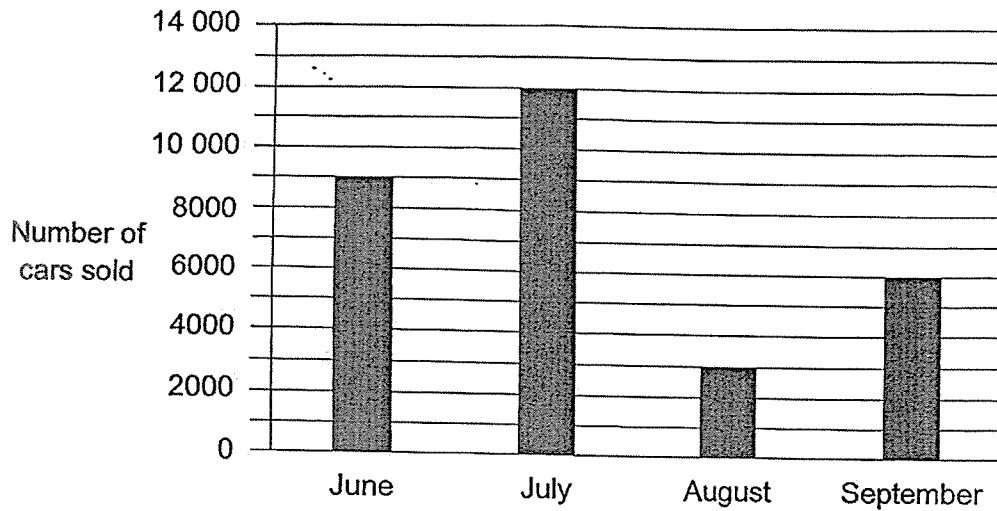

9 In which month was the number of cars sold half as many as the number of cars sold in September?

- (1) June
- (2) July
- (3) August
- (4) September

- 10 Which one of the following statements is true?
- (1) The number of cars sold in June was 8500.
 - (2) The number of cars sold in July is $\frac{3}{4}$ the number of cars sold in June.
 - (3) The increase in the number of cars sold from August to September was 9000.
 - (4) The total number of cars sold in June and August is the same as the number of cars sold in July.
- 11 Last month, a florist sold 800 roses. This month, she sold 1000 roses. What was the percentage increase in the number of roses sold?
- (1) 20%
 - (2) 25%
 - (3) 80%
 - (4) 200%

- 12 The figure below is made up of 3 identical quarter circles of radius 28 cm. Find its perimeter. (Take $\pi = \frac{22}{7}$)

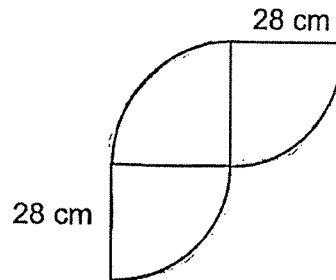

- (1) 132 cm
(2) 176 cm
(3) 188 cm
(4) 232 cm
- 13 A lollipop cost \$0.70. There were 80 lollipops in a box. Janie bought 8 such boxes of lollipops for her class party. How much did she spend on the lollipops?
- (1) \$408
(2) \$428
(3) \$448
(4) \$560

14 An empty rectangular tank was 40 cm long, 20 cm wide and 80 cm high. Mary poured some water into it and the water level reached a height of 30 cm. How many litres of water were there in the tank?

(1) 64 000

(2) 24 000

(3) 64

(4) 24

15 In a basket, $\frac{5}{9}$ of the fruits are apples and the rest are oranges. $\frac{3}{10}$ of the apples are green in colour. There are 15 green apples. How many fruits are there in the basket?

(1) 45

(2) 50

(3) 90

(4) 135

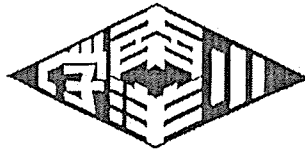

NANYANG PRIMARY SCHOOL

**MID-YEAR PRACTICE
2025**

PRIMARY 6

**MATHEMATICS
PAPER 1
(BOOKLET B)**

Total Duration for Booklets A and B: 1 hour

INSTRUCTIONS TO PUPILS

1. Do not turn over this page until you are told to do so.
2. Follow all instructions carefully.
3. Answer all questions.
4. Write your answers in this booklet.
5. The use of calculators is **NOT** allowed.

Name: _____ ()

Class: Primary 6 ()

Booklet B

/ 25

Please sign and return the paper the next day. Any queries should be raised at the same time when returning paper.

Questions 16 to 20 carry 1 mark each. Write your answers in the spaces provided. For questions which require units, give your answers in the units stated. (5 marks)

16 Express $3\frac{1}{4}$ as a decimal.

Ans: _____

17 The volume of a cube is 1000 cm^3 . Find the length of one edge of the cube.

Ans: _____ cm

18 6 unit cubes were stacked and glued together to form the solid below.

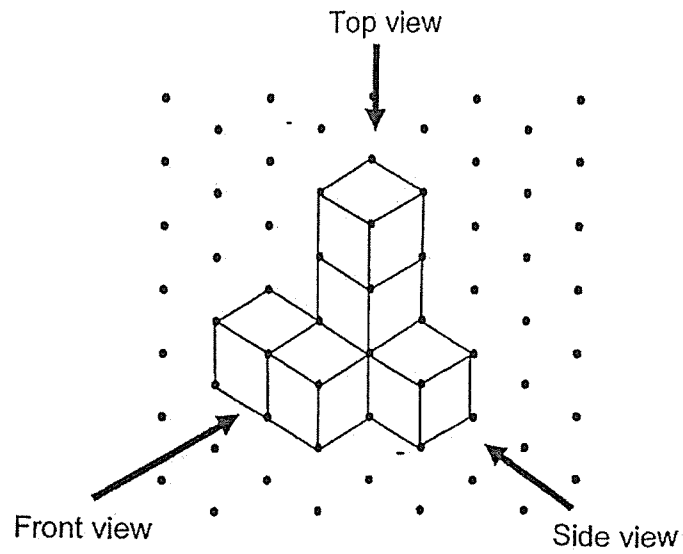

Draw the side view of the solid on the grid below.

Side View

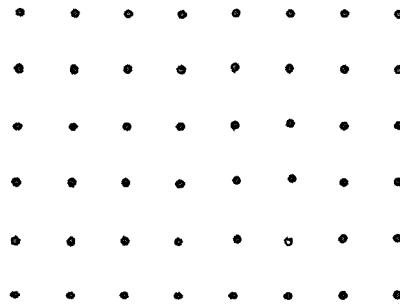

- 19 In the figure below, ACD and BCE are straight lines.
 $\angle ABE = 55^\circ$, $\angle DEB = 114^\circ$ and $\angle DAB = 90^\circ$. Find $\angle ADE$.

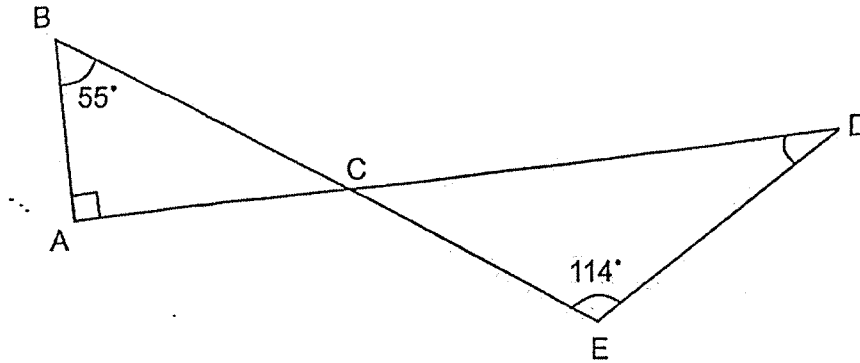

Ans: _____°

- 20 In the figure below, WXYZ is a trapezium and WX is parallel to ZY.
 $\angle WXY = 56^\circ$ and $\angle WZY = 68^\circ$. Find $\angle XWZ$.

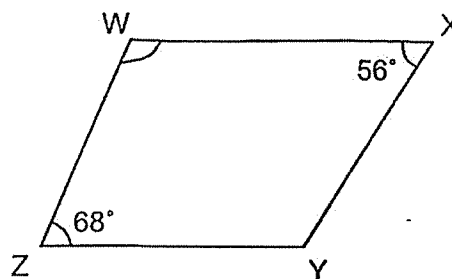

Ans: _____°

Questions 21 to 30 carry 2 marks each. Show your working clearly and write your answers in the spaces provided. For questions which require units, give your answers in the units stated. (20 marks)

- 21 In the figure below, JKN is an isosceles triangle and $KLMN$ is a parallelogram. JNM is a straight line and $JK = KN$. $\angle KNM = 110^\circ$. Find $\angle JKN$.

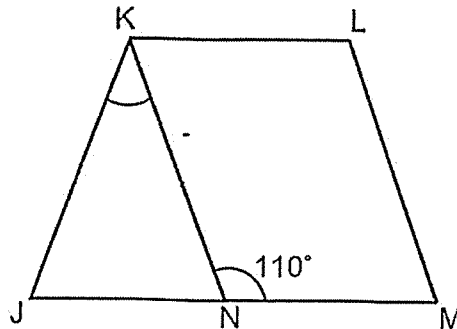

Ans: _____ °

- 22 Find the circumference of a circle of radius 5 cm. (Take $\pi = 3.14$)

Ans: _____ cm

- 23 The figure below is made up of 2 semicircles. XY is half of XZ.
XY = 14 cm. Find the area of the shaded part. (Take $\pi = \frac{22}{7}$)

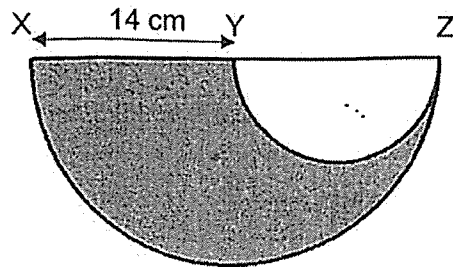

Ans: _____ cm²

- 24 A straight line EF is drawn on a square grid inside a box.

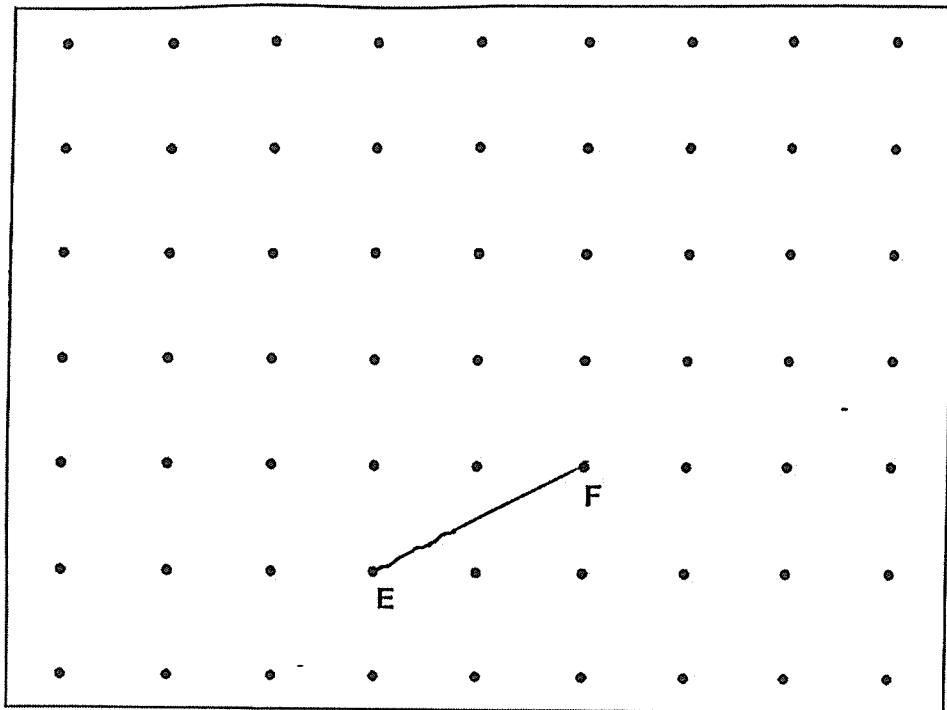

G is one of the dots inside the box. Draw two lines FG and EG to complete triangle EFG with $\angle EFG = 90^\circ$ and $EF = FG$.

- 25 A cuboid is 0.4 m long and 20 cm wide. It has a volume of 20 000 cm³. Find the height of the cuboid.

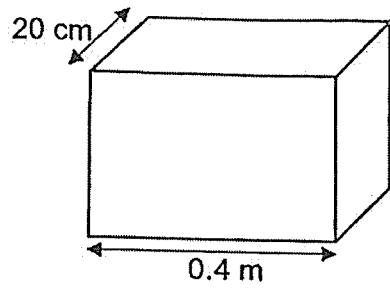

Ans: _____ cm

- 26 Two numbers add up to 364. One of the numbers is a 2-digit number and the other is a 3-digit number. What is the smallest possible difference between the two numbers?

Ans: _____

- 27 Use all the digits 7, 0, 4 and 5 to form
- (a) the smallest multiple of 10

Ans: (a) _____

- (b) the even number closest to 5000

Ans: (b) _____

- 28 Shanice had a bottle of shampoo. She used an equal amount of shampoo each day. At the end of the 7th day, $\frac{4}{5}$ of the bottle was left. At the end of the 15th day, the amount of shampoo left was 280 ml. What was the amount of shampoo in the bottle at first?

Ans: _____ ml

- 29 The block of wood shown below was dipped into a pail of paint. The block was then cut into 4 identical cubes along the dotted lines and taken apart. The total unpainted area of the 4 cubes was 150 cm².

What was the volume of each cube?

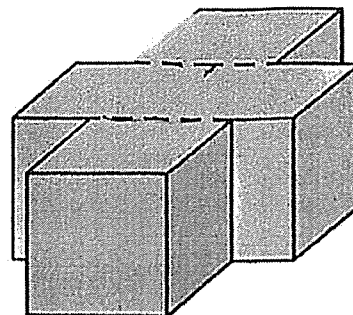

Ans: _____ cm³

- 30 Three girls used the same number of beads to make necklaces. Devi used $\frac{2}{5}$ of her beads, Esther used $\frac{3}{8}$ of hers and Farah used $\frac{2}{3}$ of hers. They had a total of 1440 beads at first. How many beads did each girl use?

Ans: _____

End of Paper

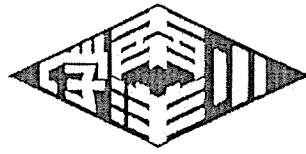

NANYANG PRIMARY SCHOOL

**MID-YEAR PRACTICE
2025**

PRIMARY 6

**MATHEMATICS
PAPER 2**

Duration: 1 hour 30 minutes

INSTRUCTIONS TO PUPILS

1. Do not turn over this page until you are told to do so.
2. Follow all instructions carefully.
3. Answer all questions.
4. Write your answers in this booklet.
5. The use of an approved calculator is allowed.

Name: _____ ()

Class: Primary 6 ()

Parent's Signature: _____

Booklet A	/ 20
Booklet B	/ 25
Paper 2	/ 55
Total	/ 100

Please sign and return the paper the next day. Any queries should be raised at the same time when returning paper.

Questions 1 to 5 carry 2 marks each. Show your working clearly and write your answers in the spaces provided. For questions which require units, give your answers in the units stated. (10 marks)

1 The bar graph below shows the number of stamps collected by 4 boys.

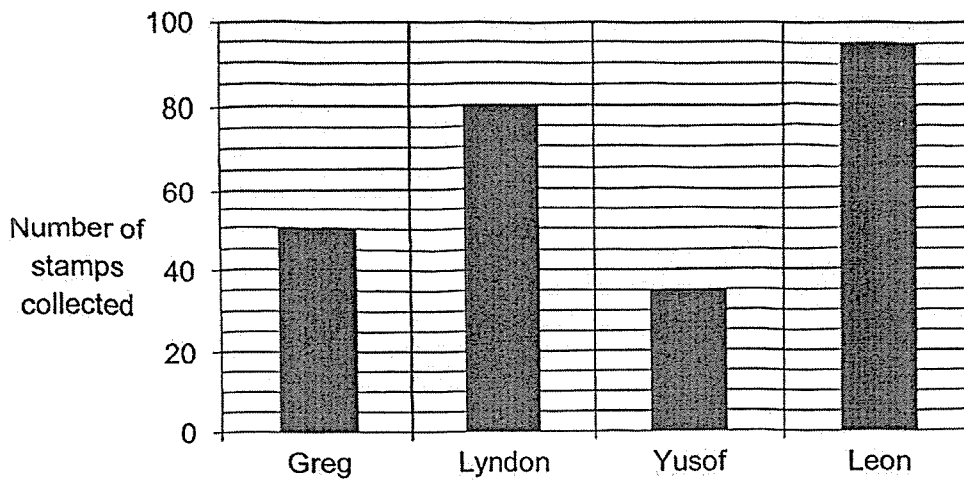

Complete the table with the number of stamps collected by each boy.

Name	Number of stamps collected
Greg	50
Lyndon	
Yusof	35
Leon	

- 2 A bicycle wheel of diameter 80 cm made 3 complete turns. Find the distance covered. (Take $\pi = 3.14$)

Ans: _____ cm

- 3 Mr Tan bought a laptop. The price of the laptop before GST was \$2580. He had to pay GST of 9% on the price of the laptop. What was the amount of GST he had to pay?

Ans: \$ _____

- 4 A machine started printing brochures at 8 a.m. on Wednesday at a rate of 800 brochures per hour. After every 5 hours of printing, it would be stopped for an hour to cool down. How many brochures were printed by 6 a.m. the next day?

Ans: _____

- 5 Kendrik bought 4 different storybooks. The first storybook cost \$14 and the average cost of the remaining storybooks was $\frac{3}{7}$ of the cost of the first storybook. How much did he pay for all the storybooks?

Ans: \$ _____

For questions 6 to 17, show your working clearly and write your answers in the spaces provided. The number of marks available is shown in brackets [] at the end of each question or part-question. (45 marks)

- 6 The figure is made up of a rectangle and a triangle overlapping each other as shown. $\frac{1}{4}$ of the rectangle and $\frac{2}{5}$ of the triangle is unshaded. The area of the unshaded part of the figure is 57 cm^2 .

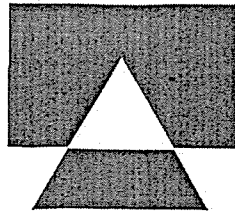

- (a) Find the area of the rectangle.

Ans: (a) _____ [1]

- (b) What fraction of the figure is unshaded?

Ans: (b) _____ [2]

- 7 In the figure below, PQRS is a rectangle and QRT is a right-angled triangle with sides measuring 30 cm, 40 cm and 50 cm. The perimeter of the shaded part is 174 cm.

What is the ratio of the area of the triangle to the area of the shaded part?
Give your answer in the simplest form.

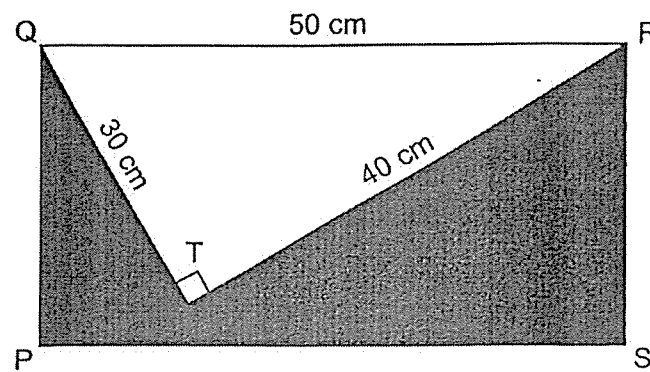

Ans: _____ [3]

- 8 Nurul and Peili went shopping together with a total sum of \$60. Nurul spent twice as much as Peili. The amount Peili had left was \$7 more than what she had spent. She had twice as much money left as Nurul. How much money did Nurul have at first?

Ans: _____ [3]

- 9 Suzi formed a solid using some 2-cm, 3-cm and 5-cm cubes. She used a total of 18 cubes to form the solid. The total volume of the solid was 707 cm^3 . How many 2-cm cubes did Suzi use?

Ans: _____ [3]

- 10 The following diagram shows a piece of paper QRST in the shape of a trapezium. $\angle TQR = 115^\circ$. The paper is folded along line UV which is parallel to QT.

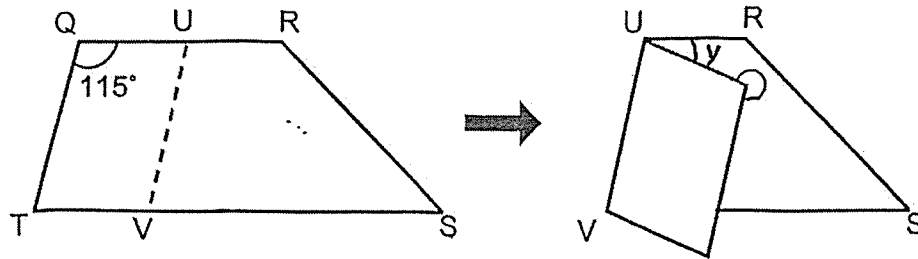

- (a) Find $\angle x$.

Ans: (a) _____ [1]

- (b) Find $\angle y$.

Ans: (b) _____ [2]

- 11 In the figure below, EFGH is a square. $\angle FKE = 106^\circ$ and $FE = EJ$. FKH and JKE are straight lines. Find $\angle KFJ$.

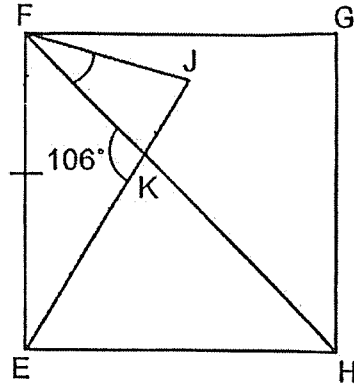

Ans: _____ [4]

- 12 At first, Lisa had a total of 66 blue and pink balloons. 17 pink balloons burst. She then increased the number of blue balloons by 75%. After that, Lisa had a total of 79 balloons. How many pink balloons did she have at first?

Ans: _____ [4]

- 13 A rectangular tank with a base area of 3500 cm^2 and a height of 80 cm was $\frac{1}{4}$ -filled with water at first. At 8 a.m., a tap was turned on and water was drained from the tank at the rate of 4 litres per minute. At 8.06 a.m., the tap was turned off.

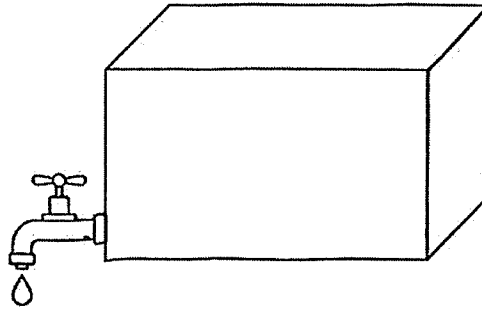

- (a) How much water was drained from the tank?

Ans: (a) _____ [1]

- (b) After the tap was turned off, how much more water was needed to fill the tank completely?

Ans: (b) _____ [3]

- 14 Six identical rectangular boxes can be stacked into a cupboard 0.9 m wide. Two arrangements are shown below. The first arrangement in Figure A leaves a 42-cm gap at the top. The second one in Figure B leaves a 10-cm gap at the top and another gap at the side.

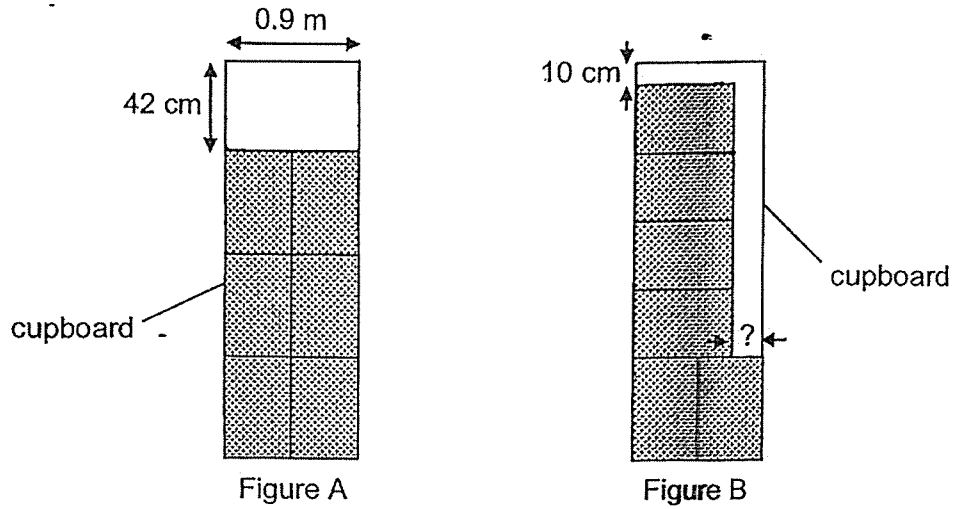

- (a) In the arrangement shown in Figure B, what is the width of the gap at the side?

Ans: (a) _____ [2]

- (b) What is the height of the cupboard in metres?

Ans: (b) _____ [2]

- 15 Karl had clips of four different colours. $\frac{1}{8}$ of the clips were white and $\frac{2}{7}$ of the remaining clips were red. He had an equal number of blue clips and yellow clips. Karl had 35 blue clips.

(a) How many red clips did he have?

Ans: (a) _____ [2]

- (b) Karl packed all the blue clips into small, medium, and large boxes. He filled each small box with 2 clips, each medium box with 3 clips and each large box with 6 clips. All the boxes were full and there was no clips left over. What was the least number of boxes used by Karl?

Ans: (b) _____ [2]

- 16 A symmetric figure is drawn on a rectangular piece of paper 20 cm by 15 cm as shown below. Its outline consists of a large semicircle, 2 smaller semicircles and 2 straight lines. (Take $\pi = 3.14$)

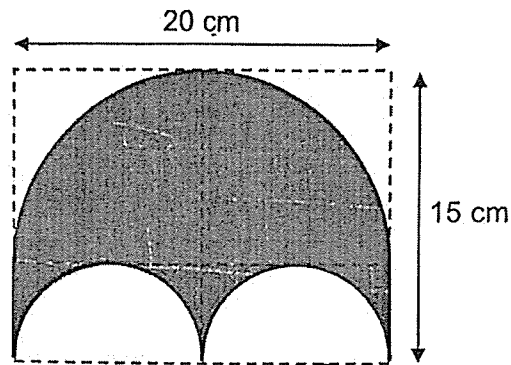

- (a) What is the area of the figure?

Ans: (a) _____ [3]

- (b) What is its perimeter?

Ans: (b) _____ [2]

17 The amount of money Kathy had to the amount of money Alice had was 3 : 4. After Kathy spent \$250 on a bag and gave \$50 to Alice, the ratio became 1 : 2.

(a) How much money did Alice have at first?

Ans: (a) _____ [3]

(b) How much money did Kathy have at the end?

Ans: (b) _____ [2]

End of Paper

SCHOOL : NANYANG PRIMARY SCHOOL

LEVEL : PRIMARY 6

SUBJECT : MATH

TERM : 2025 SA1

BOOKLET A

Q1	Q2	Q3	Q4	Q5	Q6	Q7	Q8	Q9	Q10
1	1	1	4	4	1	3	2	3	4
Q11	Q12	Q13	Q14	Q15					
2	3	3	4	3					

BOOKLET B

Q16	$3\frac{1}{4} = 3.25.$	ANS : 3.25
Q17	$\sqrt[3]{1000} = 10 \text{ cm}$	ANS : 10 cm
Q18		ANS : See figure
Q19	$\angle DCE = \angle ACB, \rightarrow 180^\circ - (\angle ADE + 114^\circ) = 180^\circ - (90^\circ + 55^\circ),$ $\rightarrow \angle ADE + 114^\circ = 90^\circ + 55^\circ$ $\therefore \angle ADE = 90^\circ + 55^\circ - 114^\circ = 31^\circ.$	ANS : 31°
Q20	$\angle XWZ = 180^\circ - 68^\circ = 112^\circ.$	ANS : 112°
Q21	$\angle KJN = \angle KNJ = 180^\circ - 110^\circ = 70^\circ.$ (interior \angle s, $WX \parallel ZY$) $\angle JKN = 180^\circ - \angle KJN - \angle KNJ = 180^\circ - 70^\circ - 70^\circ = 40^\circ.$	ANS : 40°
Q22	Circumference of the circle = $2 \times 3.14 \times 5 = 31.4 \text{ cm}.$	ANS : 31.4 cm

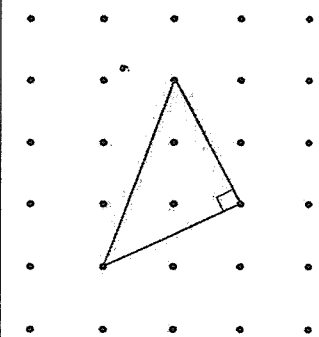
Q23	Area of the shaded part = $0.5 \times \frac{22}{7} \times (14^2 - 7^2) = 231 \text{ cm}^2$ ANS : 231 cm ²												
Q24	 ANS : See figure												
Q25	0.4 m = 40 cm. Height of cuboid = $20000 \div 40 \div 20 = 25 \text{ cm}$ ANS : 25 cm												
Q26	The 2-digit number = 99. The 3-digit number = $364 - 99 = 265$. Their difference = $265 - 99 = 166$. ANS : 166												
Q27	(a) The smallest multiple of 10 = 4570. (b) The even number closest to 5000 = 5074. ANS : (a) 4570 (b) 5074												
Q28	<table border="0" style="width: 100%; border-collapse: collapse;"> <thead> <tr> <th style="text-align: left;"><u>End of</u></th> <th style="text-align: center;"><u>Used</u></th> <th style="text-align: center;"><u>Left</u></th> <th style="text-align: left;"><u>End of</u></th> <th style="text-align: center;"><u>Used</u></th> <th style="text-align: center;"><u>Left</u></th> </tr> </thead> <tbody> <tr> <td>7th day</td> <td style="text-align: center;">$\frac{1}{5}$</td> <td style="text-align: center;">$\frac{4}{5}$</td> <td>15th day</td> <td style="text-align: center;">$\frac{15}{35} = \frac{3}{7}$</td> <td style="text-align: center;">280 ml</td> </tr> </tbody> </table> <p>$\therefore 1 - \frac{3}{7} = \frac{4}{7} \rightarrow 280 \text{ ml}, 1 \rightarrow 280 \times \frac{7}{4} = 490 \text{ ml}.$</p> <p>ANS : 490 ml</p>	<u>End of</u>	<u>Used</u>	<u>Left</u>	<u>End of</u>	<u>Used</u>	<u>Left</u>	7 th day	$\frac{1}{5}$	$\frac{4}{5}$	15 th day	$\frac{15}{35} = \frac{3}{7}$	280 ml
<u>End of</u>	<u>Used</u>	<u>Left</u>	<u>End of</u>	<u>Used</u>	<u>Left</u>								
7 th day	$\frac{1}{5}$	$\frac{4}{5}$	15 th day	$\frac{15}{35} = \frac{3}{7}$	280 ml								
Q29	The unpainted square surface of a cube = $150 \div 6 = 25 \text{ cm}^2$. The side of each cube = $\sqrt{25} = 5 \text{ cm}.$ Volume of each cube = $5^3 = 125 \text{ cm}^3.$ ANS : 125 cm ³												
Q30	Devi used $\frac{2}{5} = \frac{6}{15}$ of her beads, Esther used $\frac{3}{8} = \frac{6}{16}$ of her beads, and Farah used $\frac{2}{3} = \frac{6}{9}$ of her beads. $1440 \div (15 + 16 + 9) = 1440 \div 40 = 36,$ \therefore Each of the girls used $36 \times 6 = 216$ beads. ANS : 216 beads												

PAPER 2

Q1	Name	Number of stamps collected
	Greg	50
	Lyndon	80
	Yusof	35
	Leon	95
	ANS : 80, 95	
Q2	Distance covered = $3 \times 3.14 \times 80 = 753.6 \text{ cm}$. ANS : 753.6 cm	
Q3	GST amount = $\$2580 \times 9\% = \232.20 ANS : \$232.20	
Q4	Time lapsed = 22 hours. $22 \div 6 = 3 \text{ R } 4$ hours. Brochures printed = $(3 \times 5 + 4) \times 800 = 19 \times 800 = 15200$. ANS : 15200	
Q5	Average cost of the 3 remaining books = $\$14 \times \frac{3}{7} = \6 . Total cost of the 4 books = $\$14 + 3 \times \$6 = \$14 + \$18 = \$32$. ANS : \$32	
Q6	(a) Area of the rectangle = $57 \times 4 = 228 \text{ cm}^2$. (b) $\frac{1}{4} = \frac{2}{8}$ of the rectangle and $\frac{2}{5}$ of the triangle is unshaded. \therefore Fraction of the figure is unshaded = $\frac{2}{8+5-2} = \frac{2}{11}$. ANS : (a) 228 cm^2 (b) $\frac{2}{11}$	
Q7	Breadth of the rectangle = $(174 - 30 - 40 - 50) \div 2 = 27 \text{ cm}$. Area of triangle = $0.5 \times 30 \times 40 = 600 \text{ cm}^2$. Area of the shaded part = $50 \times 27 - 60 = 750 \text{ cm}^2$. Ratio of the area of triangle : area of the shaded part = $600 : 750 = 4 : 5$. ANS : 4 : 5	

Q8	<p>Assume Nurul had \$u left. Then,</p> <table border="0" style="margin-left: auto; margin-right: auto;"> <thead> <tr> <th></th> <th style="text-align: center;">Nurul</th> <th style="text-align: center;">Peili</th> <th style="text-align: center;">Total</th> </tr> </thead> <tbody> <tr> <td>At First</td> <td style="text-align: center;">\$(5u - 14)</td> <td style="text-align: center;">\$(4u - 7)</td> <td style="text-align: center;">\$60</td> </tr> <tr> <td>Spent</td> <td style="text-align: center;">\$(4u - 14)</td> <td style="text-align: center;">\$(2u - 7)</td> <td></td> </tr> <tr> <td>Left</td> <td style="text-align: center;">\$u</td> <td style="text-align: center;">\$2u</td> <td></td> </tr> </tbody> </table> <p>$\therefore (5u - 14) + (4u - 7) = 60, 9u = 60 + 21 = 81, u = 9.$ Nurul had $\\$(5u - 14) = \\$(5 \times 9 - 14) = \\$31$ at first.</p> <p>ANS: \$31</p>		Nurul	Peili	Total	At First	\$(5u - 14)	\$(4u - 7)	\$60	Spent	\$(4u - 14)	\$(2u - 7)		Left	\$u	\$2u	
	Nurul	Peili	Total														
At First	\$(5u - 14)	\$(4u - 7)	\$60														
Spent	\$(4u - 14)	\$(2u - 7)															
Left	\$u	\$2u															
Q9	<p>We note that volume of a 2-cm cube = 8 cm^3. Volume of a 3 cm-cube = 27 cm^3. Volume of a 5-cm cube = 125 cm^3.</p> <p>The largest possible number of 5-cm cubes = $707 \div 125 = 5 \text{ R } 82 \text{ cm}^3$.</p> <p>(i) For five (5) 5-cm cubes, we have remaining of $18 - 5 = 13$ blocks of combination of 2-cm and 3-cm cubes. The smallest volume of is $13 \times 8 = 104 \text{ cm}^3$ which is more than 82 cm^3. Thus five (5) 5-cm cubes is not a solution we are seeking.</p> <p>(ii) We consider next four (4) 5-cm cubes, we have remaining $18 - 4 = 14$ blocks of 3-cm and 2-cm cubes with a combined volume of $707 - 4 \times 125 = 207 \text{ cm}^3$.</p> <p>Assume a total of fourteen (14) 3-cm cubes, then, $14 \times 27 = 378, 378 - 207 = 171$ and $27 - 8 = 19$. The number of 2-cm cubes is thus $171 \div 19 = 9$. The number of 3-cm cubes is $14 - 9 = 5$. Solution is four (4) 5-cm, five (5) 3-cm and nine (9) 2-cm cubes.</p> <p>(iii) If there are three (3) 5-cm cubes, we have $18 - 3 = 15$ blocks with a combined volume of $707 - 3 \times 125 = 332 \text{ cm}^3$. Assume a total of thirteen (15) of 3-cm cubes, then, $15 \times 27 = 405, 405 - 332 = 73$ and $27 - 8 = 19$. The number of 2-cm cubes is $73 \div 19 = 3.84$, not an integer. \therefore Three (3) 5-cm cubes is also not a solution we are seeking.</p> <p>(iv) If there are two (2) 5-cm cube, we have $18 - 2 = 16$ blocks with a combined volume of $707 - 2 \times 125 = 457 \text{ cm}^3$. $16 \times 27 = 432 \text{ cm}^3 < 457 \text{ cm}^3$. No solution if there are two (2) 5-cm cubes. Check: $4 \times 125 + 5 \times 27 + 9 \times 8 = 707$.</p> <p>ANS: 9 2-cm cubes</p>																

Q10	<p>(a) $\angle x = \text{reflex } \angle TQU = 360^\circ - 115^\circ = 245^\circ$. ($\angle$ sum at a point) (b) $\angle QUV = 180^\circ - 115^\circ = 65^\circ$. (interior \angles, QT//UV) $\angle y = 180^\circ - 65^\circ - 65^\circ = 50^\circ$. ($\angle$ sum of a straight line)</p> <p>ANS: (a) 245° (b) 50°</p>
Q11	<p>$\angle EFH = (180^\circ - 90^\circ) \div 2 = 45^\circ$. ($\triangle EFH$ an isosceles right triangle) $\angle FEJ = 180^\circ - 45^\circ - 106^\circ = 29^\circ$. ($\angle$ sum of Triangle EFK) $\angle EFJ = \angle EKF = (180^\circ - 29^\circ) \div 2 = 75.5^\circ$. ($\triangle EFJ$ an isosceles triangle) $\therefore \angle KFJ = \angle EFJ - \angle EFK = 75.5^\circ - 45^\circ = 30.5^\circ$.</p> <p>ANS: 30.5°</p>
Q12	<p>Total remains after the pink balloons burst = $66 - 17 = 49$. The number of blue balloons increased by 75% $\rightarrow 79 - 49 = 30$. The number of blue balloons at first = $30 \div 75\% = 40$. \therefore The number of pink balloons at first = $66 - 40 = 26$.</p> <p>ANS: 26</p>
Q13	<p>(a) Volume of water drained from the tank = $4 \times 6 = 24$ l.</p> <p>(b) Volume of water left in the tank = $3500 \times 80 \times \frac{1}{4} \div 1000 - 24 = 70 - 24 = 46$ l, Capacity of the tank = $3500 \times 80 \div 1000 = 280$ l. \therefore Height of Tank Y = $280 - 46 = 234$ l.</p> <p>ANS: (a) 24 l (b) 234 l</p>
Q14	<p>(a) Assume the length and breadth of the rectangular box are L and B cm respectively. Then, $3L + 42 = L + 4B + 10$, $\rightarrow 2L + 32 = 4B \rightarrow L + 16 = 2B$, \therefore The width at the side = $2B - L = 16$ cm.</p> <p>(b) $2B = 0.9 \text{ m} = 90 \text{ cm}$, $\rightarrow L = 2B - 16 = 90 - 16 = 74 \text{ cm}$. Height of the cupboard = $3 \times 74 + 42 = 264 \text{ cm} = 2.64 \text{ m}$.</p> <p>ANS: (a) 16 cm (b) 2.64 m</p>

Q15	<p>(a) Remaining $1 - \frac{1}{8} = \frac{7}{8}$ of the clip were red, blue and yellow. Since $\frac{2}{7}$ of the remaining clips $= \frac{2}{7} \times \frac{7}{8} = \frac{2}{8}$ were red, thus, $1 - \frac{1}{8} - \frac{2}{8} = \frac{5}{8} \rightarrow 2 \times 35 = 70$ were blue and yellow clips. Hence, $\frac{2}{8} \rightarrow 70 \div 5 \times 2 = 28$ were red clips.</p> <p>(b) $35 \div 6 = 5$ R 5 and the remaining 5 blue clips can be put in 1 box of 3 clips and the other box of 2 clips. Thus a total of $5 + 1 + 1 = 7$ boxes is needed,</p> <p style="text-align: right;">ANS : (a) 28 (b) 7</p>												
Q16	<p>(a) Area of the figure $= 0.5 \times 3.14 \times 10^2 + 20 \times 5 - 3.14 \times 5^2 = 178.5 \text{ cm}^2$.</p> <p>(b) Perimeter of the figure $= 2 \times 3.14 \times 5 + \frac{1}{2} \times (2 \times 3.14 \times 10) + 5 + 5 = 72.8 \text{ cm}$.</p> <p style="text-align: right;">ANS: (a) 178.5 cm^2 (b) 72.8 cm</p>												
Q17	<p>Assume Kathy had \$u at the end, then the amount of money they had at the end and at first can be summarized in the table,</p> <table style="margin-left: auto; margin-right: auto;"> <thead> <tr> <th></th> <th style="text-align: center;"><u>Kathy</u></th> <th style="text-align: center;"><u>Alice</u></th> </tr> </thead> <tbody> <tr> <td>At the end</td> <td style="text-align: center;">u</td> <td style="text-align: center;">2u</td> </tr> <tr> <td>At first</td> <td style="text-align: center;">u + 300</td> <td style="text-align: center;">2u - 50</td> </tr> <tr> <td></td> <td style="text-align: center;">3P</td> <td style="text-align: center;">4P</td> </tr> </tbody> </table> <p>(a) Now, $3P = u + 300$ and $4P = 2u - 50$. $4(3P) = 3(4P) = 12P$, $4(u + 300) = 3(2u - 50)$, $4u + 1200 = 6u - 150$, $1200 + 150 = 6u - 4u$, $2u = 1350$, $u = 675$. $\therefore 2u - 50 = 2 \times 675 - 50 = 1300$. Alice had \$1300 at first.</p> <p>(b) Kathy had \$675 at the end.</p> <p style="text-align: right;">ANS : (a) \$1300 (b) \$675</p>		<u>Kathy</u>	<u>Alice</u>	At the end	u	2u	At first	u + 300	2u - 50		3P	4P
	<u>Kathy</u>	<u>Alice</u>											
At the end	u	2u											
At first	u + 300	2u - 50											
	3P	4P											