

RED SWASTIKA SCHOOL
 MATHEMATICS
 PRIMARY 6
 CLASS TEST (1)

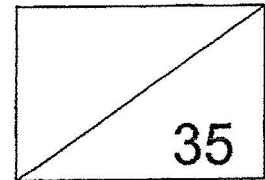

Name: _____ ()

Date: 25 February 2025

Class: Pr 6 _____

Duration: 45 minutes
 (Use of calculators is not allowed)

Parent's Signature: _____

Questions 1 to 2 carry 1 marks each. Question 3 to 5 carry 2 marks each. For each question, four options are given. One of them is the correct answer. Make your choice (1, 2, 3 or 4). Write the correct answer in the brackets provided. (8 marks)

1 What fraction of the hearts are shaded?

- (1) $\frac{7}{12}$
- (2) $\frac{5}{12}$
- (3) $\frac{5}{7}$
- (4) $\frac{1}{2}$

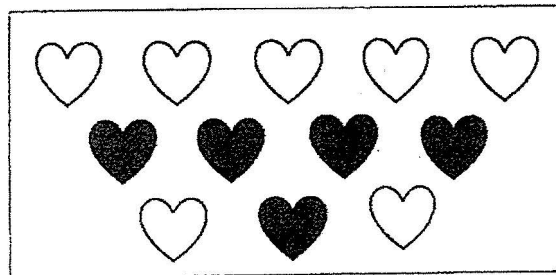

()

2 PQ and RS are straight lines. Which of the following is true?

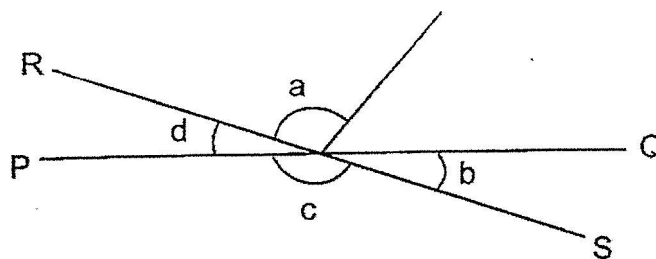

- (1) $\angle a + \angle c = 180^\circ$
- (2) $\angle a + \angle d = 180^\circ$
- (3) $\angle a = \angle c$
- (4) $\angle b = \angle d$

()

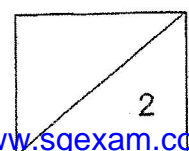

- 3 In the number line, which of the following fractions is between A and 0.3?

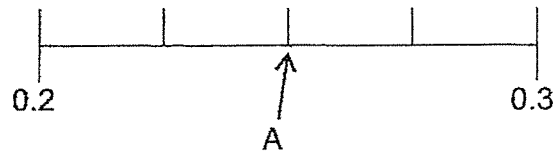

- (1) $\frac{2}{9}$
(2) $\frac{2}{7}$
(3) $\frac{2}{5}$
(4) $\frac{3}{4}$
- 4 In a party of 72 children, there was an equal number of boys and girls. $\frac{1}{4}$ of the boys did not wear spectacles and $\frac{2}{3}$ of the girls did not wear spectacles. The remaining children wore spectacles.

How many children at the party wore spectacles?

- (1) 6
(2) 33
(3) 39
(4) 66

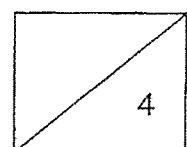

5 In the figure below, ABCD is a rectangle and $AB = AE$. Find $\angle BEC$.

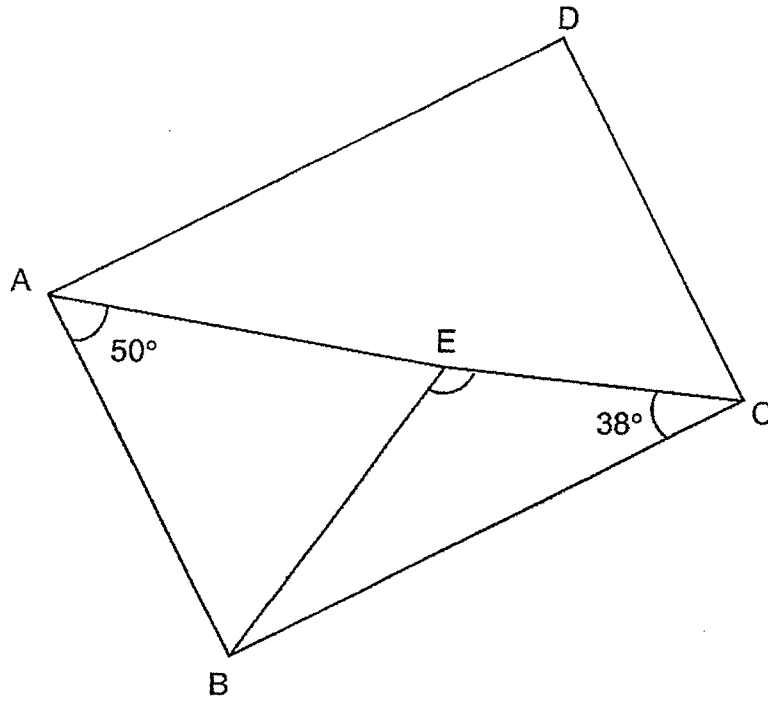

- (1) 104°
- (2) 115°
- (3) 117°
- (4) 132°

()

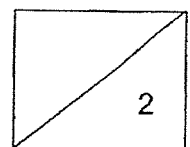

Questions 6 to 13 carry 2 marks each. Show your workings clearly in the space below each question and write your answers in the spaces provided. For questions which require units, give your answers in the units stated. (16 marks)

6 (a) Find the value of $\frac{5}{6} - \frac{1}{4}$

Ans: (a) _____

(b) Find the value of $\frac{3}{5} \div 15$

Give your answer as a fraction in the simplest form.

Ans: (b) _____

7 In the figure below, ABC is a triangle.

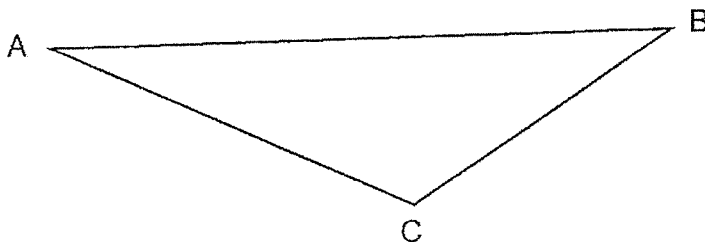

(a) Name ONE acute angle in the triangle.

Ans: (a) \angle _____

(b) Use a protractor to measure the largest angle in the triangle. Write the answer in the answer space provided.

Ans: (b) _____

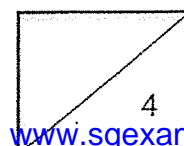

8 Find $\angle m$ in the figure shown.

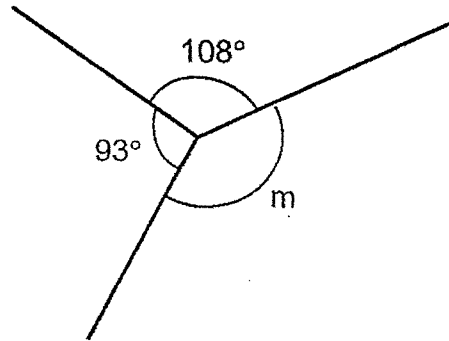

Ans: _____

9 The figure is made up of identical triangles. Four of them are shaded. Shade two more triangles so that PQ is the line of symmetry for the figure.

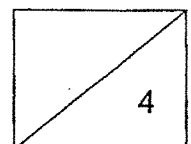
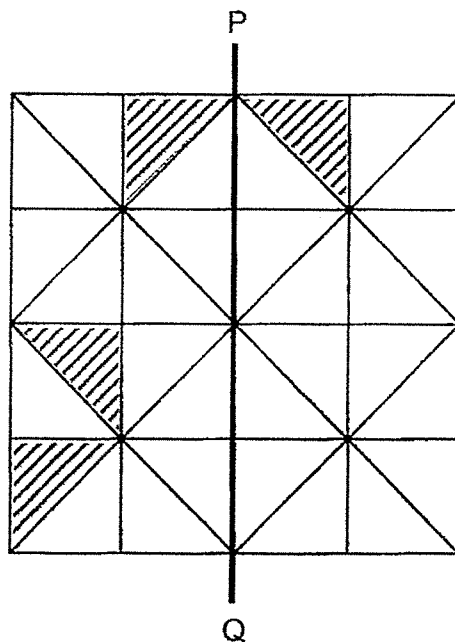

10 Lina had 20 kg of flour. She packed the flour into boxes.

Each box contained $\frac{3}{5}$ kg of flour.

(a) At most, how many boxes of flour could she have packed?

Ans: (a) _____

(b) How much flour would be left unpacked?

Give your answer in kg.

Ans: (b) _____ kg

11 A box contained red, blue, yellow and orange beads. There was an equal number

of yellow and orange beads. $\frac{1}{3}$ of the beads were red. $\frac{2}{7}$ of the remainder were

blue. What fraction of the beads in the box were yellow?

Ans: _____



- 12 In the figure, a parallelogram piece of paper is folded as shown and $WX = WY$. Find $\angle n$.

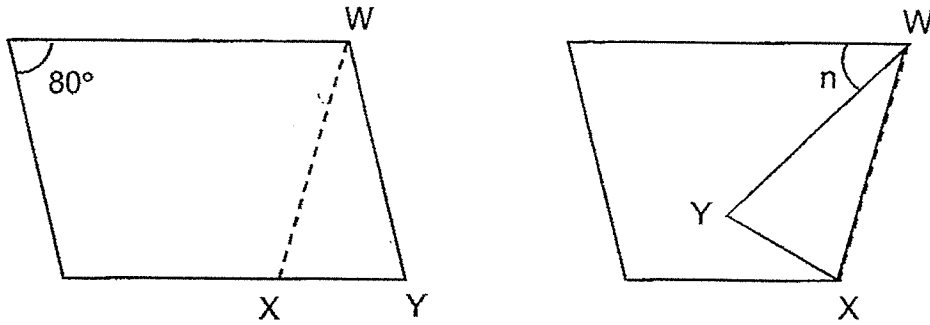

Ans: _____

- 13 A parallelogram P is drawn on the square grid below with 4 straight lines.
- (a) Draw an isosceles triangle with the same area as P. Label the triangle as T1.
- (b) Draw a trapezium with the same perimeter as P. Label the trapezium as T2.

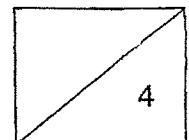
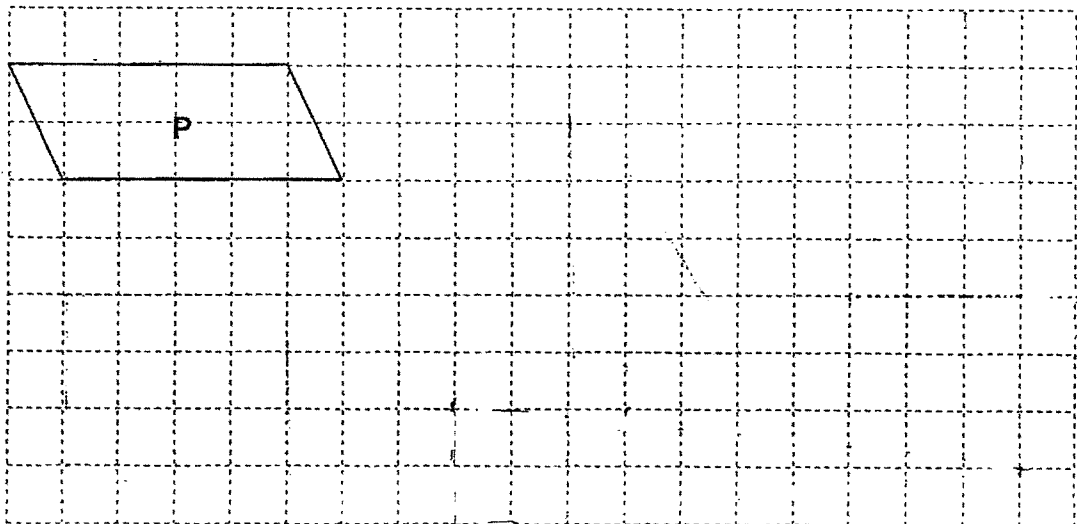

For Questions 14 to 16, show your workings clearly in the space below each question and write your answers in the spaces provided. The number of marks available is shown in brackets [] at the end of each question or part-question. (11 marks)

14 Mr Thomas had some red and green apples for sale. He sold 270 red apples.
 $\frac{1}{4}$ of the total number of apples sold were green.

(a) How many red and green apples did Mr Thomas sell altogether?

Ans: (a) _____ [1]

(b) He sold $\frac{2}{5}$ of his apples. He had 85 unsold green apples.
How many red apples were unsold?

Ans: (b) _____ [3]

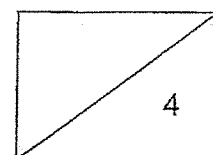

- 15 In the figure, ABCD is a rhombus, ACFE is a quadrilateral and $AE \parallel HF$.

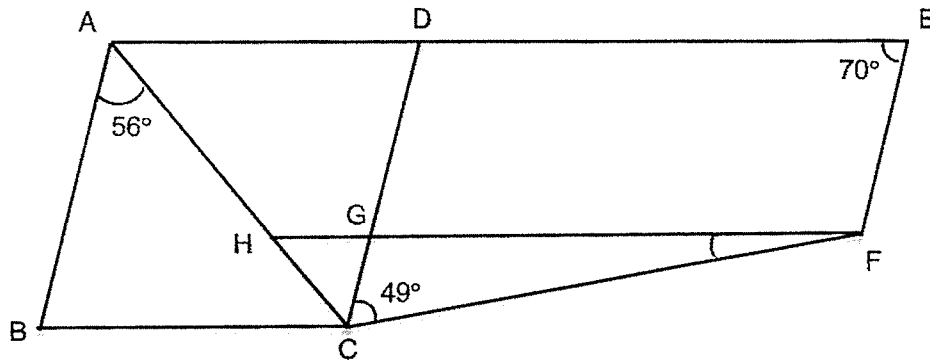

- (a) Find $\angle CFG$.

Ans: (a) _____ [2]

- (b) Circle the words that describe DEFG in the statement. [1]

Since DE (is / is not) parallel to GF and DG (is / is not) parallel to EF,
DEFG is a (parallelogram/trapezium).

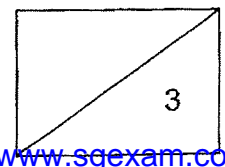

16 A shop had a number of iPads for sale. The shop sold 32 iPads in the morning and $\frac{5}{6}$ of the remainder in the afternoon. After selling another 20 iPads in the night, it was left with $\frac{1}{8}$ of the iPads.

(a) How many iPads were left?

Ans: _____ [2]

(b) How many iPads were sold in the afternoon?

Ans: _____ [2]

End of Paper

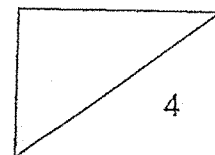

YEAR : 2025
 LEVEL : PRIMARY 6
 SCHOOL : RED SWASTIKA SCHOOL
 SUBJECT : MATHEMATICS
 TERM : CLASS TEST 1

(BOOKLET A)

Q1	2	Q2	4	Q3	2	Q4	3	Q5	3
----	---	----	---	----	---	----	---	----	---

(BOOKLET B)

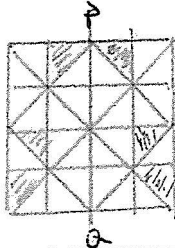
Q6	a)	$\frac{1}{4} = \frac{6}{24}$ $\frac{5}{6} = \frac{20}{24}$ $\frac{20}{24} = \frac{6}{24} = \frac{14}{24}$ $= \frac{7}{12}$				
	b)	$\frac{3}{5} \div 15 = \frac{3}{90} = \frac{1}{30}$				
Q7	a)	Angle ABC				
	b)	123°				
Q8	360° - 108° + 93° = 159°					
Q9						
Q10	a)	$20 \div \frac{3}{5} = 33\frac{1}{3}$ <p>Ans : 33</p>				
	b)	$\frac{1}{3} \times \frac{3}{5} = \frac{1}{5}$				
Q11	<p>Red = 7u Blue = 4u Yellow + Orange = 10u Blue + Yellow + Orange = 14u Total = 14 + 7 = 21 Yellow = 5u $= \frac{21}{5}$</p>	<p>(Red) (B + Y + O)</p> <table style="margin-left: auto; margin-right: auto;"> <tr> <td style="border: 1px solid black; padding: 2px;">7u</td> <td style="border: 1px solid black; padding: 2px;">14u</td> </tr> <tr> <td style="border: 1px solid black; padding: 2px;">4u</td> <td style="border: 1px solid black; padding: 2px;">10u</td> </tr> </table> <p style="margin-left: 20px;"> Blu Y O v v 5 5 0 </p>	7u	14u	4u	10u
7u	14u					
4u	10u					
Q12	100° - 20° + 20° = 60°					

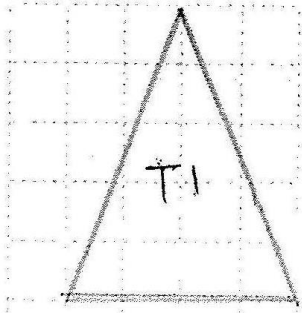
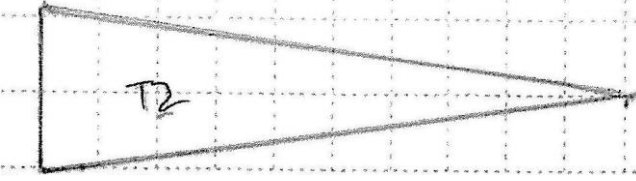
Q13	
Q14	
Q14 (a)	$\frac{3}{4} = 270$ $\frac{1}{4} = 90$ $\frac{4}{4} = 90 + 270 = 360$
Q14 (b)	$\frac{2}{5} = 360$ $\frac{1}{5} = 180$ $\frac{3}{5} = 540$ $540 - 85 = 455$
Q15 (a)	$180^\circ - 56^\circ - 56^\circ = 68^\circ$ $\text{Angle CFG} = 180^\circ - 56^\circ - 56^\circ - 49^\circ = 19^\circ$
Q15 (b)	<p>Since DE is parallel to GF and DG is not parallel to EF, DEFG is a trapezium.</p>
Q16 (a)	$\frac{1}{6} = 20 + \frac{1}{8}P$ $\frac{5}{6} = 100 + \frac{5}{8}P$ $\frac{2}{8} = 32 + 100 + 20 = 152$ $152 \div 2 = 76$
Q16 (b)	$\frac{5}{8} = 76 \times 5 = 380$ $380 + 100 = 480$