



NANYANG PRIMARY SCHOOL
2025
~~2024~~

PRIMARY 6
MID-YEAR PRACTICE PAPER

SCIENCE
(BOOKLET A)

Total Time for Booklets A and B: 1 h 45 min

INSTRUCTIONS TO CANDIDATES

1. Write your name and index number in the space provided.
2. Do not open this booklet until you are told to do so.
3. Follow all instructions carefully.
4. Answer all questions.
5. For each question from 1 to 28, four options are given.
Indicate your choice in this booklet.
Shade the correct oval (1, 2, 3 or 4) on the Optical Answer Sheet provided.

Name: _____ ()

Class: Primary 6 ()

Booklet A consists of 18 printed pages including this cover page.

Section A: Multiple Choice Questions [56 marks]

1. Which of the following statements are true?

- A All living things depend directly on plants for food.
- B The Sun is the main source of energy for all living things.
- C Energy is transferred from the Sun to plants during photosynthesis.
- D Only water, oxygen and sunlight are needed for a plant to make food.

- (1) A and C only
- (2) A and D only
- (3) B and C only
- (4) B and D only

2. Minah wanted to find out how a plant affects the amounts of gases in its surroundings at different times of a day. She placed the set-ups in a well-lit garden as shown below.

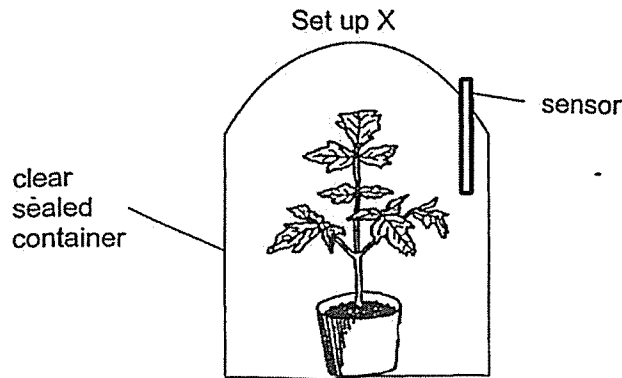

She measured the amount of two different gases in the container, Gas C and Gas D as shown in the graph below.

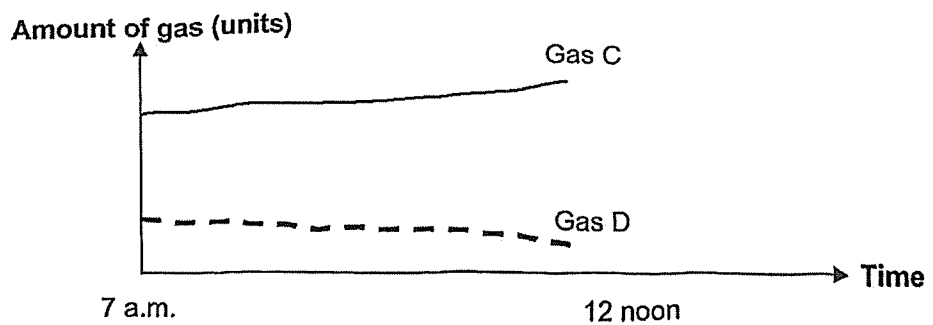

Which one of the following would most likely be correct?

	Gas C	Gas D
(1)	carbon dioxide	oxygen
(2)	oxygen	carbon dioxide
(3)	nitrogen	oxygen
(4)	carbon dioxide	nitrogen

3. Alani conducted an experiment in a dark room to find out how the amount of light affects the rate of photosynthesis. He used a device to count the number of bubbles produced by the water plant in three minutes.

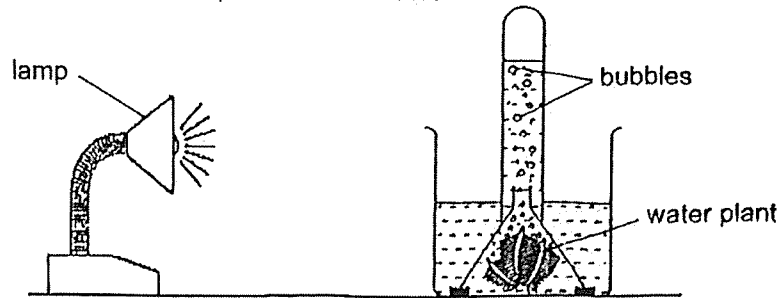

Then he added a sheet of paper between the lamp and the water plant and counted the number of bubbles produced. He repeated this step until a total of 6 sheets of paper were used.

Which of the following graphs correctly shows his most likely observations?

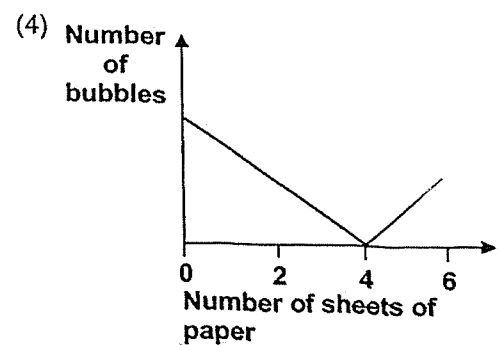
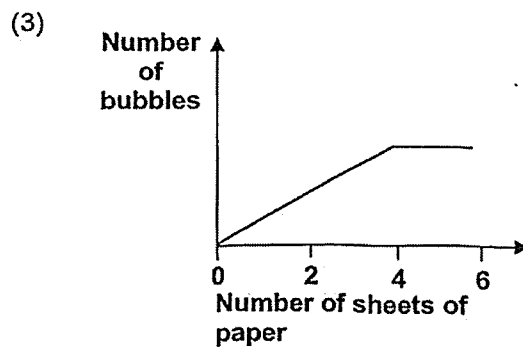
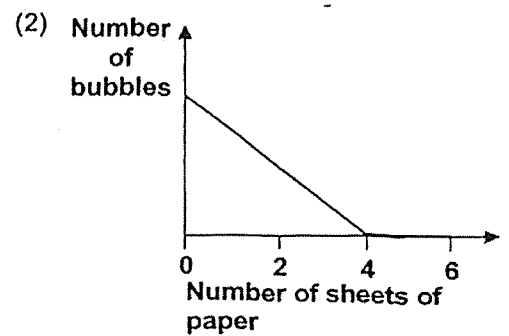
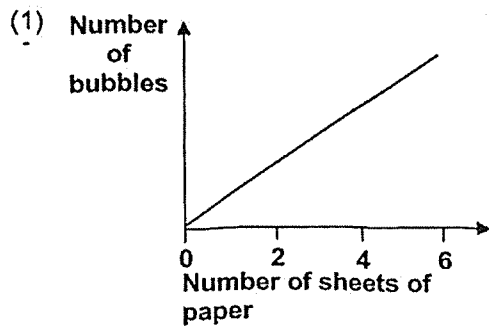

4. The diagram below shows a habitat.

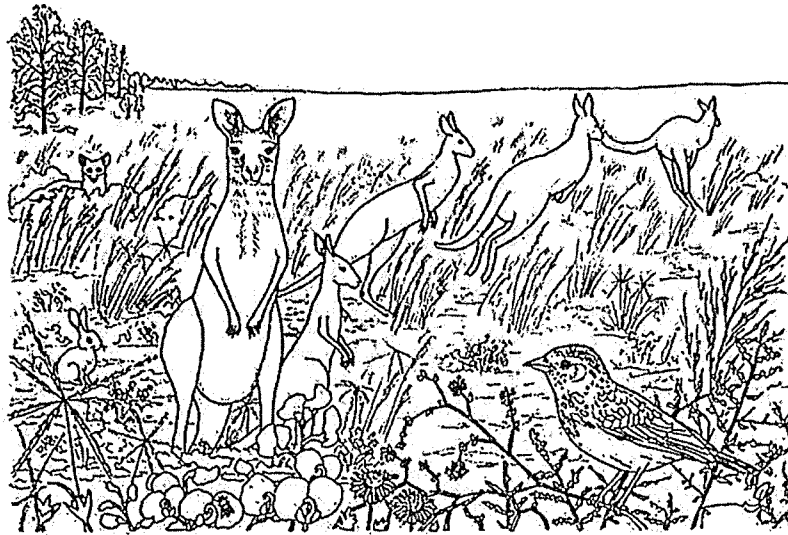

Based on the diagram above, which one of the following statements is correct?

- (1) There are only 8 organisms in this habitat.
 - (2) The rabbit and the bird form two communities.
 - (3) There is at least 2 populations of animals in this habitat.
 - (4) There are different populations of plants and animals in the habitat.
5. The diagram below shows a pond and the organisms living in it. The organisms depend on each other for survival.

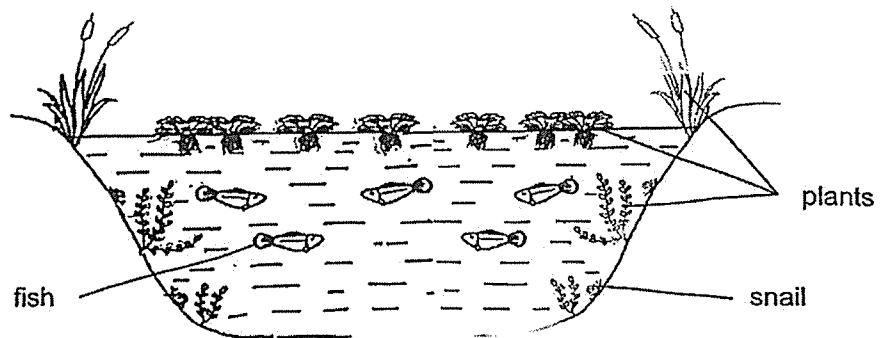

Which one of the following statements correctly describes how the organisms benefit from each other?

- (1) Fish provide oxygen for the plants and plants provide food for the fish.
- (2) Snails provide oxygen for the plants and plants provide shelter for the snails.
- (3) Fish provide carbon dioxide for the plants and plants provide food for the fish.
- (4) Snails provide carbon dioxide for the plants and plants provide droppings for the snails.

6. The graph below shows how the number of fishes in a pond community changed over a period of six months. The fishes in the pond feed on the water plants.

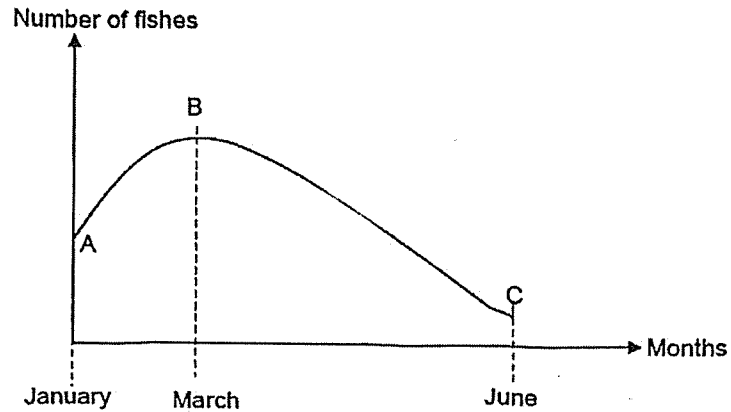

What are the likely reasons for the change in the number of fishes in the pond?

- W From A to B, the birth rate of fishes was equal to its death rate.
- X From A to B, the number of animals feeding on the fishes increased.
- Y From B to C, water plants were removed from the pond.
- Z From B to C, several organism X were added and they competed for food with the fishes.

- (1) W and X only
- (2) W and Y only
- (3) X and Z only
- (4) Y and Z only

7. Hugo found the following organisms in a forest.



ant



earthworm



fungi



fern

Which of the above organism(s) is/are decomposer(s)?

- (1) fungi only
- (2) fungi and fern only
- (3) ant and earthworm only
- (4) earthworm and fern only

8. Study the food web below.

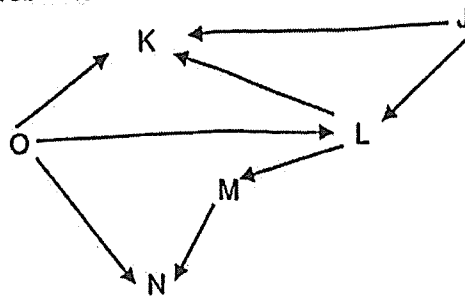

Which of the following about living things J to O in the food web above is correct?

	Producer only	Predator only	Predator and Prey
(1)	O and J	K and N	L and M
(2)	J and K	N	M and O
(3)	J	K and N	M and O
(4)	L	K	J and N

9. The food chain below shows the food relationship between four organisms in a community.

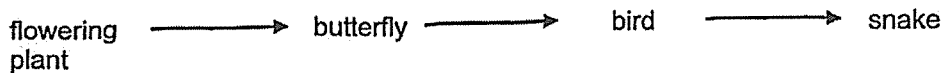

Based on the food chain above, which one of following graphs shows the change in population of flowering plant and snake after the number of birds increased in the community?

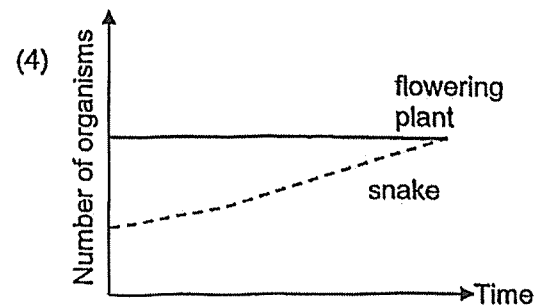
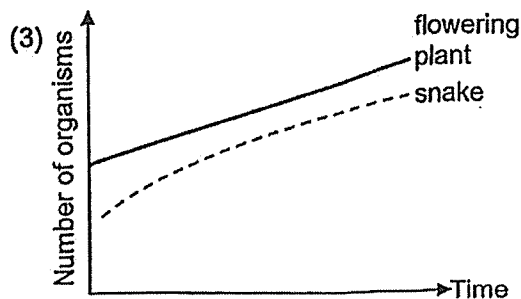
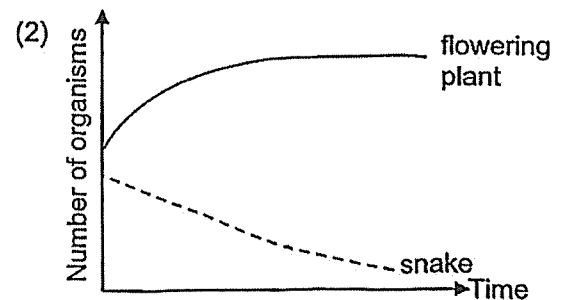
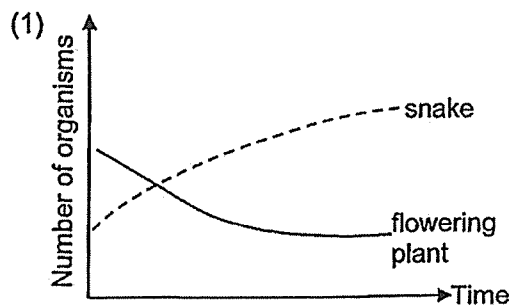

10. Amin observed the relationships between five types of organisms, P, Q, R, S and T, from the same community. He classified four of the types of organisms in the table below.

Predator only	Prey only	Predator and prey
T	Q and S	R

Which one of the following food webs would most likely represent the relationships between the organisms in the community?

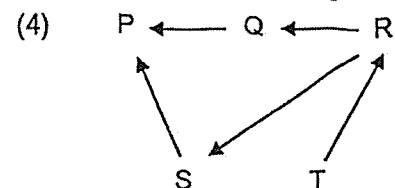
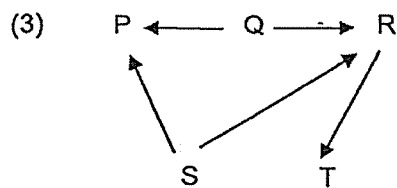
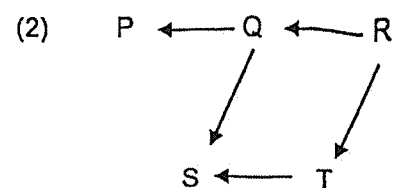
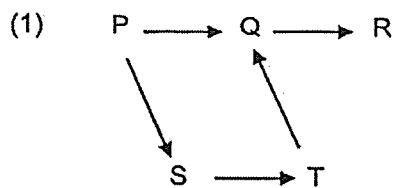

11. The table below shows the state of three substances X, Y and Z at different temperatures.

Substance	State of Substance		
	20°C	40°C	60°C
X	liquid	liquid	gas
Y	solid	solid	liquid
Z	solid	solid	solid

Based on the information above, which of the following statements are correct?

- A Substance X has the lowest boiling point.
- B Substance Y has the highest melting point.
- C Substance X has a lower freezing point than substance Z.

- (1) A and B only
- (2) A and C only
- (3) B and C only
- (4) A, B and C

12. Jessica left a beaker of ice on the table for 1 hour. After which, 50ml of boiling water was added into the beaker and it was left on the table for 3 hours.

She recorded the changes in its temperature as shown in the graph below.

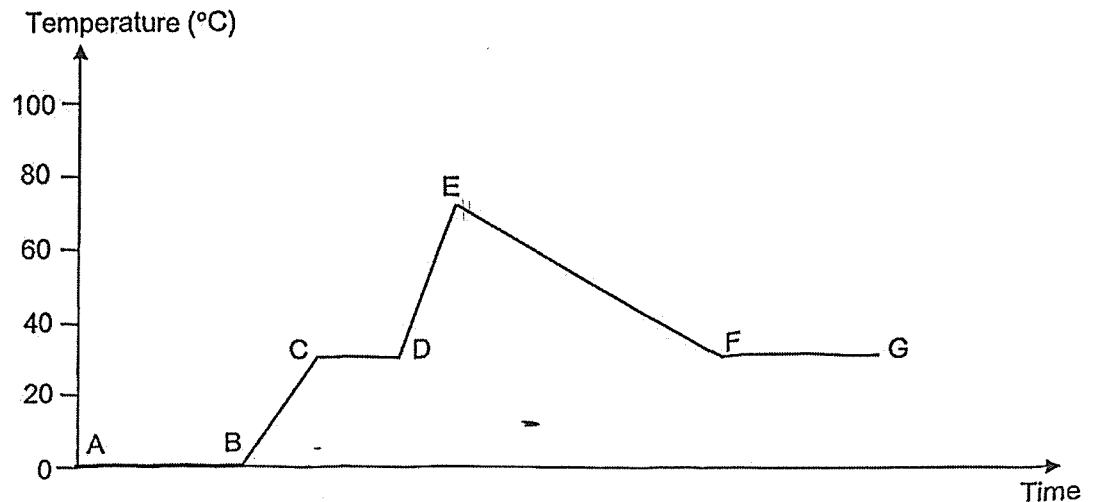

Which part(s) of the graph show(s) ice/water increasing in temperature?

- (1) BC and DE only
 - (2) AB, CD and EF only
 - (3) AB, BC, CD and DE only
 - (4) AB, BC, CD, DE and FG only
13. The diagram below shows the fruit of plant A.

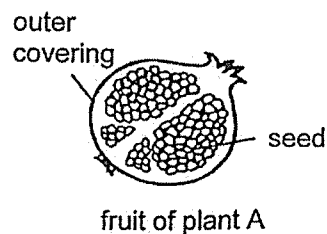



Which of the following statements about the flower that fruit of plant A came from are correct?

- P The flower has many ovaries.
 - Q The ovary of the flower contains many ovules.
 - R The seeds are formed when male reproductive cells fuse with the ovary.
 - S The flower undergoes pollination and fertilisation before fruit A developed.
- (1) P and Q only
 - (2) P and R only
 - (3) Q and S only
 - (4) R and S only

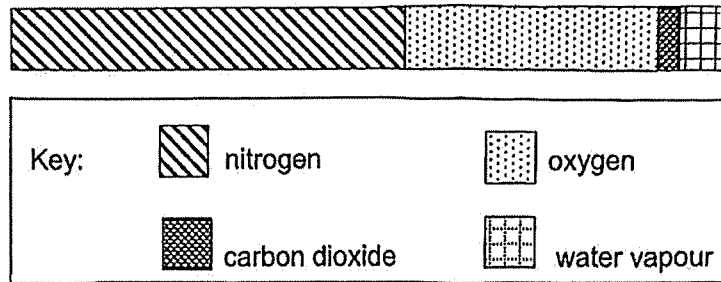
16. Three people were trapped in the lift where no air can enter and leave. The diagram below shows the composition of four different gases in the lift at the start.

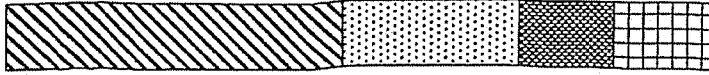
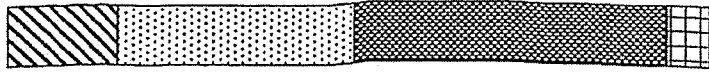

Which of the following correctly shows the composition of gases in the lift after 1 hour?

- (1) 
- (2) 
- (3) 
- (4) 

17. The diagram below shows the human digestive system.

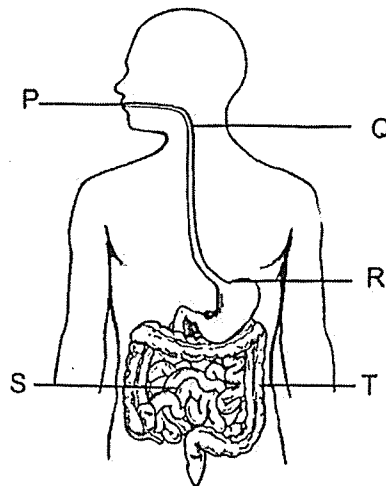

Which of the following correctly identifies the parts where digestion of food takes place? -

- (1) P, Q and S only
- (2) P, R and S only
- (3) P, R and T only
- (4) R, S and T only

18. Lindsey wanted to classify the four plants shown below.

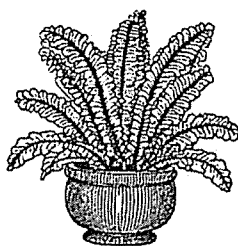

fern

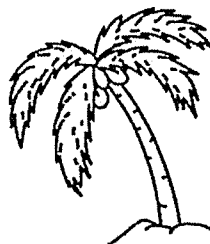

coconut tree



orchid plant

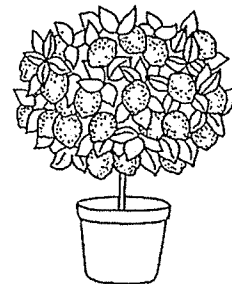

lime plant

Which one of the following questions can be used to classify the plants above into two groups?

- (1) Can it make its own food?
- (2) Does it reproduce by seeds?
- (3) Does it need air, food and water?
- (4) Can it respond to changes in its surroundings?

19. Which one of the following does not involve energy conversion?

- (1) Capturing light in solar panels.
- (2) Turning on the classroom light.
- (3) Leaving a cup of ice cubes to melt.
- (4) Using a pen to write on a piece of paper.

20. Mdm Leong used an electric toaster to toast some bread as shown in the diagram below. When the bread was toasted, she observed hot mist rising from the bread and she heard a sound from the toaster.

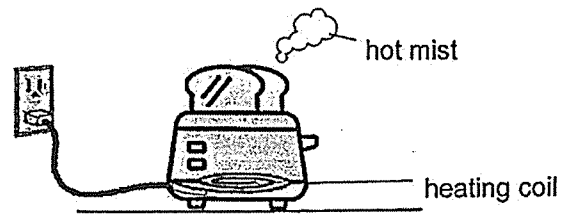

Which of the following shows the correct energy changes that took place at different parts of the set-up?

	Electrical wire	Heating coil	Mist rising	Toaster sound
(1)	heat energy	→ electrical energy	→ potential energy	→ sound energy
(2)	heat energy	→ electrical energy	→ kinetic energy	→ potential energy
(3)	electrical energy	→ heat energy	→ potential energy	→ potential energy
(4)	electrical energy	→ heat energy	→ kinetic energy	→ sound energy

21. June set up an experiment to find out how the number of turns of a toy affects the distance moved by the cube as shown below.

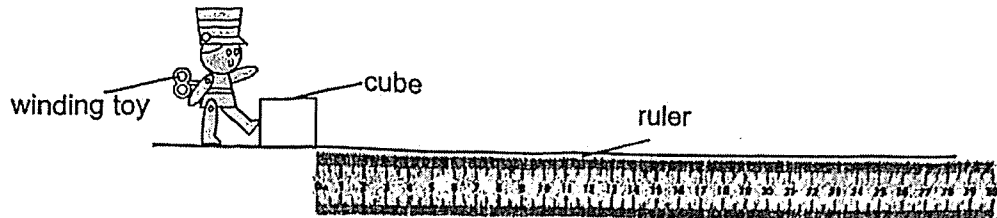

The distance moved by the cube was measured and recorded in the table shown below.

Number of times the toy was wound	Distance moved by the cube (cm)
0	0
1	4
3	12
5	23

Based on the aim and results of the experiment above, which one of the following conclusions is correct?

- (1) The distance moved by the cube will increase if a cube of bigger mass is used.
- (2) As the number of times of the toy increases, the distance moved by the toy increases.
- (3) The distance moved by the cube will decrease when the number of times the toy was wound increases.
- (4) The chemical potential energy of the toy is converted into kinetic energy of the cube when the toy kicks the cube.

22. The diagram below shows a ball rolling down a slide until it stopped at Z.

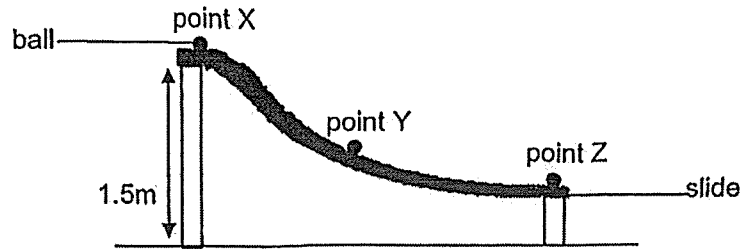

Which of the following describes the energy possessed by the ball at the different positions?

- A From X to Y, kinetic energy of the ball increased.
- B The ball had less kinetic energy at Z than at Y.
- C From Y to Z, potential energy of the ball decreased.
- D The moving ball possessed no potential energy at Y.

- | | |
|---------------------|---------------------|
| (1) A and C only | (2) B and D only |
| (3) A, B and C only | (4) B, C and D only |

23. The diagram below shows Alan throwing a basketball towards the basketball hoop.

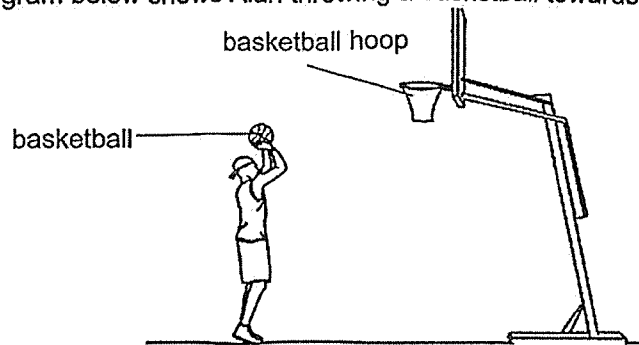

Which of the following describes the effect of the force Alan exerted at the start?

- (1) The force changed the shape of the ball.
- (2) The force caused the ball to start moving.
- (3) The force caused the ball to stop moving.
- (4) The force decreased the speed of the ball.

24. When constructing buildings, concrete blocks must be pushed into the ground by heavy weights as shown in the diagram below.

The weight is lifted by a machine and then released to hit the concrete block.

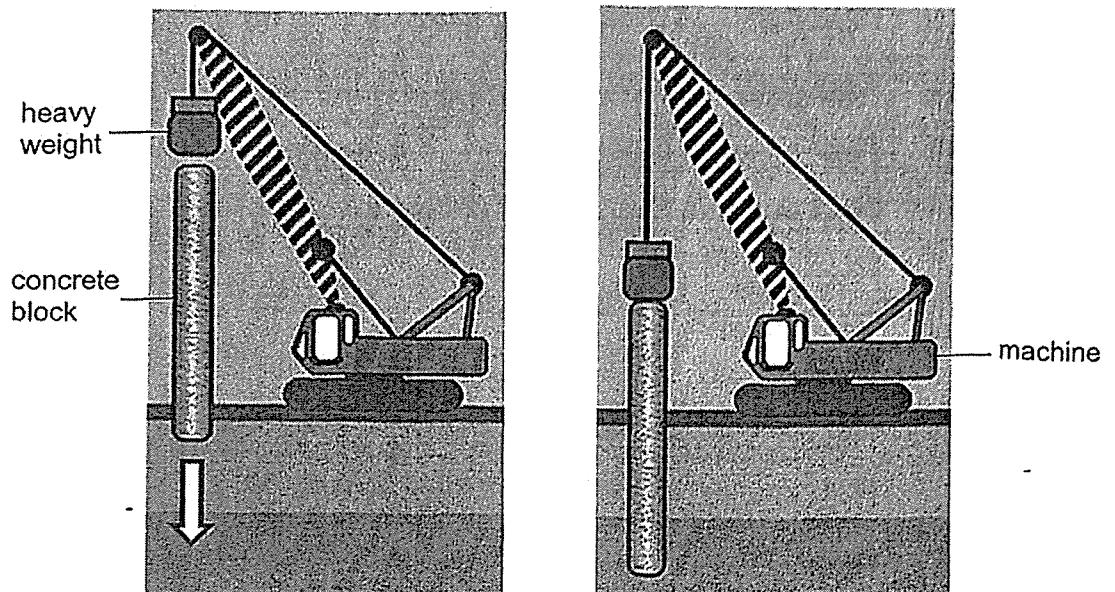

Which of the following would enable the weight to push the block deeper into the ground?

- A Use a weight of greater mass.
- B Apply oil on the bottom of the weight.
- C Raise the weight to a greater height before release.
- D Move the weight closer to the concrete block before release.

- (1) A and C only
- (3) B and C only

- (2) A and D only
- (4) B and D only

25. Pete was looking at a painting which was hung behind a wall through a hole as shown in the diagram below.

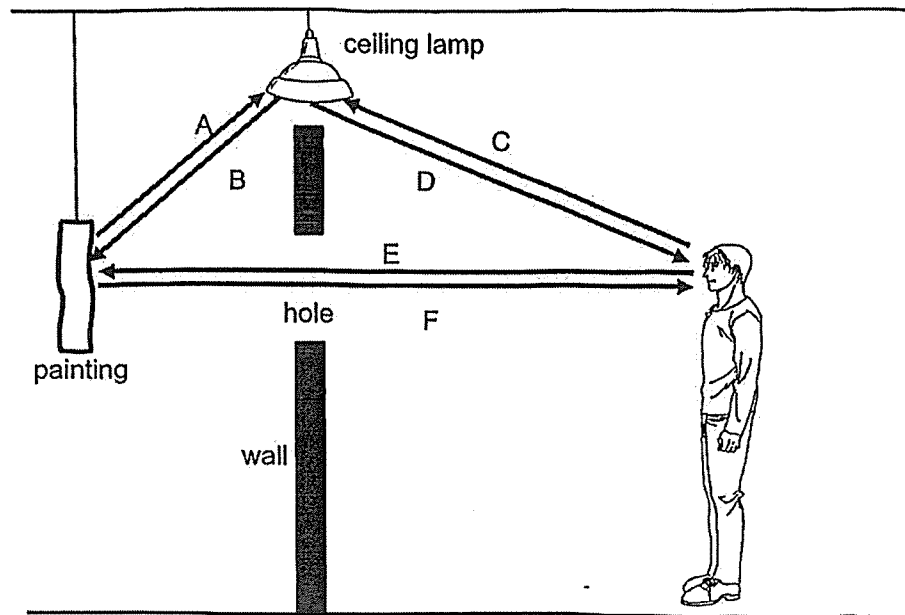

Which of the arrows show the correct direction of light rays that enabled Peter to see the painting?

- | | |
|---------------------|---------------------|
| (1) A and E only | (2) B and F only |
| (3) A, C and E only | (4) B, D and F only |

26. Brandon cut out some shapes from a piece of cardboard as shown below. The shapes had the same height and width.

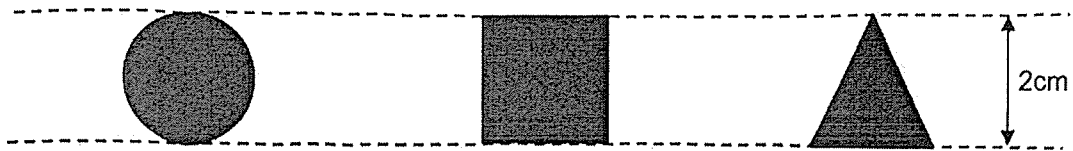

He then hung the shapes in a straight line at positions D, E and F as shown in the diagram below.

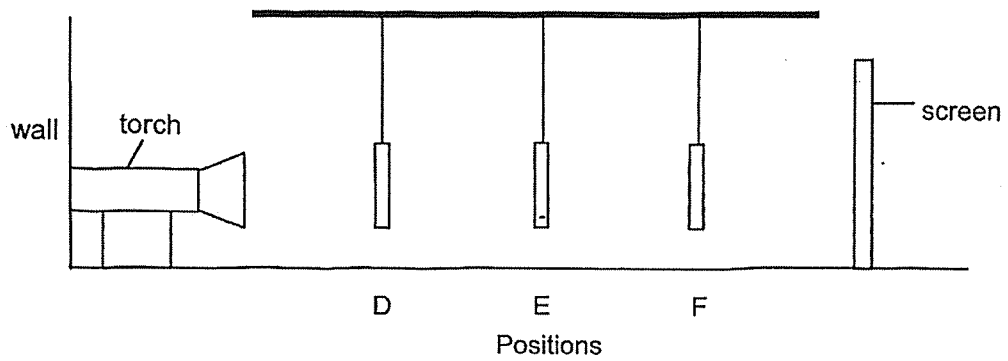

The following shadow was cast on the screen.

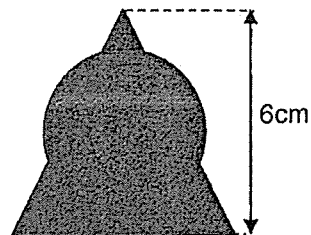

Based on the shadow formed, which of the following shows the correct positions of the shapes in the set-up above?

	Position D	Position E	Position F
(1)			
(2)			
(3)			
(4)			

27. Different volumes of hot water at 80°C were poured into four identical containers. Which one of the following containers will contain the lowest amount of heat?

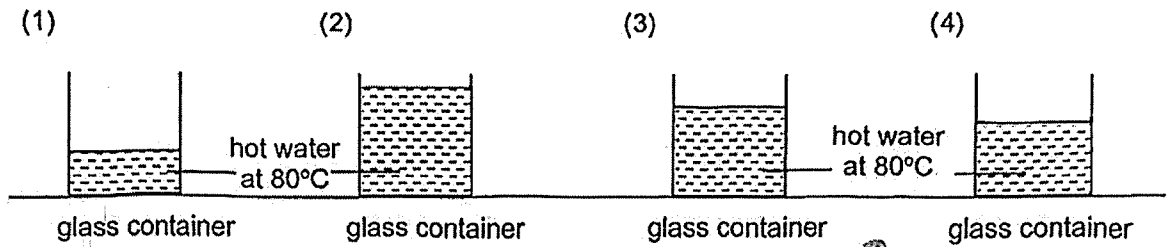

28. When railway tracks are built, gaps are left between them to allow for expansion of the tracks so that they would not be damaged. Each section of the railway track, part X, is of the same length.

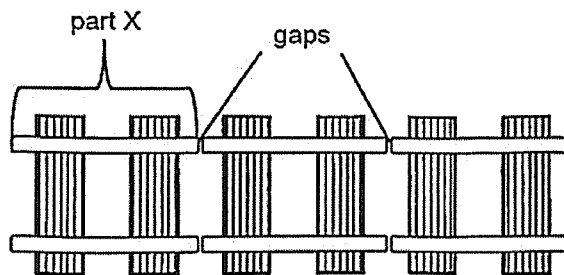

Top view of railway track

There should be a wide enough gap between one part X and another part X.

Which one of the following information would be most useful to a person building the railway tracks?

- (1) Shortest length of part X on the hottest day
- (2) Shortest length of part X on the coldest day
- (3) Greatest length of part X on the hottest day
- (4) Greatest length of part X on the coldest day

~ END OF BOOKLET A ~



NANYANG PRIMARY SCHOOL

2023
PRIMARY 6
MID-YEAR PRACTICE PAPER

SCIENCE
(BOOKLET B)

Total Time for Booklets A and B: 1 h 45 min

INSTRUCTIONS TO CANDIDATES

1. Write your name and index number in the space provided.
2. Do not open this booklet until you are told to do so.
3. Follow all instructions carefully.
4. Answer all questions.
5. Write your answers to Questions 29 to 40 in the spaces provided.

Booklet A:		56
Booklet B:		44
Total:		100

Name: _____ ()

Class: Primary 6 ()

Parent's signature: _____

Booklet B consists of 14 printed pages including this cover page.

Section B: Open-Ended Questions [44 marks]

29. The diagram below shows organism P. The young of organism P feeds on leaves.

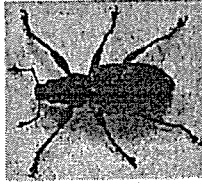

Alina conducted an experiment to find out the effects of the surrounding temperature and the amount of water vapour in the air on the number of eggs hatched by organism P over a period of time.

The graphs below show the results of her experiment.

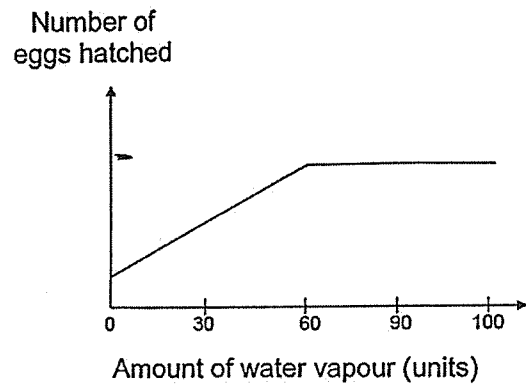
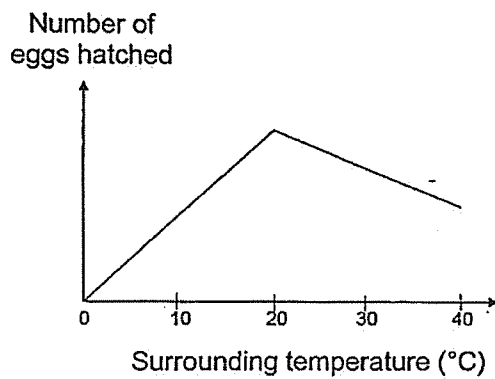

(a) Based on the results above, suggest the conditions needed for Alina to ensure the most number of eggs hatched over a period of time. Give a reason for your answer. [2]

Organism P lays its eggs, which hatch into larvae, on the leaves of plants. The larvae grow in size after some time.

(b) Explain how laying its eggs on leaves increases the chances of survival of organism P's young. [1]

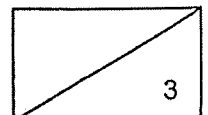

30. The diagram below shows the food relationships among the different organisms in a tank.

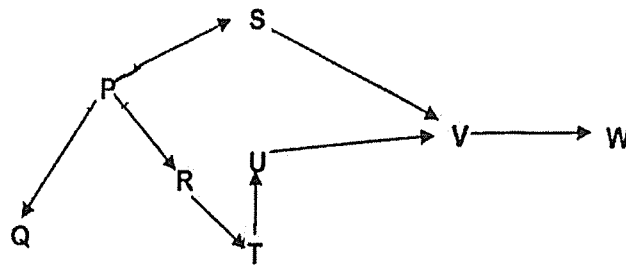

(a) Identify the food producer from the table above. [1]

(b) (i) State the organism(s) that would be directly affected when the population of T decreased significantly. [1]

(ii) Explain how the organism(s) in (i) would be affected. [2]

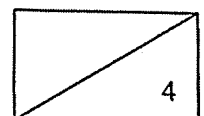

31. Jeyna took a box of frozen meat out from the freezer. Soon, she observed a thin layer of ice forming on the package as shown in the diagram below.

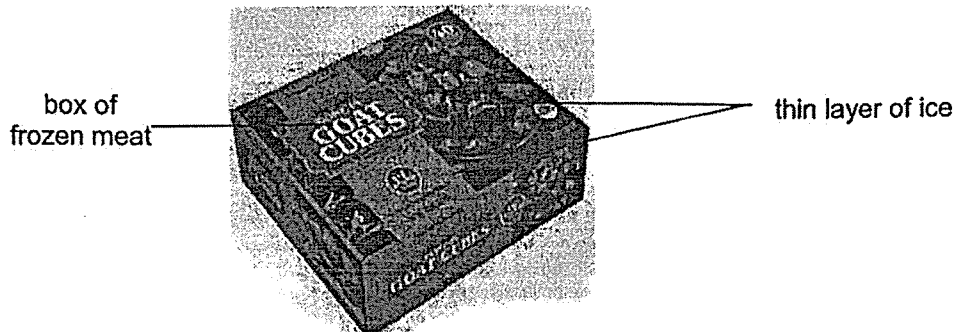

- (a) Explain how a thin layer of ice had formed on the packaging of the box after it was taken out from the freezer. [2]

- (b) After a short while, Jeyna noticed that the thin layer of ice had disappeared. Explain what had happened. [1]

32. Darren had two fruits, P and Q, as shown below.

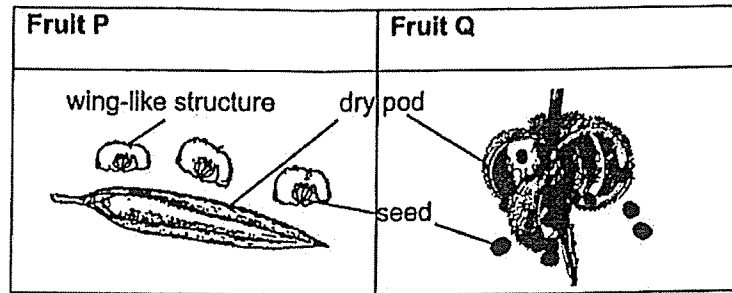

- (a) State the dispersal method of Fruit P and Fruit Q. [1]
- (i) Fruit P: _____
- (ii) Fruit Q: _____

Darren counted the number of young plants, K and L at various distances from their parent plants. The results are shown below.

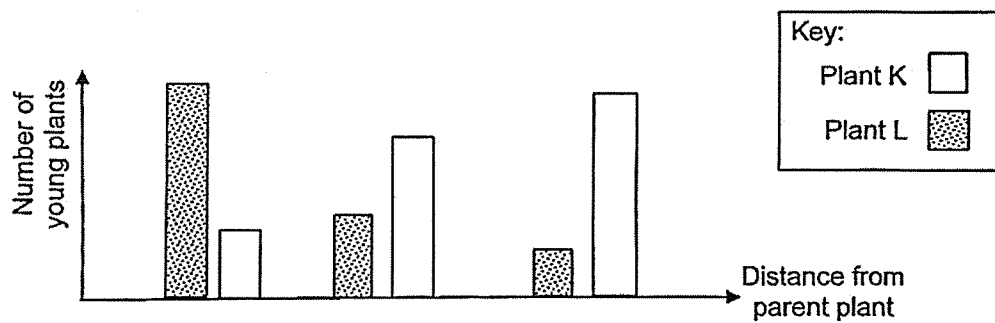

- (a) Which fruit, P or Q belongs to plant K? Explain why. [2]
- _____
- _____
- _____
- (b) Based on the diagrams above, state an advantage of Plant L's dispersal method over plant K's dispersal method. [1]
- _____
- _____

33. Two celery stalks were placed in red-coloured water as shown below. The colour of the leaves was then observed after three hours.

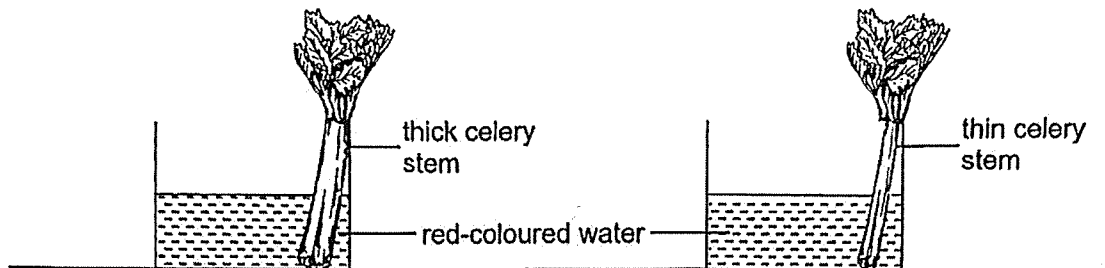

- (a) State the aim of the experiment. [1]

After three hours, the leaves of both stalks were stained red.

- (b) Describe how the red-coloured water could get to the leaves. [1]

The stem of the thick celery stalk was then cut. The cut section of the stem is shown below. Tube X turned red but tube Y did not.

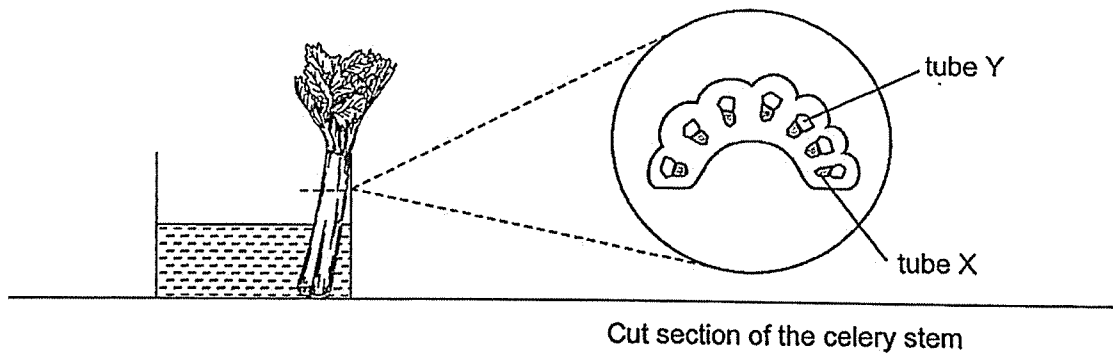

- (c) Identify tube Y and state its function. [1]

34. The graph below shows the changes in Mirabel's heart rate over time when she went running.

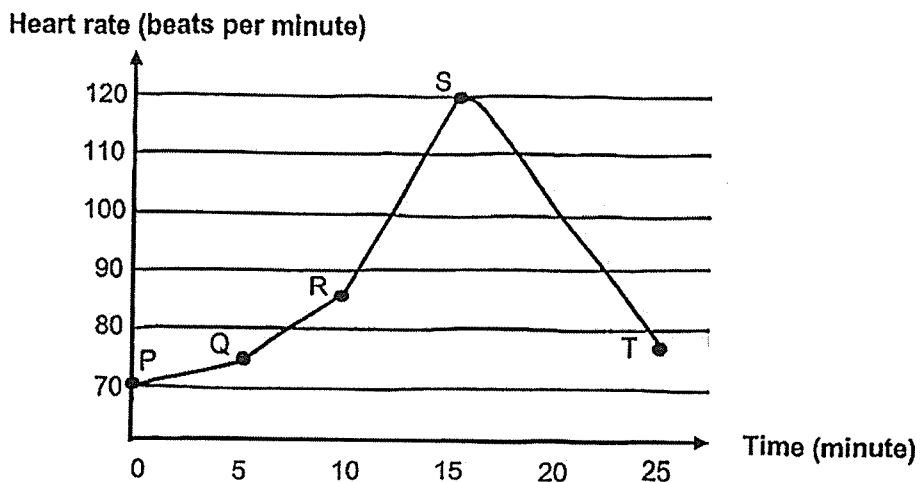

- (a) Based on the graph, describe the changes in her heart rate during the 15 minutes. [1]

- (b) (i) Suggest how Mirabel's activity changed after point S. [1]

- (ii) Explain how the change in her heart rate based on your answer in (i). [1]

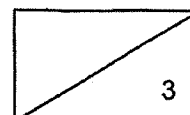

35. Andrew observed three cells, P, Q and R, under the microscope. He recorded his observations in the table below. A tick (✓) indicates the presence of the part of a cell.

Cell Part	Cell P	Cell Q	Cell R
Cell wall	✓		✓
Nucleus	✓	✓	✓
Chloroplast			✓
Cell membrane	✓	✓	✓

- (a) Based on the table, is cell R from the leaf or from the root of a plant? Give a reason for your answer. [1]

- (b) (i) State another common cell part between cells P, Q and R that is **not stated** in the table above. [1]

- (ii) Describe the function of the cell part in (b)(i). [1]

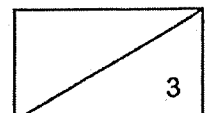

36. The graph below shows the amount of digested food in various parts of the digestive system after a girl had a meal.

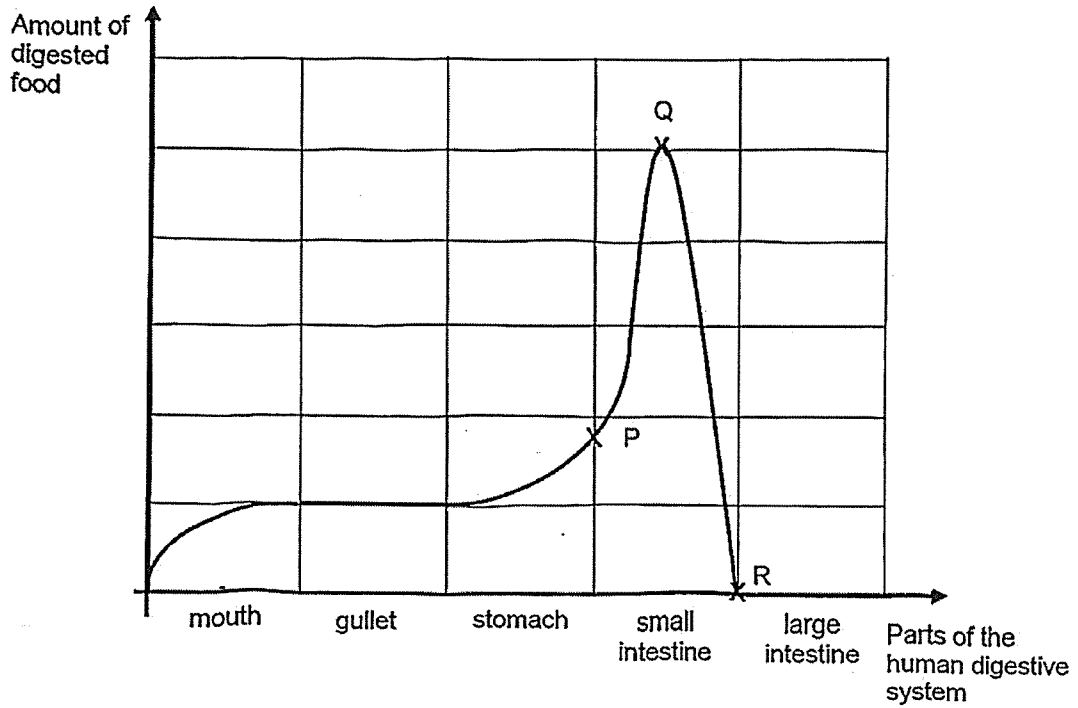

- (a) Which part(s) of the digestive system produce(s) digestive juices? [1]

- (b) Describe and explain the changes in the amount of digested food in the small intestine, between points P and R. [2]

- (i) From point P to point Q

- (ii) From point Q to point R

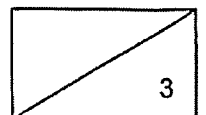

37. Charles had a toy as shown in the diagram below. The top pair of wings could be turned to wind up a rubber band in the centre.

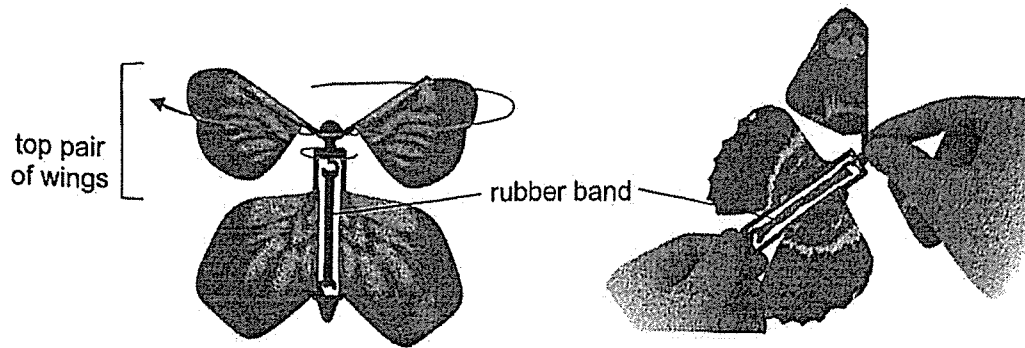

He turned the wings a few times before releasing the toy into the air at the starting point marked on the ground. He observed that the wings turned noisily and the toy moved for a short while before falling to the ground.

Charles then repeated what he did, increasing the number of times he turned the wings each time.

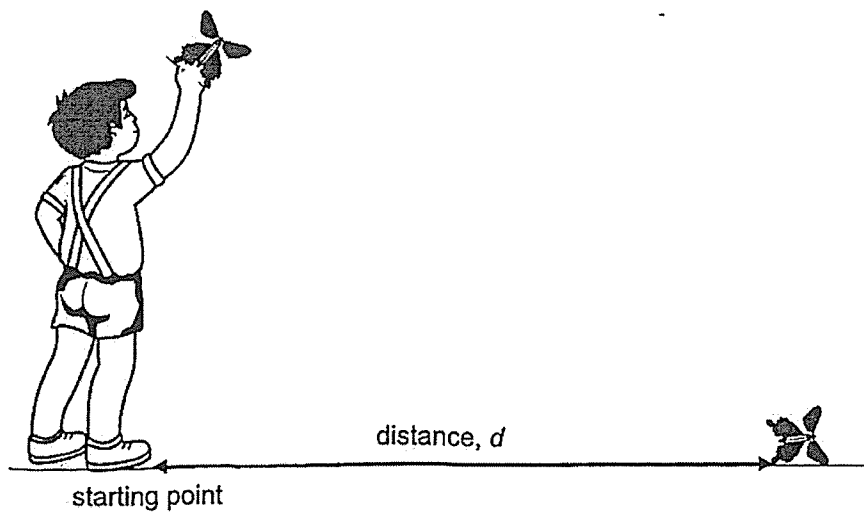

38. (a) What is a force?

[1]

Mabel set up an experiment. She glued the spring to the table as shown below. She then attached a steel block on the spring. The length of the compressed spring was 10cm.

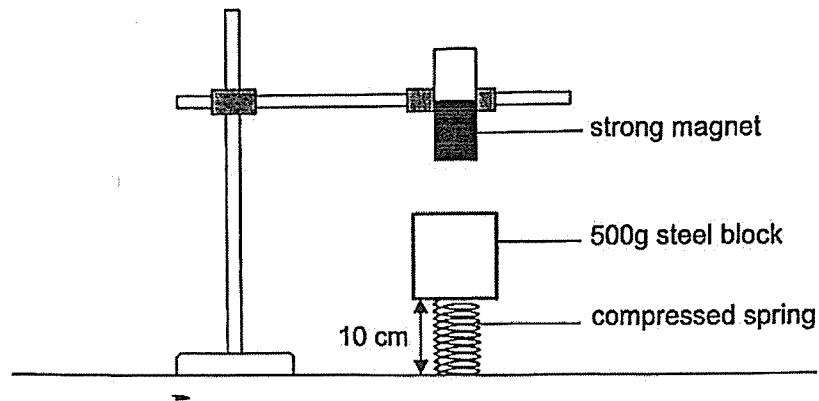

- (b) State the force(s) acting on the steel block.

[1]

Mabel then removed the 500g steel block and attached a 500g wooden block.

- (c) What would Mabel observe about the length of the spring? Explain her observation. [2]

Finally, she replaced the wooden block with a 500g object X. She observed that the length of the compressed spring was 6 cm.

- (d) Suggest what object X could be.

[1]

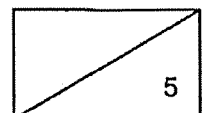

39. The diagram below shows a paper counting system that is made up of a light source, a light sensor and a datalogger. Paper P is placed at an equal distance between the light source and the light sensor. The light sensor measures the amount of light passing through the paper.

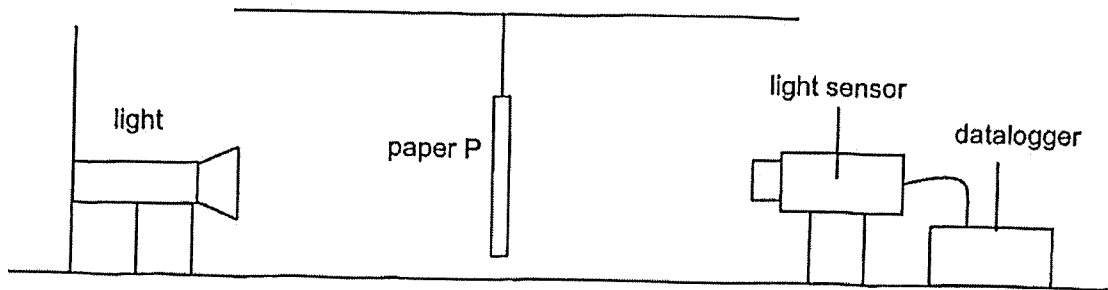

The graph below shows the number of sheets of paper P and the amount of light recorded by the light sensor and datalogger.

Amount of light detected (units)

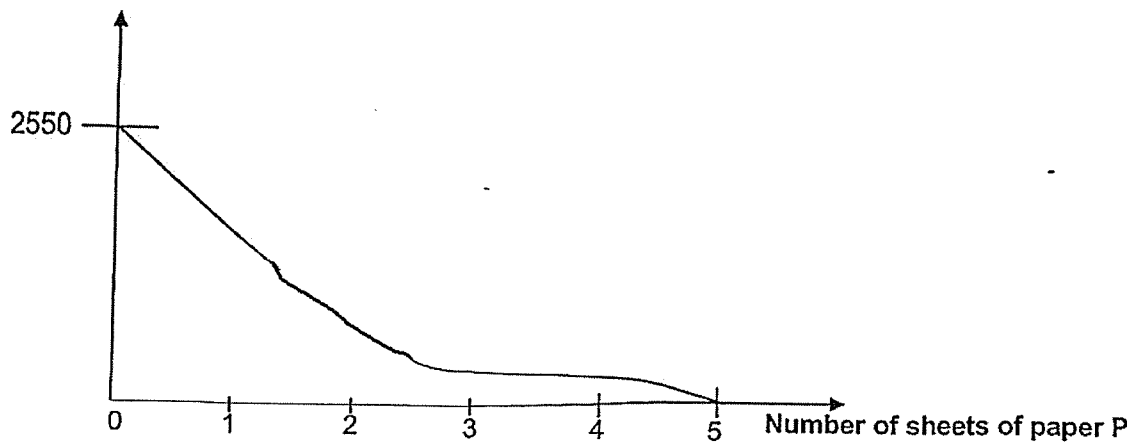

- (a) Based on the results above, state the maximum number of sheets Alexis should use to make a strong bag that still allows her to see the shapes of the items in the bag. [1]
-
- (b) Give a reason the amount of light decreases as the number of sheets increases. [1]
-
- (c) Suggest a way to ensure that the results are reliable. Explain your suggestion. [2]
-
-
-

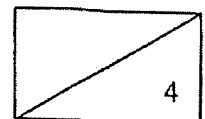

40. Lingling held the cup of hot drink and almost scalded her fingers. The stall holder offered her a cup sleeve to put around her cup as shown below. She noticed that the inner side of the cup sleeve was corrugated.

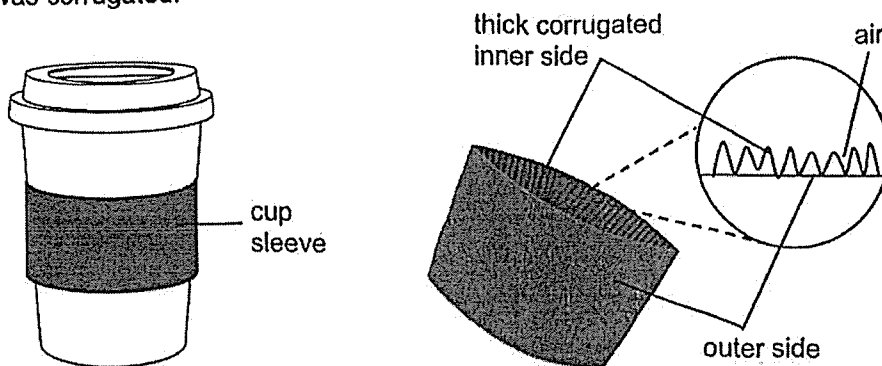

- (a) Explain how the corrugated inner side of the cup sleeve will prevent Lauren from scalding her fingers. [2]

When Lingling got home, she poured a cold drink into a double-walled cup to keep it cold for a long time. The double-walled cup has a layer of air between the two walls of the cup as shown below.

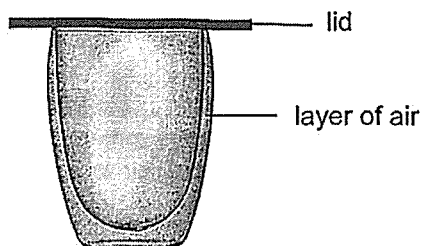

- (b) Explain how the double walled cup helps to keep her cold drink cold for as long as possible. [2]

~ END OF BOOKLET B ~

SCHOOL : NANYANG PRIMARY SCHOOL
LEVEL : PRIMARY 6
SUBJECT : SCIENCE
TERM : 2025 PRACTICE

Q1	Q2	Q3	Q4	Q5	Q6	Q7	Q8	Q9	Q10
3	2	2	4	3	4	1	1	3	3
Q11	Q12	Q13	Q14	Q15	Q16	Q17	Q18	Q19	Q20
2	1	3	2	4	1	2	2	3	4
Q21	Q22	Q23	Q24	Q25	Q26	Q27	Q28		
2	3	2	1	2	2	1	3		

29.(a)	Set the temperature at 20°C and the amount of water vapour in the air at 60 units. Under these conditions, the number of eggs hatched was the most
(b)	The young will feed on the leaves once they are hatched.
30.(a)	Organism P
(b)(i)	Organisms R and U
(ii)	Less T feeding on R. Population of R will increase. Less T for U to feed on. Population of U will decrease.
31.(a)	- warmer water vapour in the surrounding air - lost heat to the cooler surface of the box and condensed - water droplets further lost heat - and froze
(b)	- Thin layer of ice gained heat (from the surroundings) and melted to form water
32.(a)(i)	Fruit P: / splitting and wind Fruit Q: splitting.
(b)	Choice: Fruit P. Data: plant K has less young plants nearer to parent plants Explain: Fruit P disperses seed by splitting and wind and it has wing-like structure to disperse the seeds further from the parent plants.

(c)	It does not depend on external factors like wind to disperse the seeds.
33.(a)	To find out if the thickness of the celery stem affects the amount of water absorbed
(b)	Water-carrying tubes, transports the red-coloured water to all parts of the plant.
(c)	Tube Y is the food-carrying tube, it transports food made in the leaves to all parts of the plant.
34.(a)	Her heart rate increased.
(b)(i)	She slowed stopped running.
(b)(ii)	Her heart pumped blood slower. Heart pump less blood containing less oxygen and digested food
35.(a)	C: leaf cell D: it has chloroplasts E: for the leaves to trap light to make food
(b)(i)	Cytoplasm.
(b)(ii)	It is where cell activities take place.
36.(a)(i)	mouth, stomach, small intestine
(ii)	The amount of digested food increased as food was digested.
(iii)	The amount of digested food decreased as digested food was absorbed into the bloodstream.
37.(a)	rubber band
(b)	potential energy \rightarrow Kinetic energy + Heat/potential energy + Sound (must include)
(c)	– As the number of turns increases from 5 to 20, the distance travelled by the toy increases. – After 20 turns, as the number of turns increases, the distance travelled by the toy remains the same.
(d)	Release the toy from the same height
38.(a)	A force is a push or a pull.
(b)	Gravitational force/ gravity Elastic spring force/ elastic force/magnetic force
(c)	C: The spring would decrease in length/ shorter than 10cm.

	D: Wood is a non-magnetic material E: It will NOT be attracted to the strong magnet and compress the spring more.
(d)	Object X is a magnet
39.(a)	4
(b)	More light is blocked as more sheets of paper P is used.
(c)	Repeat the experiment at least 3 times and calculate the average. This allows us to check for consistency in the results.
40.(a)	It reduces the surface area in contact (with her fingers/ cup). Her fingers will gain heat slower from the hot cup.
(b)	Air is a poor conductor of heat Heat is conducted from the surroundings to the cold drinks slower

www.sgexam.com

www.sgexam.com