

Nan Hua Primary School
 P6 Science
 Timed Practice Paper (Term 2)

Name: _____
 TG: 6S _____
 Date: _____

Section A: Multiple Choice Questions [56 marks]

For each question from 1 to 28, four options are given. One of them is the correct answer.

Indicate your choice in this booklet and shade the correct oval (1, 2, 3 or 4) on the Optical Answer Sheet provided.

1. Glenda wanted to find out how a plant affects the amounts of gases in its surroundings at different times of a day. She placed the plant in a clear sealed container in a well-lit garden as shown below.

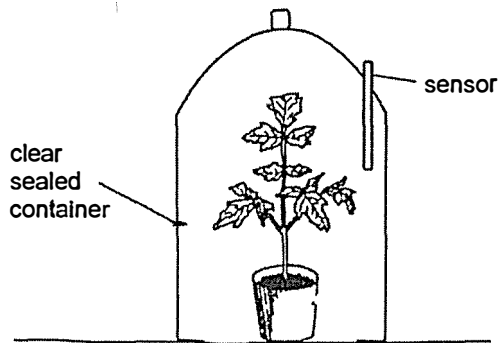

She recorded the amounts of two different gases, A and B, in the graph as shown below.

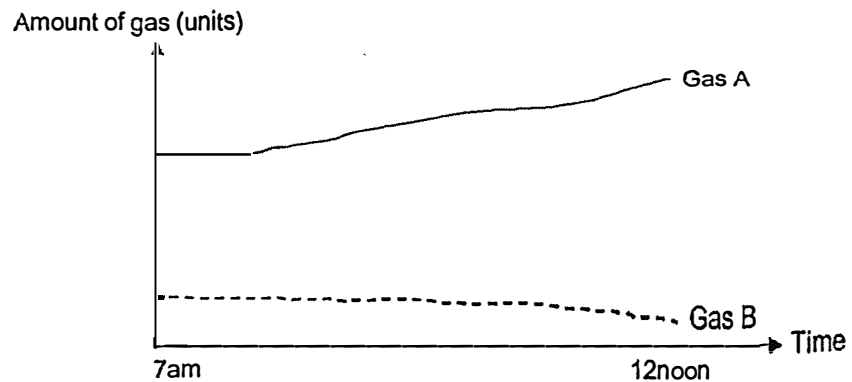

What could gases A and B most likely be?

	A	B
(1)	oxygen	nitrogen
(2)	oxvgen	carbon dioxide
(3)	carbon dioxide	oxvgen
(4)	carbon dioxide	nitrogen

2. Which of the following statements are true?

- A All living things depend directly on plants for food.
- B The Sun is the main source of energy for all living things.
- C Energy is transferred from the Sun to plants during photosynthesis.
- D Only water, oxygen and sunlight are needed for a plant to make food.

- (1) A and C only
- (3) B and C only

- (2) A and D only
- (4) B and D only

3. Zirui conducted an experiment in a dark room to find out how the amount of light affects the rate of photosynthesis. He used a device to count the number of bubbles produced by the water plant in three minutes.

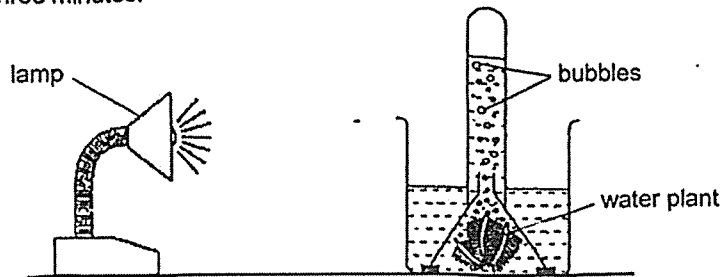

Then he added a sheet of paper between the lamp and the water plant and counted the number of bubbles produced. He repeated this step until a total of 6 sheets of paper were used.

Which of the following graphs correctly shows his most likely observations?

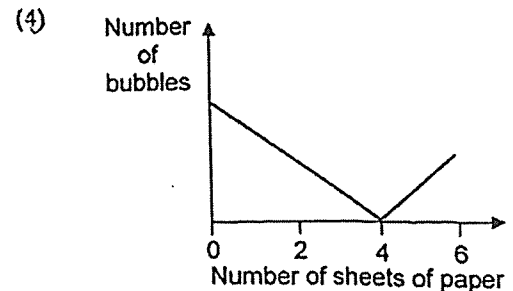
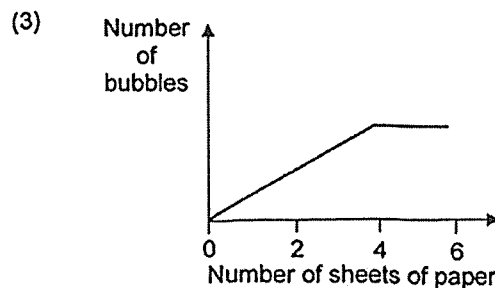
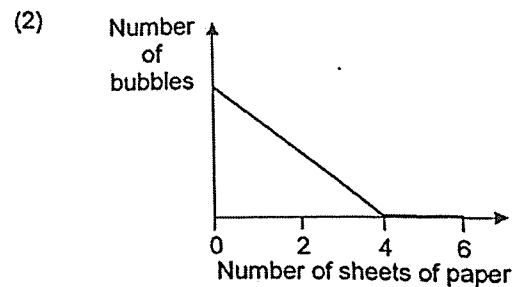
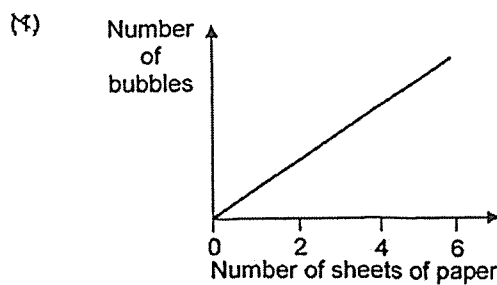

4. Diana counted the number of each type of organism she found in a garden and recorded her results in the graph below.

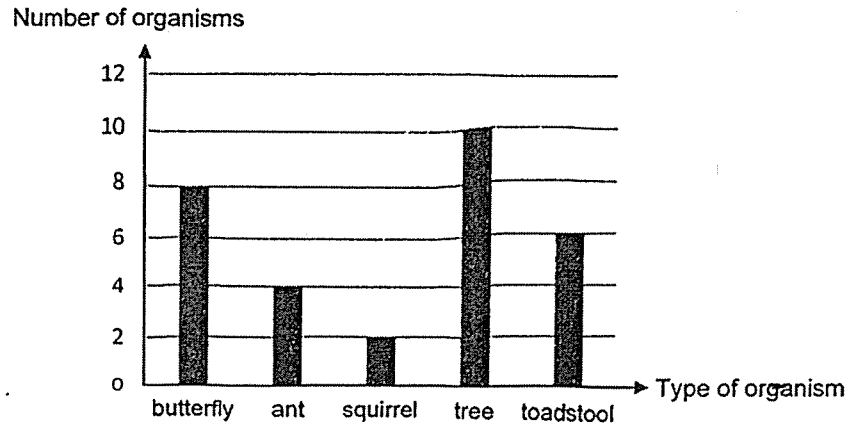

Which one of the following statements about this garden community is correct?

- (1) There are 5 organisms in this garden.
 - (2) There are at least 4 populations of ants.
 - (3) This garden community consists only of 4 types of animals.
 - (4) The trees are the main source of food for the animals in this garden community.
5. The diagram below shows a pond and the organisms living in it. The organisms depend on each other for survival.

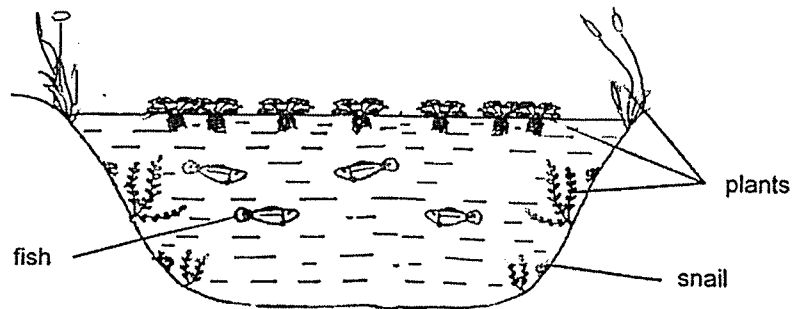

Which one of the following statements correctly describes how the organisms benefit from each other?

- (1) Fish provide oxygen for the plants and plants provide food for the fish.
- (2) Snails provide oxygen for the plants and plants provide shelter for the snails.
- (3) Fish provide carbon dioxide for the plants and plants provide food for the fish.
- (4) Snails provide carbon dioxide for the plants and plants provide droppings for the snails.

6. Jie Ying observed that mangrove plants are often found growing in soil that holds a lot of water. She tested four types of soil, A, B, C and D, by using the set-up as shown below. She poured 50 ml of water into soil A. She then measured the amount of water collected in the measuring cylinder after 30 minutes.

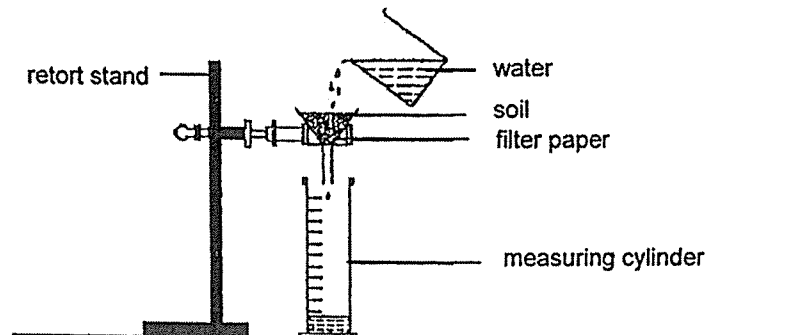

Jie Ying repeated the experiment with the same amount of soils B, C and D. She recorded the results in the table below.

Type of soil	Amount of water collected (ml)
A	38
B	20
C	24
D	18

Based on the results above, which soil is the most suitable for growing mangrove plants?

- (1) A
- (2) B
- (3) C
- (4) D

7. Hugo found the following organisms in a forest.



Which of the above organism(s) is/are decomposer(s)?

- (1) fungi only
- (2) fungi and fern only
- (3) ant and earthworm only
- (4) earthworm and fern only

8. Study the food web below.

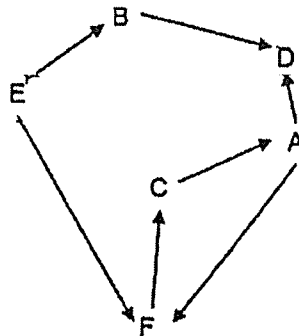

Which of the following about living things A to F in the food web above is correct?

	Food producer	Predator only	Prey only	Predator and prey
(1)	D	A and C	E	B and F
(2)	D	F	B and C	A and E
(3)	E	B and C	D	A and F
(4)	E	D	B	A, C and F

9. The food chain below shows how some organisms in a community depend on one another for survival.



A large number of organism W was introduced to this habitat.

If organism W only fed on the birds, which one of the following graphs below shows the effect of this on the populations of the other organisms?

(1)

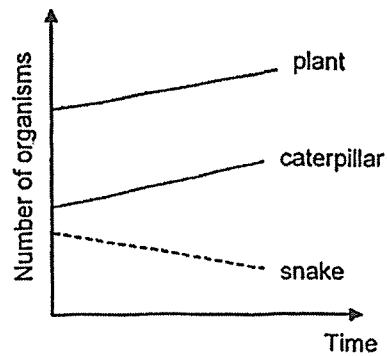

(2)

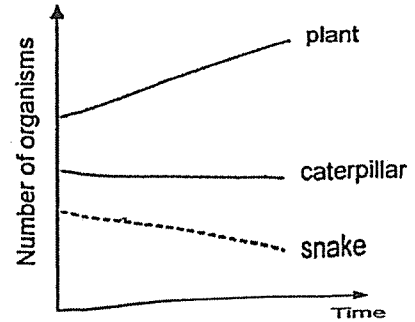

(3)

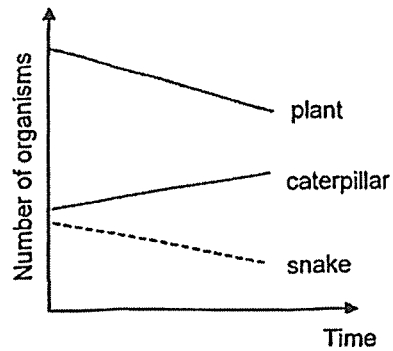



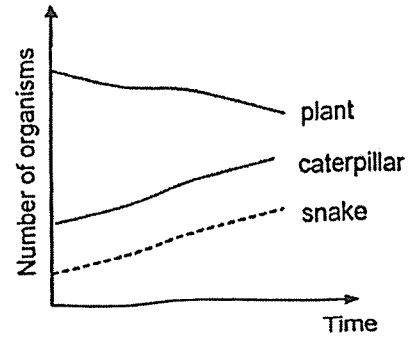

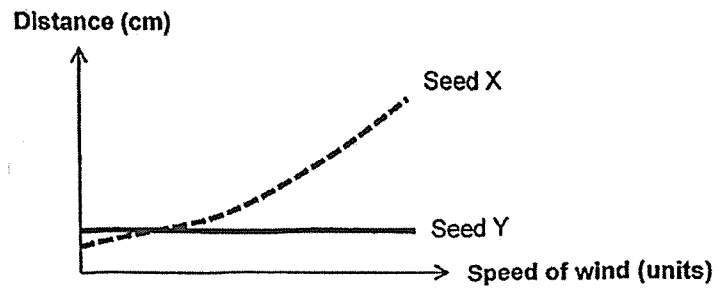

(4)



12. X and Y are two different types of seeds with different methods of dispersal. The graph below shows how the speed of wind affects the average distance the seeds are dispersed.

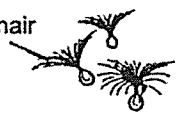

Which one of the following shows the most likely appearance of seeds X and Y?

	Seed X	Seed Y
(1)	hair 	pod 
(2)	pod 	fibrous husk 
(3)	fibrous husk 	wing-like structure 
(4)	wing-like structure 	hair 

13. Aishah removed the food-carrying tubes of a plant at position Z as shown in the diagram below. The plant was watered daily.

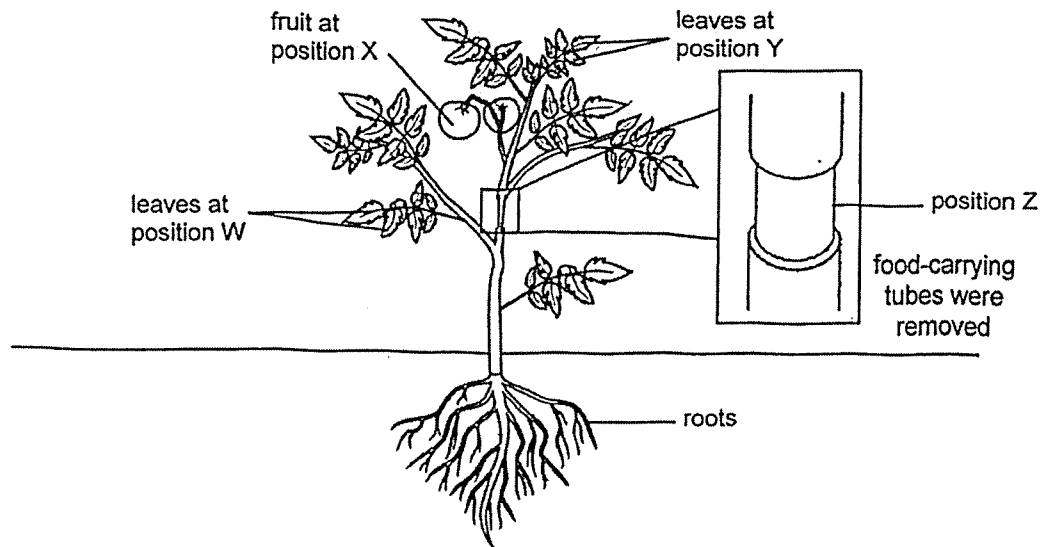

Which of the following are possible observations of the plant after a few weeks?

- A The fruit at position X grew bigger.
- B The leaves at position W withered.
- C The leaves at position Y remained green.

- (1) A and B only
- (2) A and C only
- (3) B and C only
- (4) A, B and C

14. Which of the following shows the correct comparison between inhaled air and exhaled air?

- (1) There is less oxygen in exhaled air than inhaled air.
- (2) There is more oxygen in exhaled air than inhaled air.
- (3) There is less carbon dioxide in exhaled air than inhaled air.
- (4) There is the same amount of carbon dioxide in exhaled air and inhaled air.

15. The diagram below shows the human digestive system.

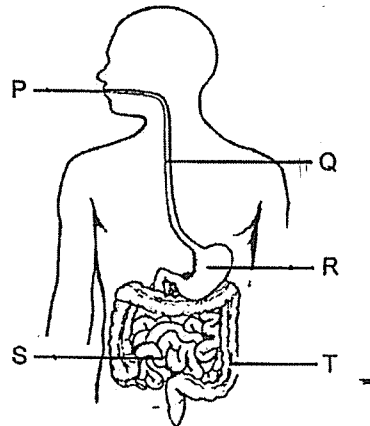

Which of the following correctly identifies the parts where digestion of food takes place?

- (1) P, Q and S only
 - (2) P, R and S only
 - (3) P, R and T only
 - (4) R, S and T only
16. Ruoling wanted to classify the four plants as shown below.



bird's nest fern



coconut tree



sunflower plant

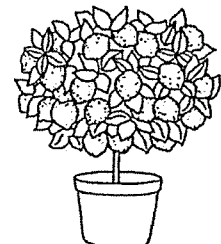

lime plant

Which one of the following questions can be used to classify the plants above into two groups?

- (1) Can it make its own food?
- (2) Does it reproduce by seeds?
- (3) Does it need air, food and water?
- (4) Can it respond to changes in its surroundings?

17. Substance X is a solid at 20°C and a gas at 180°C.

Which one of the following could be possible?

	Melting Point of X (°C)	Boiling Point of X (°C)
(1)	18	200
(2)	18	170
(3)	25	200
(4)	25	170

18. Geetha heated a beaker of ice for a length of time before removing the heat source. She recorded the changes in its temperature as shown in the graph below.

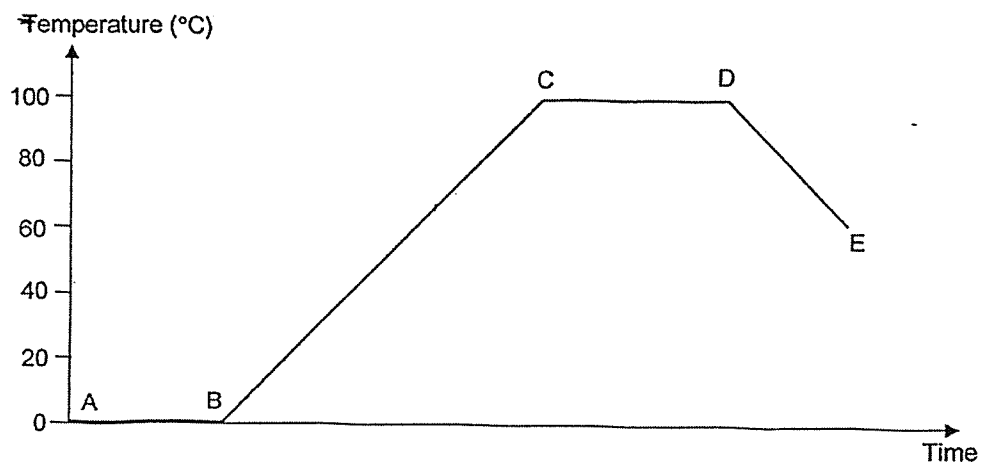

Which part(s) of the graph show(s) ice/water gaining heat?

- (1) BC only
 (2) AB and CD only
 (3) AB, BC and CD only
 (4) AB, BC, CD and DE
19. Which of the following does **not** involve energy conversion?

- (1) Typing on the computer.
 (2) Keeping a lit candle burning.
 (3) Capturing light in solar panels.
 (4) Leaving a cup of hot water to cool.

20. The diagram below shows a cart at the starting position of three tracks, Q, R and S.

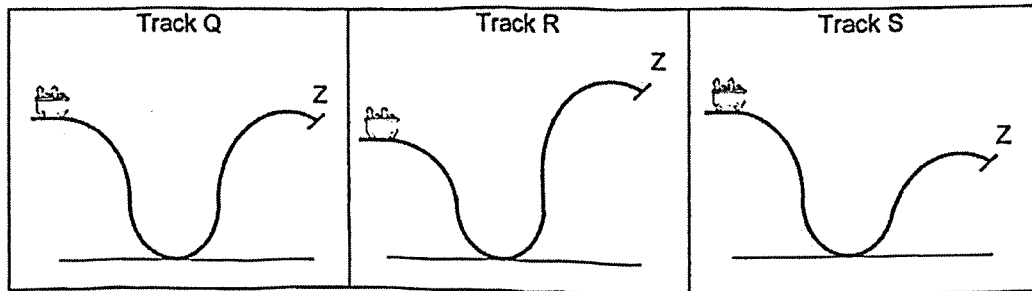

On which track(s) will the cart be able to reach point Z?

- (1) Q only
 (2) S only
 (3) Q and S only
 (4) Q, R and S

21. Mdm Sarina used an electric kettle to boil some water as shown in the diagram below. When the water boiled, she heard a whistling sound from the kettle.



Which of the following shows the correct energy changes that took place at different parts of the set-up?

	Electrical wire		Heating coil		Steam rising		Whistling kettle
(1)	heat energy	→	electrical energy	→	potential energy	→	sound energy
(2)	heat energy		electrical energy	→	kinetic energy	→	potential energy
(3)	electrical energy		heat energy	→	potential energy	→	potential energy
(4)	electrical energy	→	heat energy	→	kinetic energy	→	sound energy

22. When constructing buildings, concrete blocks have to be pushed into the ground by heavy weights as shown in the diagram below.

The weight is lifted up by a machine and then released to hit the concrete block.

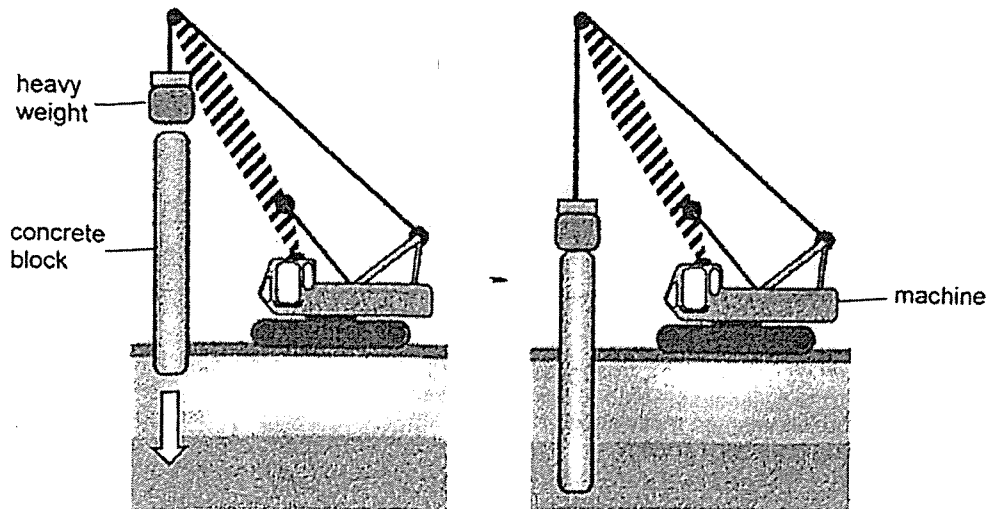

Which of the following would enable the weight to push the block deeper into the ground?

- A Use a weight of greater mass.
- B Apply oil on the bottom of the weight.
- C Raise the weight to a greater height before release.
- D Move the weight closer to the concrete block before release

- (1) A and C only
- (3) B and C only

- (2) A and D only
- (4) B and D only

23. Louisa conducted an experiment on three springs of equal lengths at first, A, B and C. She placed identical 100g masses on all three springs. Her observations are as shown below.

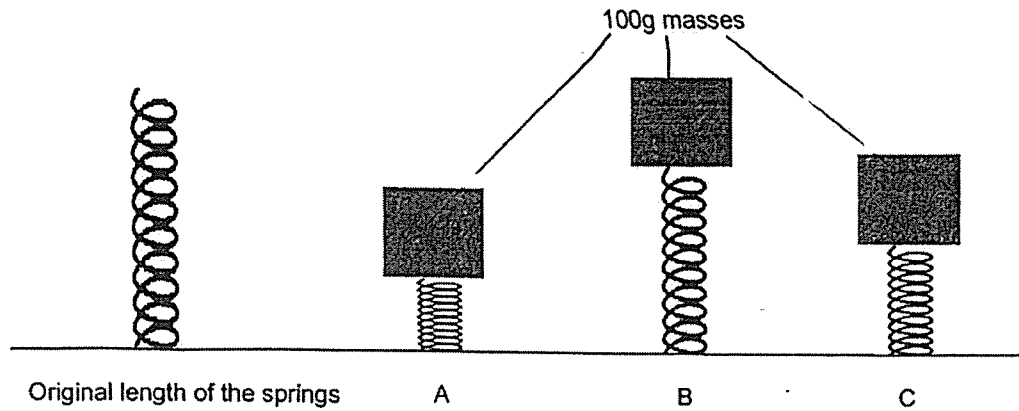

Which of the following correctly shows how the three springs will be stretched with identical masses hung from each spring?

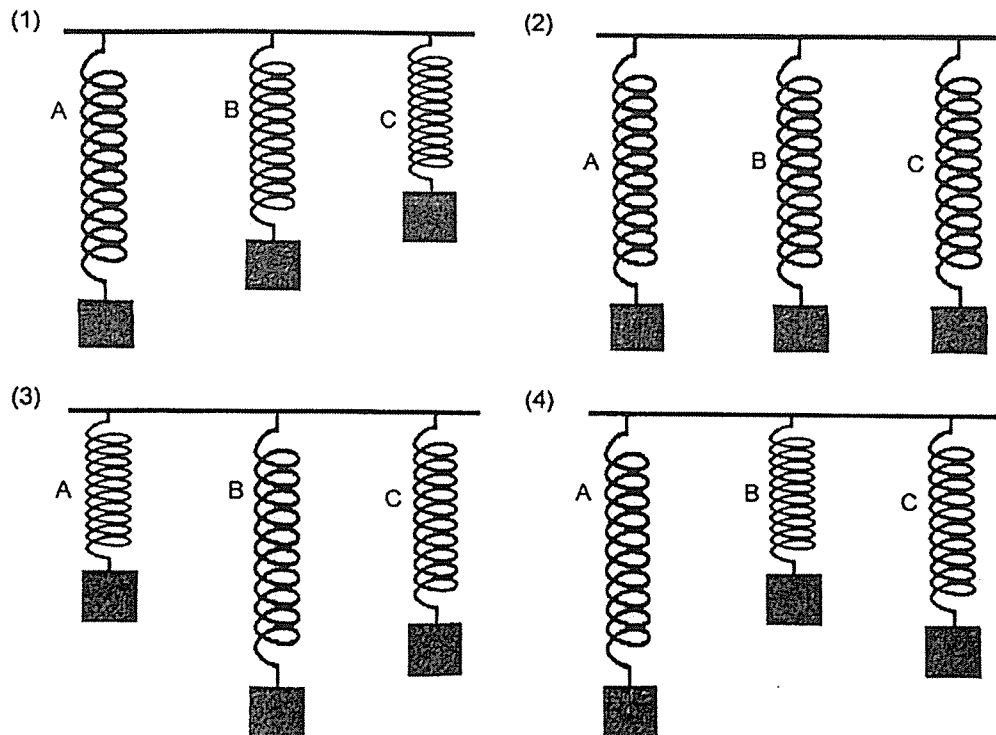

24. The diagram below shows Alan throwing a ball into the air.

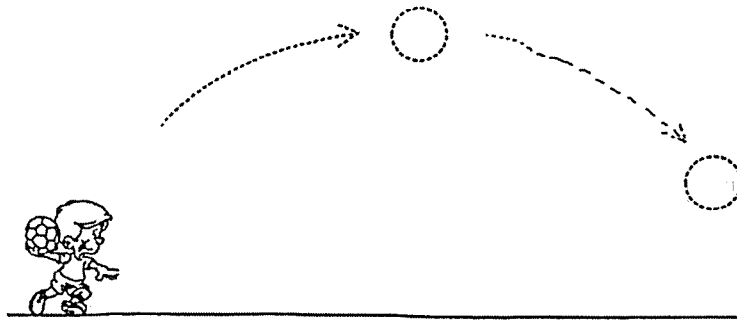

Which of the following describes the effect of the force Alan exerted at the start?

- (1) The force changed the shape of the ball.
- (2) The force caused the ball to start moving.
- (3) The force caused the ball to stop moving.
- (4) The force decreased the speed of the ball.

25. Peter stood in front of a door.

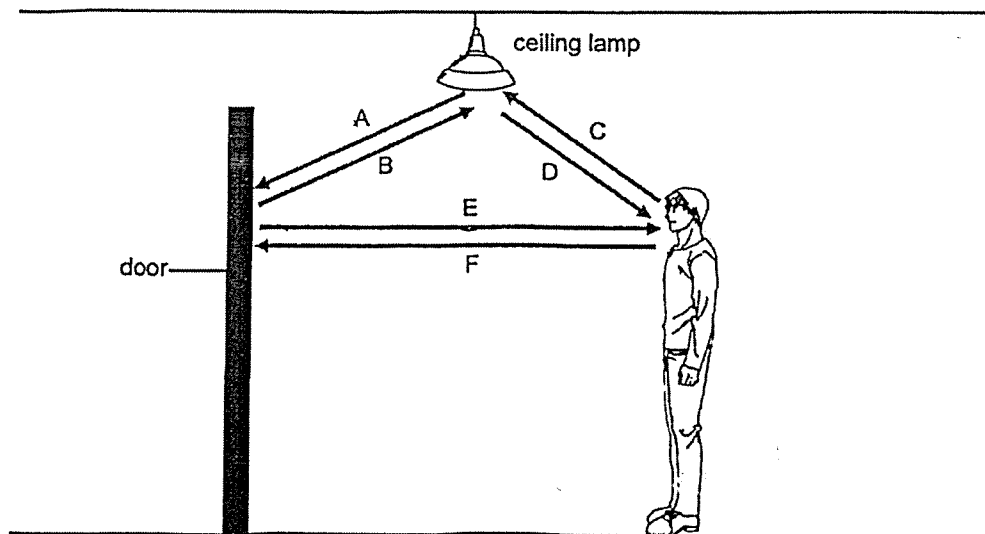

Which of the arrows show the correct direction of light rays that will enable Peter to see the door?

- | | |
|---------------------|---------------------|
| (1) A and E only | (2) B and F only |
| (3) A, C and E only | (4) B, D and F only |

26. Sheena cut out some shapes from a piece of cardboard as shown below. The shapes had the same height and width.



She then hung the shapes in a straight line at positions D, E and F as shown in the diagram below.

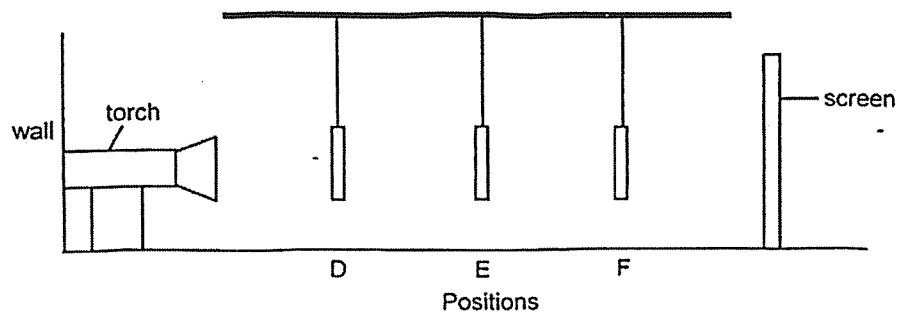

The following shadow was cast on the screen.

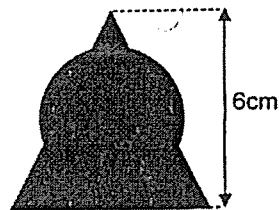

Based on the shadow formed, which of the following shows the correct positions of the shapes in the set-up above?

	Position D	Position E	Position F
(1)			
(2)			
(3)			
(4)			

27. Equal volumes of hot water at 80°C were poured into four identical containers of different materials.
Which of the following containers will most likely contain water at the lowest temperature after two hours?

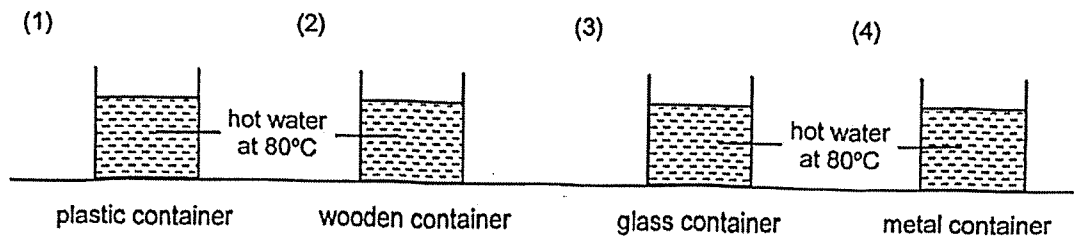

28. Two similar-sized pots, R and S, were placed on similar-sized stoves as shown below. 800ml of water was poured into pot R while 600ml of water was poured into pot S. The stoves were turned on at the same time.

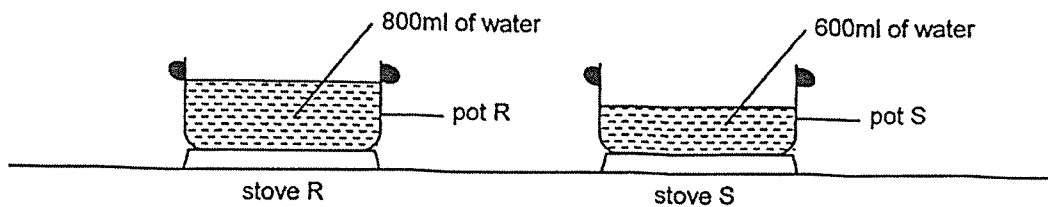

The water in both pots took the same amount of time to reach boiling point.
Which of the following could have resulted in this observation?

- A Stove R gave out more heat than stove S.
B Pot R was a better conductor of heat than pot S.
C The water in pot R had more heat than the water in pot S at the start.
D The water in pot S was at a higher temperature before the stoves were turned on.

- (1) A and D only (2) C and D only
(3) A, B and C only (4) B, C and D only

~ END OF BOOKLET A ~

Nan Hua Primary School
 P6 Science
 Timed Practice Paper (Term 2)

Name: _____
 TG: 6S____
 Date: _____

Section B: Open-Ended Questions [44 marks]

Write your answers to questions 29 to 40 in the spaces provided.

29. The diagram below shows organism K. The young of organism K feeds on leaves.



Ayu conducted an experiment to find out the effects of the surrounding temperature and the amount of water vapour in the air on the number of eggs hatched by organism K over a period of time.

The graph below shows the results of her experiment.

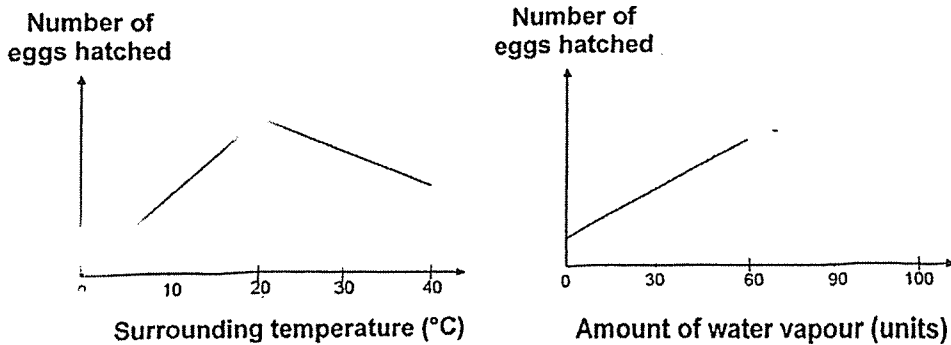

(a) Based on the results above, suggest how Ayu could ensure the most number of eggs hatched over a period of time? Explain your answer. [2]

Organism K lays its eggs, which hatch into larvae, on the leaves of plants. The larvae grow in size after some time.

(b) Explain how laying its eggs on leaves increases the chances of survival of organism K's young. [1]

30. Organisms A, B, C, D and E form a food web in their habitat as shown below.

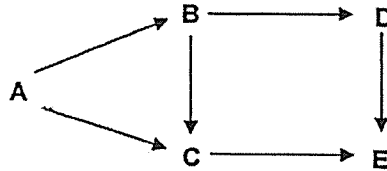

(a) How many food chains are there in the food web above? [1]

(b) State a physical condition in the above habitat that is likely to affect the population of organism A. [1]

(c) What would happen to the population of organism B if all the organism E are removed from the habitat? Explain your answer. [2]

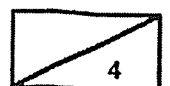

31. Carl waited outside a store for his parents. He noticed that there were water droplets on the window and he used his finger to write a message on it.

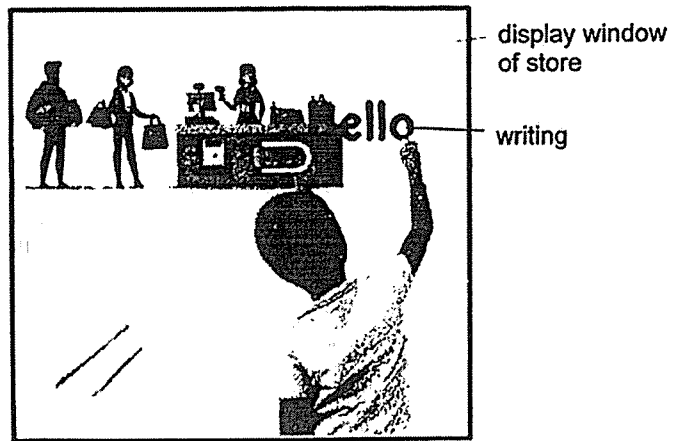

- (a) Explain clearly why there were small droplets of water on the store window. [2]

- (b) Before leaving, Carl noticed that his writing had disappeared. Explain why. [1]

32. The diagram below shows young plant G.

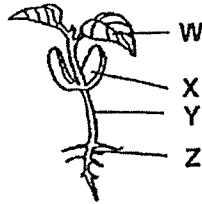

The graph below shows the changes in the mass of one part of young plant G as it develops and grows.

Mass (g)

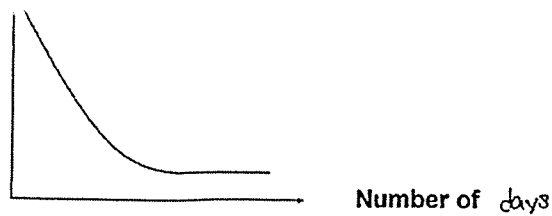

(a) Which one of the plant parts, W, X, Y or Z, does the above graph most likely represent? Explain your answer. [2]

Kaiting found the following organisms growing in a park.

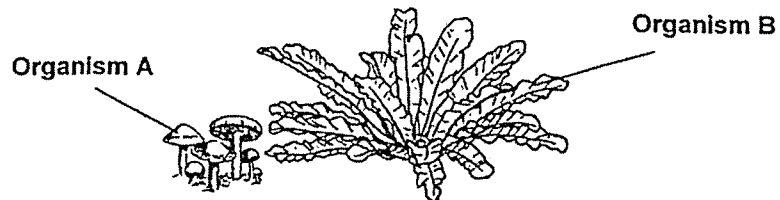

(b) Based on how they reproduce, state a similarity between organisms A and B. [1]

(c) Based on how they obtain food, state a difference between organisms A and B. [1]

Page

33. Two celery stalks were placed in red-coloured water as shown below. The colour of the leaves was then observed after three hours.

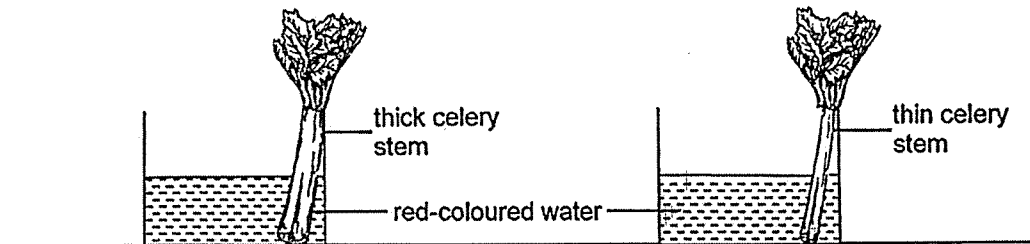

- (a) State the aim of the experiment. [1]

After three hours, the leaves of both stalks were stained red.

- (b) Explain how the red-coloured water could get to the leaves. [1]

The stem of the thick celery stalk was then cut. The cut section of the stem is shown below. Tube X turned red but tube Y did not.

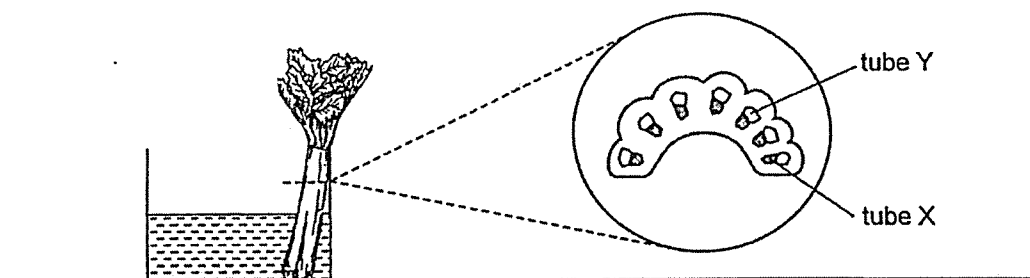

Cut section of the celery stem

- (c) Identify tube Y and state its function. [1]

34. The graph below shows the changes in Mirabel's heart rate over time when she went running.

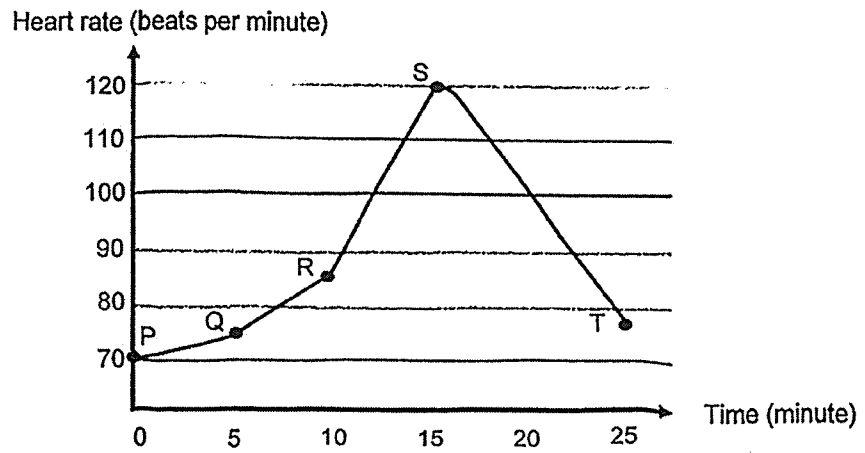

- (a) Based on the graph, describe the changes in her heart rate during the 25 minutes. [1]

- (b) Based on the graph, explain how Mirabel's heart rate changed after point S. [2]

35. The diagram below shows a plant cell.

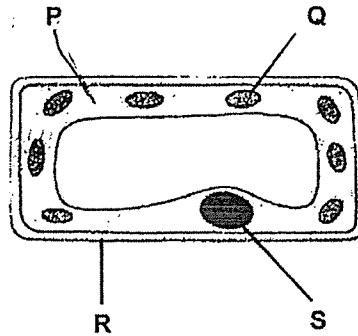

(a) (i) Which part(s), P, Q, R and/or S, is/are present in all plant cells but not in animal cells? [1]

(ii) State a function of the part(s) that you have stated in (i). [1]

(b) Is the cell shown above from the leaf or from the root of a plant? Explain your answer. [1]

36. (a) State two functions of the small intestine. [2]

(i) _____

(ii) _____

The graph below shows the amount of undigested food entering and leaving two parts of the human digestive system after a meal.

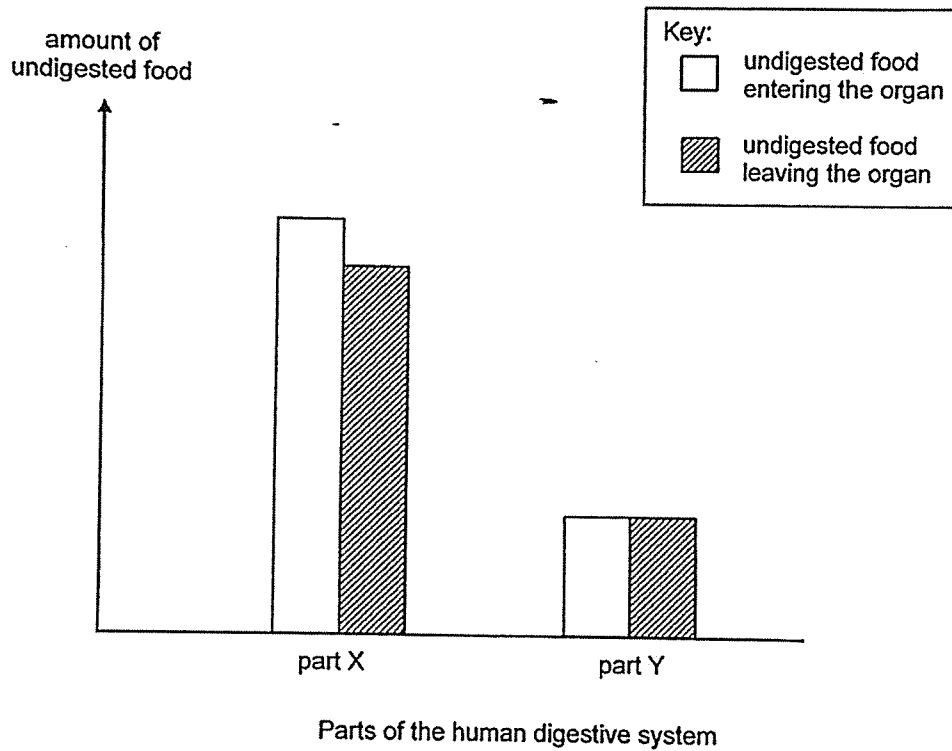

(b) Based on the graph above, which part, X or Y, represents the large intestine? Explain your answer. [1]

37. Chong Han had a toy as shown in the diagram below. The top pair of wings could be turned to wind up a rubber band in the centre.

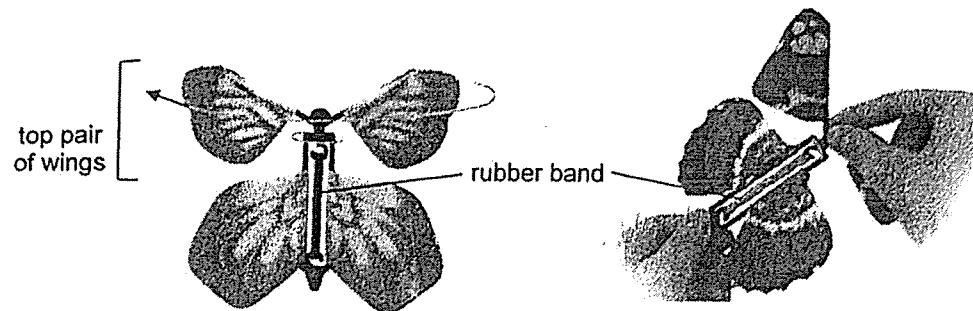

He turned the wings a few times before releasing the toy into the air at the starting point marked on the ground. He observed that the wings turned noisily and the toy moved for a short while before falling to the ground.

Chong Han then repeated what he did, increasing the number of times he turned the wings each time.

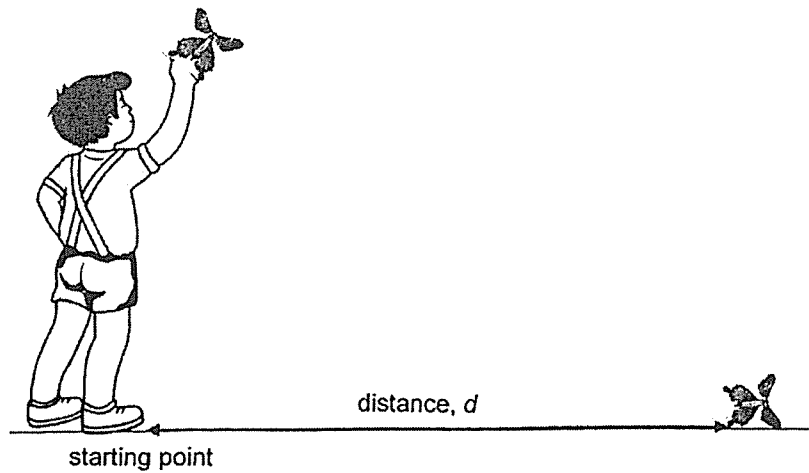

He measured the distance the toy travelled and recorded his results in the table below.

Number of turns	5	10	15	20	25	30
Distance, <i>d</i>, travelled by the toy (cm)	25.3	41.7	58.1	75.0	74.8	75.2

- (a) Which part of the toy provided the source of energy that made it work? [1]

- (b) State the forms of energy for the energy conversion in the toy when it was released. [1]

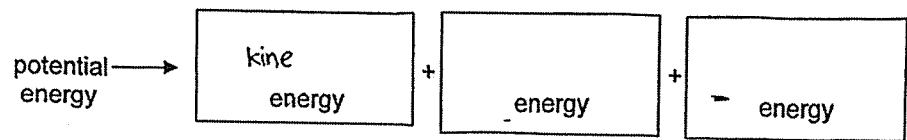

(toy before release)

(toy after release)

- (c) Based on the results shown above, what was the relationship between the distance moved by the toy and the number of turns made to the wings? [2]

- (d) Without making changes to the toy, suggest one way that Chong Han could make his results more accurate. [1]

38. (a) State how shadows are formed. [1]

Edward is preparing for a puppet show. He was given four stiff materials, P, Q, R and S, to make his puppets. He wanted to find out how much light could pass through the materials and prepared the set-up below.

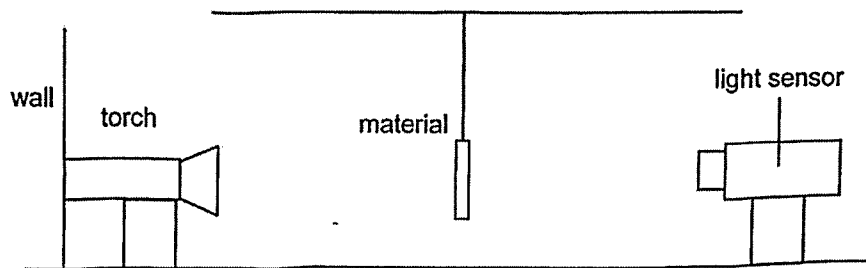

He placed each material between the torch and the light sensor and recorded the amount of light detected by the sensor. The table below shows his results.

Material	Amount of light detected (units)
P	50
Q	300
R	250
S	150

He wanted to make puppets that cast dark shadows on the screen.

(b) Based on the table above, which material should he choose to make his puppets so that they will cast the darkest shadows on the screen? Explain your answer. [2]

After making his puppets, Edward observed that the size of the shadow changed as he moved the puppet such that it is at different distances from the light source.

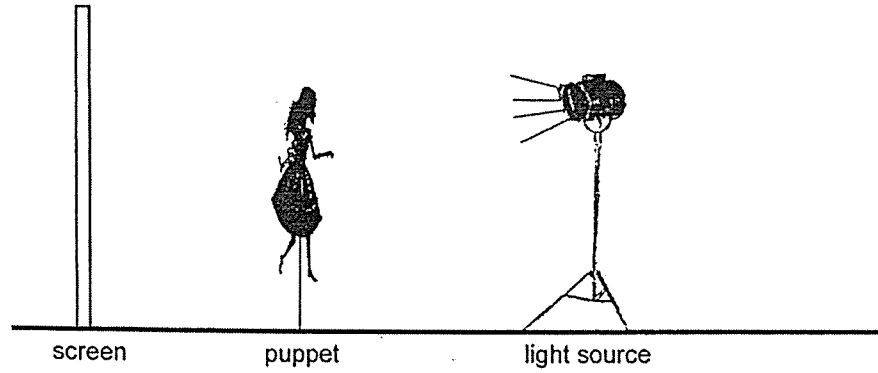

The screen is fixed to the ground.

- (c) What can Edward do to increase the size of the shadow cast on the screen by the puppet? [1]

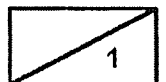

39. (a) What is a force? [1]

Mabel set up an experiment. She glued the spring to the table as shown below. She then attached a copper block on the spring. The length of the compressed spring was 10cm.

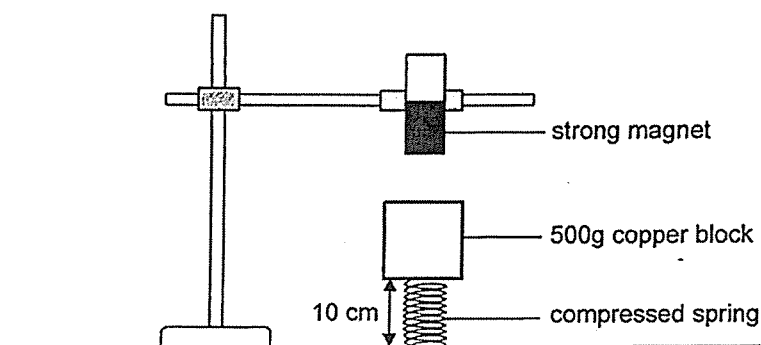

- (b) State the force(s) acting on the copper block. [1]

Mabel then removed the 500g copper block and attached a 500g iron block.

- (c) What would Mabel observe about the length of the spring? Explain her observation. [2]

Finally, she replaced the iron block with a 500g magnet. She observed that the length of the spring was less than 10cm.

- (d) Explain her observation. [1]

40. Lauren bought a hot drink which was served in a cup as shown below.

Lauren held the cup and almost scalded her fingers. The stall holder offered her a cup sleeve to put around her cup as shown below. She noticed that the inner side of the cup sleeve was corrugated.

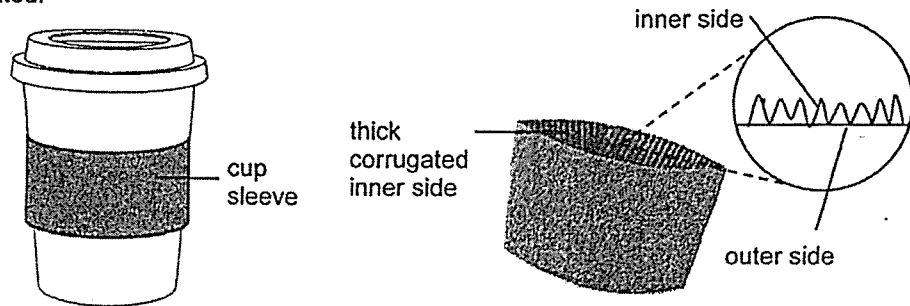

(a) Explain how the corrugated inner side of the cup sleeve will prevent Lauren from scalding her fingers. [2]

When Lauren got home, she poured a cold drink into a double-walled cup to keep it cold for a long time. The double-walled cup has a layer of air between the two walls of the cup as shown below.

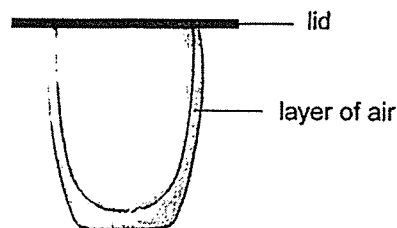

(b) Explain how the double walled cup helps to keep her cold drink cold for as long as possible. [2]

END OF BOOKLET B

SCHOOL : NAN HUA PRIMARY SCHOOL
LEVEL : PRIMARY 6
SUBJECT : SCIENCE
TERM : 2025 PRACTICE 2

Q1	Q2	Q3	Q4	Q5	Q6	Q7	Q8	Q9	Q10
2	3	2	4	3	4	1	4	3	1
Q11	Q12	Q13	Q14	Q15	Q16	Q17	Q18	Q19	Q20
3	1	2	1	2	2	4	3	4	2
Q21	Q22	Q23	Q24	Q25	Q26	Q27	Q28		
4	1	4	2	1	2	4	3		

29a	<p>[Choice] Ayu could set the temperature to 20°C and water vapour to 60 units or more,</p> <p>[Evidence from the graph] as the graph shows most eggs hatched under these two conditions.</p>
29b	The larvae will feed on the leaves once they are hatched from the eggs.
30a	3
30b	<p>Sunlight/ water/ oxygen/ carbon dioxide</p> <p>* Any one of the factors that affect the plant (photosynthesis and respiration) since Organism A is a plant.</p>
30c	<p>[Choice] Population of B will decrease.</p> <p>[Evidence from the food chain] Organism C and D will have no predators when all organism E are removed, causing the population of C and D to increase.</p> <p>[Link] Hence, there will be more C and D feeding on B.</p>
31a	<p>[Source of water vapour] Warmer water vapour outside the store</p> <p>[Condensation process] came into contact with the cooler surface of the window, lost heat and condensed into water droplets on the window.</p>

31b	Water droplets had formed again in the space where Carl wrote:
32a	[Choice] Part X. [Evidence from the graph] The graph shows the mass decreased as the number of days increases. [Concept] Part X which is the seed leaves stored food and was used by the young plant.
32b	Both reproduced by spores.
32c	A feeds on living things, dead or alive. B makes its own food.
33a	To find out how the thickness of the celery stem affects the colour of the leaves.
33b	Water-carrying tubes transport the red-coloured water to the leaves.
33c	Food-carrying tubes transport the food made by the leaves to all parts of the plant.
34a	In the first 15 minutes, her heart rate increased. After 15 minutes, her heart rate decreased.
34b	[Evidence from the graph] The graph shows her heart rate decreased after point S. [Concept] Her heart pumped blood slower to transport less oxygen and digested food to all parts of the body.
35a	(i) Part R (ii) It gives the cell its shape.
35b	[Choice] Leaf. [Evidence from the diagram] It has chloroplasts (part Q) [Concept] for the leaves to trap light to make food.

P6 Science Time-practice Answers

36a	(i) It digests food. (ii) It absorbs digested food into the blood.
36b	[Choice] Part Y. [Evidence from the diagram] The amount of undigested food entering and leaving part Y is the same. [Concept] As there is no digestion in the large intestine.
37a	Rubber band
37b	Kinetic energy + heat energy + sound energy
37c	As the number of turns increased from 5 to 20, the distance travelled by the toy increased. After 20 turns, as the number of turns increased, the distance travelled by the toy remained the same.
37d	Release the toy from the same height.
38a	Shadows are formed when light is blocked by an object.
38b	[Choice] Material P. [Evidence from the table] The least amount of light was detected. [Concept] This shows that P blocked the most light. [Link] So, the puppets will cast the darkest shadow.
38c	Move the puppet closer to the light source.

P6 Science Time-practice Answers

39a	A force is a push or a pull.
39b	Gravitational force and elastic spring force.
39c	The spring would increase in length. Iron is a magnetic material, and it would be attracted to the strong magnet.
39d	The like poles of the magnets were facing each other so they repelled.
40a	<p>[Evidence from the diagram] The corrugated inner side of the cup sleeve reduces the exposed surface area in contact with the hot cup.</p> <p>[Concept] Hence, the cup sleeve will gain less heat from the hot cup,</p> <p>[Link] and Lauren's fingers will gain less heat from the cup sleeve, preventing her from scalding her fingers.</p>
40b	<p>[Evidence from the diagram] There is a layer of air between the two walls of the cup.</p> <p>[Concept] Since air is a poor conductor of heat, it will conduct heat slower from the warmer surroundings to the cold drink.</p> <p>[Link] Hence, the cold drink can be kept cold for as long as possible.</p>